

Pneumatic-Type Non-Contact Gripper for Laparoscopic Surgery and Optimization of Test Parameters for Maximum Air Speed

Şenol ERTÜRK

Abstract: During Laparoscopic surgeries, grippers are used to grasp and handle organs. Grasping joints of grippers have various toothed profiles to prevent organs from slipping. To prevent slipping, sufficient clamping force should be applied to grippers. Organ tissues may get stuck between joints and damaged. In this study, special-designed and pneumatic-type non-contact grippers for Laparoscopic surgeries relying on Bernoulli's principle were produced and tested for performance in terms of the maximum air speed they can reach under specific conditions. Taguchi method was used for experimental design (with Taguchi L_{25} orthogonal sequence) and optimization. As parameters, 5 gripper types, 5 air pressures (3-6,5 bar), 5 flow rates (2-2,8 m³/h) were chosen. Results were evaluated with signal-to-noise ratio (S/N), analysis of variance and three-dimensional graphics. A 3rd-order polynomial regression model was used for air speed, and mathematical equation was obtained. The optimum combination was of 6 bar and 2,8 m³/h flow rate. Taguchi method results with verification tests were less than the admissible 20% error value. Reliability of optimization was tested by verification experiments performed within the specified confidence interval. The results are important in terms of developing grippers working without clamping force in laparoscopic surgeries and preventing gripper-induced tissue damage.

Keywords: Laparoscopic gripper; non-contact gripper; optimization; Taguchi method

1 INTRODUCTION

Thanks to its advantages given to patients, Laparoscopic Surgery is a fast-growing surgery type [1]. It provides several advantages to patient such as shorter healing process in the post-operative period and shorter hospital stay, and less trauma [2-6]. In Laparoscopic surgery, specially-designed grippers are used to grasp and move organs safely [7-11]. The performance of these grippers depends on the surgeon's skills and experience, ease of use of gripper, the medical and technical functionality of the gripper. The most important feature of the grippers used to grasp flexible and sensitive tissues is safe-grasping. Safe-grasping is to prevent a gripper-induced negative event that will endanger the patient's physical well-being during the operation.

This study aims to introduce a Pneumatic-type non-contact gripper that works using air with Bernoulli's principle to ensure grasping, lifting and handling the tissues in the Laparoscopic surgery without applying any clamping force and to test this mentioned gripper for tissue-lifting performances in terms of the maximum air speed it can create. The Taguchi method, which is widely used in the scientific field for reducing the number of experiments and optimization, has been used for the same purposes in this study [12-21].

In this study, 5 grippers aiming to prevent gripper-induced tissue damages when grasping tissues in the Laparoscopic surgery have been designed and produced. In order to test the performances of these produced grippers, an experimental setup has been created. Taguchi method was used for experimental design and optimization. For the experimental parameters, five different gripper types, five different inlet pressures, five different air flows were selected. The number of experiments was reduced by using the Taguchi L_{25} orthogonal sequence and in the conducted experiments, the maximum air velocities that the grippers can generate under the specified conditions have been measured. Experimental results were evaluated with signal to noise ratio (S/N), three-dimensional graphics, and analysis of variance, by applying regression method, a mathematical model has been obtained for experimental design. In

addition, 3 verification tests have been carried out and thus, the accuracy of the optimization has been tested.

2 MATERIAL AND METHOD

A total of 5 pneumatic-type non-contact Laparoscopic grippers that work using air with Bernoulli's principle have been designed and produced in this study.

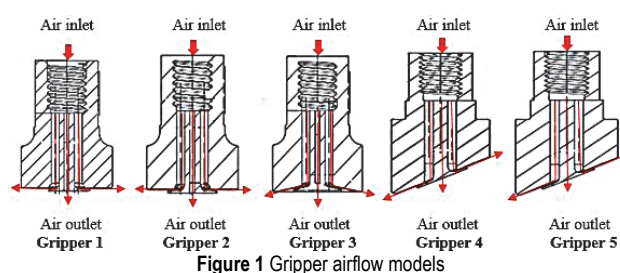

Figure 1 Gripper airflow models

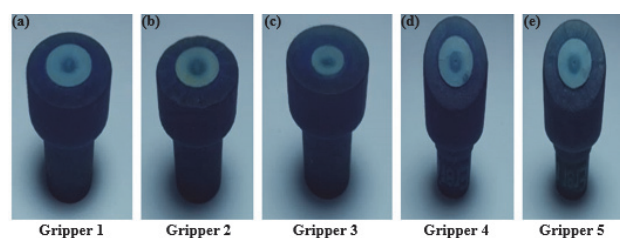

Figure 2 Laparoscopic gripper models used in experiments

Fig. 1 shows the full sections demonstrating the airflow of the grippers produced for the experiments, while Fig. 2 shows their solid models. The grippers have been produced from the biocompatible liquid resin using a 3D System, Projet 3510 HD Plus model 3-D printer in 32-micron precession. The grippers generally consist of two fixed parts: the gripper surface and the deflector. In the gripper designs, in order to keep flexible and sensitive materials without damaging the strong air jet, a deflector has been inserted in the central surface of gripper to provide to deflect the compressed air that flows from the centre of gripper without striking directly the object to be lifted. The gripper surface area of Gripper 1, Gripper 2, and Gripper 3 is 154 mm², while their outer diameter is 14 mm, hole diameter 6 mm,

and length 20 mm. Deflector diameters of Gripper 1, Gripper 2, and Gripper 3 are respectively: 6,5 mm, 7,5 mm, and 5,5 mm. To create a gripper surface and deflector in Gripper 4 and Gripper 5, a 30-degree angle was used. To contribute to the lifting force, for the purpose of increasing the air speed on the gripper surface, 12 venturi flumes have been canalized on the surface of Gripper 2 and 8 on the surface of Gripper 5. 0,8 mm diameter holes have been drilled in the centre of all grippers.

In order to test the maximum air speed that the five grippers can create on the gripper surface under specified conditions, the experimental setup which is shown in Fig. 3, and the experimental system, the schematic view of which is given in Fig. 4 have been set up.

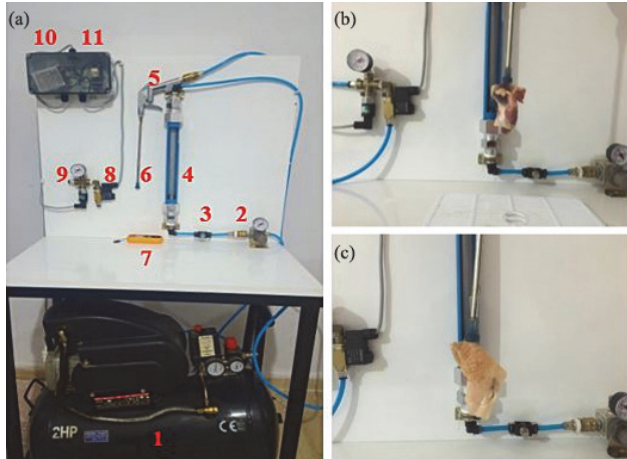

Figure 3 a) experimental setup, lifting of b) gizzard and c) skin

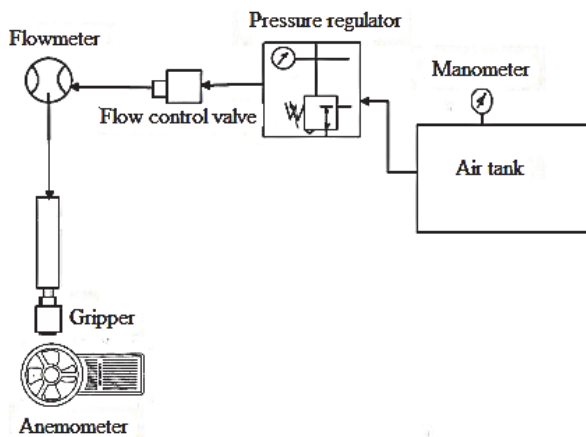

Figure 4 Schematic view of experimental setup

In Fig. 3a, the numbers given indicate as follow: 1. Compressor and air tank, 2. Pressure regulator, 3. Unidirectional flow control valve, 4. Flowmeter, 5. Air hammer, 6. Gripper, 7. Anemometer, 8. Solenoid valve, 9. Pressure sensor, 10. Adapter, 11. Relay; Fig. 3b indicates the lifting of gizzard, which is a non-viable chicken organ, and Fig. 3c skin.

In the experiments, a 50-liter capacity air tank, a maximum 8 bar pressure and a 200 l/min flow-capacity air compressor has been used. A manometer has been used to measure the pressure of the air entering the system. Air speed has been regulated with a unidirectional flow control valve, while airflow was regulated with a flowmeter.

3 EXPERIMENTAL DESIGN AND OPTIMIZATION

3.1 Experimental Design and Performing Experiments

It is possible to significantly reduce the number of experiments by the analyses made with the Taguchi method. In the Taguchi method, some functions are used to determine the quality characteristics. These functions convert the acquired data into the signal to noise ratio (S/N ratio). Three different equations are used for S/N ratio conversion: "nominal the best", "larger the better", and "smaller the better". Since the greatest value for the air speed measured in each experiment is desired, the "larger the better" function has been used in this study (Eq. (1)).

$$\text{Larger the better: } \eta = S / N_L = -10 \log \left(\frac{1}{n} \sum_{i=1}^n \frac{1}{y^2} \right) \quad (1)$$

where n is the number of observed values, while y is the observed data. In the Taguchi method, the choice of orthogonal sequence depends on the factors selected, interactions of these factors, the number of levels for each factor, and the purpose of the experiment. Therefore, for the correct orthogonal sequence selection, the test parameters and levels are determined first. Tab. 1 shows the selected test parameters and levels of these parameters.

Table 1 Test parameters and levels selected as control factors

Parameters	Level 1	Level 2	Level 3	Level 4	Level 5
Grippers, N_t	1	2	3	4	5
Air pressure, A_p / bar	3,0	4,0	5,0	6,0	6,5
Flow rate, F_r / m ³ /h	2,0	2,2	2,4	2,6	2,8

The first step of the Taguchi method is to choose a convenient orthogonal sequence based on test parameters selected as control factors. The most convenient sequence [$L_{25} (5^3)$] has been chosen to determine the optimum air speed parameters and analyse the effects of these determined parameters. Therefore, Taguchi L_{25} orthogonal sequence has been used for experimental design and 25 experiments have been performed. Optimization of the air speed values measured as a result of the experiments performed has been provided with S/N ratios. Tab. 2 shows the maximum air speed values measured by experiments performed according to the L_{25} Taguchi experiment design and S/N ratios measured using Eq. (1).

As a result of 25 experiments performed, the average air speed has been found to be 7,112 m/s and the average S/N ratio has been 16,9153 dB.

3.2 Determination of Optimum Parameters

In Tab. 3, the test parameters, which are expressed as control factors, are differentiated according to the selected orthogonal sequence, considering the different levels and possible effects. These levels show the signal to noise ratios calculated for the analysis of air speed measurements in the experimental study and the average values for each level of the speed values. These values are used to calculate the estimated values for the determined optimum parameters.

Another requirement for optimum value measurement is to determine the optimum levels. Optimum levels can be

determined by evaluating different levels of control factors based on the results of combinations produced by the L_{25}

orthogonal sequence. These levels are used to draw the main effects plots (Fig. 5).

Table 2 Air speed values and SN ratios obtained from experiments

Test No.	Control factors			Air speed / m/s	Signal-to-Noise (S/N) ratio
	Gripper type, Nt	Air pressure, Ap	Flow rate, Fr	Air speed, As	S/N
1	Gripper 1	3,0	2,0	6,0	15,5630
2	Gripper 1	4,0	2,2	7,4	17,3846
3	Gripper 1	5,0	2,4	8,3	18,3816
4	Gripper 1	6,0	2,6	9,2	19,2758
5	Gripper 1	6,5	2,8	10,3	20,2567
6	Gripper 2	3,0	2,2	6,4	16,1236
7	Gripper 2	4,0	2,4	7,3	17,2665
8	Gripper 2	5,0	2,6	8,4	18,4856
9	Gripper 2	6,0	2,8	9,6	19,6454
10	Gripper 2	6,5	2,0	6,1	15,7066
11	Gripper 3	3,0	2,4	6,6	16,3909
12	Gripper 3	4,0	2,6	7,4	17,3846
13	Gripper 3	5,0	2,8	8,3	18,3816
14	Gripper 3	6,0	2,0	6,5	16,2583
15	Gripper 3	6,5	2,2	6,8	16,6502
16	Gripper 4	3,0	2,6	5,5	14,8073
17	Gripper 4	4,0	2,8	6,7	16,5215
18	Gripper 4	5,0	2,0	5,8	15,2686
19	Gripper 4	6,0	2,2	6,2	15,8478
20	Gripper 4	6,5	2,4	6,9	16,7770
21	Gripper 5	3,0	2,8	6,3	15,9868
22	Gripper 5	4,0	2,0	5,6	14,9638
23	Gripper 5	5,0	2,2	5,8	15,2686
24	Gripper 5	6,0	2,4	7,0	16,9020
25	Gripper 5	6,5	2,6	7,4	17,3846

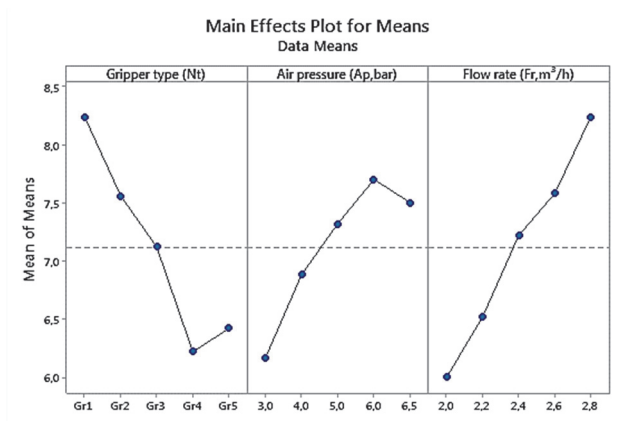

Figure 5 Effect graphs of experimental parameters for air speed

Fig. 5 shows the mean of air speed distributions measured based on control factors and levels. Since the "Larger the better" characteristic has been chosen in the study, the highest mean values for all levels have been evaluated to determine the optimal combination of control factors. Accordingly, the optimum combination of test parameters for air speed values is determined as $A_1B_4C_5$ (A_1 = Gripper 1, B_4 = 6 bar pressure and C_5 = 2,8 m³/h flow rate).

4 EVALUATION OF EXPERIMENTAL RESULTS

4.1 Effect of Test Parameters on Air Speed

Fig. 6 shows the effect of grippers and air pressure on air speed. Here, it is seen that air speed increases at Gripper 1 and 6,5 bar pressure. This is similar to the optimized parameters obtained with the Taguchi method. Gripper 2 has 12 venturi flumes, while Gripper 5, 8 venturi flumes; Gripper 4 and Gripper 5 have 10-degree angle surface. From this point of view, these characteristics affect the

performance of the grippers negatively at low air pressure and positively at high air pressure. In addition, when Gripper 3 and Gripper 4 are examined, it is identified that these grippers perform better at low air pressure than Gripper 1, Gripper 2, and Gripper 5.

Fig. 6b shows the effects of grippers and flow rate on air speed. Here, again Gripper 1 has shown the best performance. Analysing the graph, it is seen that Gripper 3 and Gripper 4 are at low flow rate and Gripper 1 is at the highest flow rate. According to this graph, therefore, Gripper 3 and Gripper 4 are recommended for low level of flow rate and Gripper 1 is recommended for high level of flow rate.

Fig. 6c shows the effects of air pressure and flow rate on air speed. It can be understood from this graphic that as the air pressure and flow increases, the air speed increases.

Fig. 6d shows the effects of flow and air pressure on speed. Here, it is seen that the best lifting performance is at 6,5 bar pressure and 2,8 m³/h flow rate. This is similar to the parameters optimized with Taguchi.

Table 3 S/N ratios (dB) and average weight values

Control Factors	Air Speed, As / m/s		
	Nt	Ap	Fr
S/N ratios / dB			
Level 1	18,17	15,77	15,55
Level 2	17,45	16,70	16,25
Level 3	17,01	17,16	17,14
Level 4	15,84	17,59	17,47
Level 5	16,10	17,36	18,16
Delta	2,33	1,81	2,61
Means / m/s			
Level 1	8,24	6,16	6,00
Level 2	7,56	6,88	6,52
Level 3	7,12	7,32	7,22
Level 4	6,22	7,70	7,58
Level 5	6,42	7,50	8,24
Delta	2,02	1,54	2,24

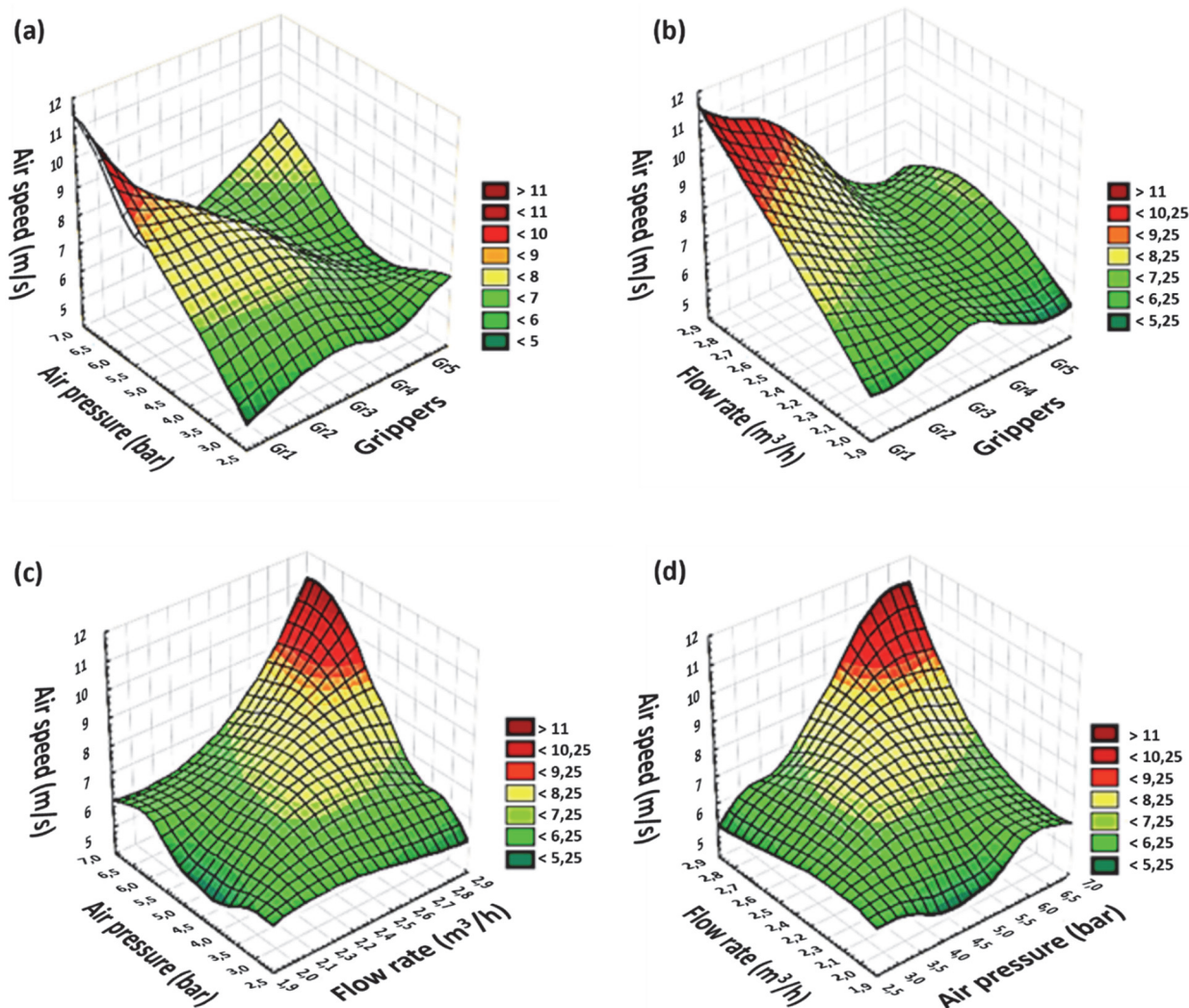

Figure 6 Effect of test parameters on air speed

4.2 Evaluation of Test Parameters by Analysis of Variance (ANOVA)

To determine how all control factors used in experimental design affect each other, how this has an effect on performance characteristics, and what changes in parameters of performance at different levels of parameters occur, analysis of variance is used.

The effects of gripper type, air pressure and flow rate on air speed values have been evaluated by analysis of variance, and test results have been examined at a 95% confidence level. Tab. 4 shows the results of analysis of variance.

Examining the results of analysis of variance in Tab. 4, the most effective factor affecting the air speed values has been the flow with 39,59%. It is followed by the nozzle type with 35,20%. The air pressure effect was 19,21%.

Table 4 Analysis of variance (ANOVA) for experimental results

Variance Source						
Air Speed, A_s / m/s	Degree of Freedom (df)	Sum of Squares (SS)	Mean Squares (MS)	F-value	p-value	Contribution Rate / %
Nt	4	13,738	3,4346	17,62	0,000	35,20
Ap	4	7,498	1,8746	9,62	0,001	19,21
Fr	4	15,450	3,8626	19,81	0,000	39,59
Error	12	2,339	0,1949	–	–	5,99
Total	24	39,026	–	–	–	100,00

4.3 Regression Analysis and Mathematical Model

Regression analysis is used in modelling and analysing various variables that have a relationship between a dependent variable and one or more independent variables. In this study, the speed equation has been obtained with the 3rd order polynomial regression (cubic regression) model for air speed results and the R -sq value of this model has been found to be 92,63. Eq. (2) shows the model obtained.

$$A_s = -0,4 + 0,64Nt - 0,85Ap + 3,28Fr - 0,552Nt^2 + 0,43Ap^2 - 0,11Fr^2 + 0,717Nt^3 - 0,0396Ap^3 \quad (2)$$

4.4 Verification Experiments

The purpose of validation experiments, the last step of the Taguchi method, is to analyse quality requirements. Also, to test the accuracy of the optimization process,

verification experiments are used. Verification experiments are carried out to test the optimum combination of test parameters and levels determined. According to the optimum combination for the air speed, taking into account the individual effects of the test parameters, $A_1B_4C_5$ ($A_1 =$ Gripper 1, $B_4 = 6$ bar, $C_5 = 2,8$ m³/h flow rate), the estimated speed value (A_p) is calculated according to the equation given below.

$$\eta_g = A_1 + B_4 + C_5 - 3\eta_{S/N} \tag{3}$$

$$A_p = 10^{\eta_g/20} \tag{4}$$

In the equations, $A_1B_4C_5$ is the signal to noise ratios of the optimum levels of the factors. η_g is the S/N ratio measured for optimum levels and $\eta_{S/N}$ speed values are the mean S/N ratios. A_p is the estimated value for speed. Estimation value measured using Eq. (3) and Eq. (4) for air speed has been found as 1,4421. Confidence interval (CI) is used in comparing the results of the verification experiments with the estimated value and verifying the quality characteristics. The confidence interval is the maximum and minimum value, and the accuracy of the verification experiments is tested by comparing the calculated value with the estimated air speed value. CI is measured by the equation given below.

$$CI = \sqrt{F_{\alpha;1,V_e} \times V_{ep} \times \left(\frac{1}{n_{eff}} + \frac{1}{r} \right)} \tag{5}$$

In Eq. (5), $F_{\alpha;1,V_e}$ ($F_{1,12} = 4,75$ from F table) refers to the ratio of significance level α to F , while α significance level (95%); V_e , degree of freedom of error ($V_e = 12$); V_{ep} , variance of error ($V_{ep} = 01949$); r , number of validation experiments; and n_{eff} , the number of effectively measured results.

$$n_{eff} = \frac{N}{1 + V_t} \tag{6}$$

In Eq. (6), N refers to the total number of experiments (25), while V_t indicates the total degree of freedom of the experimental parameters for which the average is measured considering Tab. 4. In this study, 3 verification experiments have been carried out considering the optimum combination determined for the maximum air velocities measured. Considering these values, n_{eff} for the measured speed has been found as 1,9230. When the test results are examined within a 95% confidence interval and Eq. (5) and Eq. (6) is considered, the confidence interval for the measured speed values has been found as $(CI) = 0,8887$. The mean of 3 experiments carried out for the accuracy and confidence interval calculation of the optimization was 9,9333 m/s. In this case, the interval of $(9,956 - 0,8887) < 9,9333 < (9,956 + 0,8887) = 9,0673 < 9,9333 < 10,8447$ has been obtained and validation experiments took place within the confidence interval. Therefore, optimization has been successfully accomplished. Tab. 5 shows the predicted values obtained using the Taguchi method and comparison of experiment results. The predicted values and experimental values are

very close to each other. Error values should be less than 20% for reliable statistical analysis [22, 23].

Table 5 Comparison of experimental combinations with predicted values

Levels	Air Speed / m/s		
	Experimental	Prediction	Error / %
$A_1B_4C_5$ (Optimum)	9,9333	9,956	0,2285
$A_2B_5C_1$ (Random)	6,1000	6,836	12,0650

Tab. 5 shows the comparison of experimental results of air speed to the predicted optimal combinations. It is seen that the difference between the results of the verification test and the results obtained by the Taguchi method is very low. In this case, it is understood from the results obtained with the verification experiments that the optimization has been carried out successfully.

5 CONCLUSION

In Laparoscopic surgery, toothed grippers are used to prevent organs slipping from grippers. Since it is not possible to take any tactile feedback when grasping, there is a risk of damage to organs as a result of the clamping force. In this study, 5 different grippers that can eliminate this risk have been designed and produced. After the production, the maximum air velocities that the grippers can create are examined with different parameters. Taguchi method has been used to reduce both time and experimental costs. For the experimental design, Taguchi L_{25} orthogonal sequence has been selected and a total of 25 experiments have been performed. Experimental results have been evaluated by three-dimensional graphics and analysis of variance, while a mathematical model with 92,63% R^2 value has been obtained using regression method.

It is possible to list the results obtained from the study as follows:

- For the experiments, 5 non-contact grippers with different structures have been designed, produced using a 3-D printer. A special experimental setup has been designed to carry out the experiments.
- As a result of 25 experiments performed, the effects of experimental parameters have been evaluated with three-dimensional graphics. As a result of this evaluation, it is recommended to use Gripper 1 if high air pressure will be used, Gripper 2, Gripper 4, Gripper 5 for low air pressure.
- In the evaluation based on the graphics, it is recommended to use Gripper 3 and Gripper 5 for low flow rate, while Gripper 1 and Gripper 2 for high flow rate.
- Gripper 1 has shown the best performance according to experimental results and the result of optimization has also confirmed this result.
- The optimum combination acquired after optimization has been obtained as $A_1B_4C_5$ ($A_1 =$ Gripper 1, $B_4 = 6$ bar, $C_5 = 2,8$ m³/h flow rate). This result has been confirmed by three-dimensional graphics.
- Three verification experiments have been carried out for the accuracy of the optimization, and these results occurred within the measured confidence interval.
- According to the results of variance analysis, the most effective factor has been the flow with 39,59%. It is followed by the nozzle type with 35,20%. The air pressure effect, on the other hand, has been 19,21%.

- Comparing the mean of the predicted value and verification experiments measured by Taguchi method, error rate has been 0,2285%.

The methods used in this study, which is important for Laparoscopic surgery, are thought to be a reference for similar studies. The original aspect of this study is testing the performance of different types of grippers designed for Laparoscopic surgery field. Further studies may test the performance of each gripper in different animal tissues. By changing the gripper designs, new grippers can be designed and the performance of these new grippers can be evaluated.

6 REFERENCES

- [1] Dankelman, J., Grimbergen, C. A., & Stassen, H. G. (2005). *Engineering for patient safety: Issues in minimally invasive procedures*. New Jersey, London: Lawrence Erlbaum Associates. <https://doi.org/10.1201/b12473>
- [2] Cuschieri, A. (1995). Whither minimal access surgery: Tribulations and expectations. *The American Journal of Surgery*, 169(1), 9-19. [https://doi.org/10.1016/s0002-9610\(99\)80104-4](https://doi.org/10.1016/s0002-9610(99)80104-4)
- [3] Moreno-Egea, A., Torralba, J. A., Morales, G., Fernández, T., Guzmán, P., Hita, G., Girela E., Corral M., Campillo A., & Aguayo, J. L. (2005). Laparoscopic repair of secondary lumbar hernias: open vs. laparoscopic surgery. A prospective, nonrandomized study. *Cirugía Española*, 77(3), 159-162. [https://doi.org/10.1016/s0009-739x\(05\)70828-9](https://doi.org/10.1016/s0009-739x(05)70828-9)
- [4] Dedemadi, G., Sgourakis, G., Karaliotas, C., Christofides, T., & Kouraklis, G. (2006). Comparison of laparoscopic and open tension-free repair of recurrent inguinal hernias: a prospective randomized study. *Surgical Endoscopy and other Interventional Techniques*, 20(7), 1099-1104. <https://doi.org/10.1007/s00464-005-0621-8>
- [5] Roumm, A. R., Pizzi, L., Goldfarb, N. I., & Cohn, H. (2005). Minimally invasive: Minimally reimbursed? An examination of six laparoscopic surgical procedures. *Surgical Innovation*, 12(3), 261-287. <https://doi.org/10.1177/155335060501200313>
- [6] Stefanoni, M., Casciola, L., Ceccarelli, G., Spaziani, A., Conti, D., Bartoli, A., Di Zitti, L., Bellocchi, R., & Valeri, R. (2006). The biliopancreatic diversion. A comparison of laparoscopic and laparotomic techniques. *Minerva Chirurgica*, 61(3), 205-213.
- [7] Marucci, D. D., Shakeshaft, A. J., Cartmill, J. A., Cox, M. R., Adams, S. G., & Martin, C. J. (2000). Grasper trauma during laparoscopic cholecystectomy. *Australian and New Zealand Journal of Surgery*, 70(8), 578-581. <https://doi.org/10.1046/j.1440-1622.2000.01902.x>
- [8] Hu, T., Tholey, G., Desai, J. P., & Castellanos, A. E. (2004). Evaluation of a laparoscopic grasper with force feedback. *Surgical Endoscopy*, 18(5), 863-867. <https://doi.org/10.1007/s00464-003-8132-y>
- [9] Trejo, A., Jung, M.-C., Oleynikov, D., & Hallbeck, M. S. (2007). Effect of handle design and target location on insertion and aim with a laparoscopic surgical tool. *Applied Ergonomics*, 38(6), 745-753. <https://doi.org/10.1016/j.apergo.2006.12.004>
- [10] Marucci, D. D., Cartmill, J. A., Walsh, W. R., & Martin, C. J. (2000). Patterns of failure at the instrument-tissue interface. *Journal of Surgical Research*, 93(1), 16-20. <https://doi.org/10.1006/jsre.2000.5906>
- [11] Shakeshaft, A. J., Cartmill, J. A., Walsh, W. R., & Martin, C. J. (2001). A curved edge moderates high pressure generated by a laparoscopic grasper. *Surgical Endoscopy*, 15(10), 1232-1234. <https://doi.org/doi.org/10.1007/s00464-001-0036-0>
- [12] Liu, Y., Liu, C., Liu, W., Ma, Y., Tang, S., Liang, C., Cai, Q., & Zhang, C. (2019). Optimization of parameters in laser powder deposition AlSi10Mg alloy using Taguchi method. *Optics & Laser Technology*, 111, 470-480. <https://doi.org/10.1016/j.optlastec.2018.10.030>
- [13] Nia, P. M., Jenatabadi, H. S., Woi, P. M., Abouzari-Lotf, E., & Alias, Y. (2019). The optimization of effective parameters for electrodeposition of reduced graphene oxide through Taguchi method to evaluate the charge transfer. *Measurement*, 137, 683-690. <https://doi.org/10.1016/j.measurement.2019.02.015>
- [14] Li, Y. & Zhu, L. (2019). Optimization of user experience in mobile application design by using a fuzzy analytic-network-process-based Taguchi method. *Applied Soft Computing*, 79, 268-282. <https://doi.org/10.1016/j.asoc.2019.03.048>
- [15] Akyalcin, S., Akyalcin, L., & Bjørgen, M. (2019). Optimization of desilication parameters of low-silica ZSM-12 by Taguchi method. *Microporous and Mesoporous Materials*, 273, 256-264. <https://doi.org/10.1016/j.micromeso.2018.07.014>
- [16] Zhang, R. & Wang, X. (2019). Parameter study and optimization of a half-vehicle suspension system model integrated with an arm-teeth regenerative shock absorber using Taguchi method. *Mechanical Systems and Signal Processing*, 126, 65-81. <https://doi.org/10.1016/j.ymssp.2019.02.020>
- [17] Kim, N. P., Cho, D., & Zielewski, M. (2019). Optimization of 3D printing parameters of Screw Type Extrusion (STE) for ceramics using the Taguchi method. *Ceramics International*, 45(2), 2351-2360. <https://doi.org/10.1016/j.ceramint.2018.10.152>
- [18] Jaison Baby, K. S. (2019). Optimization of Glass Fiber Reinforced Polymer (GFRP) using Multi Objective Taguchi function and TOPSIS. *Materials Today: Proceedings*, 11, 952-960. <https://doi.org/10.1016/j.matpr.2018.12.024>
- [19] Naik, A. B. & Reddy, A. C. (2018). Optimization of tensile strength in TIG welding using the Taguchi method and analysis of variance (ANOVA). *Thermal Science and Engineering Progress*, 8, 327-339. <https://doi.org/10.1016/j.tsep.2018.08.005>
- [20] Khare, S. K., Agarwal, S., & Srivastava, S. (2018). Analysis of surface roughness during turning operation by Taguchi Method. *Materials Today: Proceedings*, 5(14), 28089-28097. <https://doi.org/10.1016/j.matpr.2018.10.050>
- [21] Ai, L., Zhang, G., Li, W., Liu, G., & Liu, Q. (2018). Optimization of radial-type superconducting magnetic bearing using the Taguchi method. *Physica C: Superconductivity and Its Applications*, 550, 57-64. <https://doi.org/10.1016/j.physc.2018.03.013>
- [22] Kara, F. (2018). Optimization of surface roughness in finish milling of AISI P20+S plastic-mold steel. *Materials and Technology*, 52(2), 195-200. <https://doi.org/10.17222/mit.2017.088>
- [23] Erturk, S. & Samtas, G. (2019). Design of grippers for laparoscopic surgery and optimization of experimental parameters for maximum tissue weight holding capacity. *Bulletin of the Polish Academy of Sciences: Technical Sciences*, 67(6), 1125-1132. <https://doi.org/10.24425/bpasts.2019.130894>

Contact Information:

Şenol ERTÜRK, PhD
Department of Mechanical Engineering, Faculty of Engineering,
Duzce Universitesi Konuralp Yerleskesi,
Konuralp Merkez, Duzce, TR 81620, Turkey
E-mail: senolerturk540@hotmail.com