

Annales
Instituti
Archeologici

Godišnjak
Instituta za
arheologiju

XVIII - 2022

UDK 902/904
ISSN: 1848 6363



Glavna i odgovorna urednica / Editor in chief
Katarina Botić

Tehnički urednici / Technical editors
Katarina Botić
Marko Dizdar

Uredništvo / Editorial board
Marko Dizdar, Institut za arheologiju, Zagreb, Hrvatska
Hrvoje Kalafatić, Institut za arheologiju, Zagreb, Hrvatska
Ana Konestra, Institut za arheologiju, Zagreb, Hrvatska
Siniša Krznar, Institut za arheologiju, Zagreb, Hrvatska
Andreja Kudelić, Institut za arheologiju, Zagreb, Hrvatska
Bartul Šiljeg, Institut za arheologiju, Zagreb, Hrvatska
Asja Tonc, Institut za arheologiju, Zagreb, Hrvatska
Marina Ugarković, Institut za arheologiju, Zagreb, Hrvatska
Mario Gavranović, Austrian Archaeological Institute, Austrian Academy of Sciences, Vienna, Austria
Boštjan Laharnar, Narodni muzej Slovenije, Ljubljana, Slovenija
Alenka Tomaž, Fakulteta za humanistične studije, Univerza na Primorskem, Koper, Slovenija
Vesna Bikić, Arheološki institut, Beograd, Srbija
Perica Špehar, Filozofski fakultet, Univerzitet u Beogradu, Srbija
Miklós Takács, BTK Institute of Archaeology, Research Centre for the Humanities ELKH, Budapest, Hungary

Izdavački savjet / Editorial committee

Juraj Belaj, Institut za arheologiju, Zagreb, Hrvatska
Saša Kovačević, Institut za arheologiju, Zagreb, Hrvatska
Goranka Lipovac Vrkljan, Institut za arheologiju, Zagreb, Hrvatska
Daria Ložnjak Dizdar, Institut za arheologiju, Zagreb, Hrvatska
Branka Migotti, Zagreb, Hrvatska
Ivana Ožanić Roguljić, Institut za arheologiju, Zagreb, Hrvatska
Ante Rendić-Miočević, Zagreb, Hrvatska
Tajana Sekelj Ivančan, Institut za arheologiju, Zagreb, Hrvatska
Tihomila Težak-Gregl, Zagreb, Hrvatska
Tatjana Tkalčec, Institut za arheologiju, Zagreb, Hrvatska
Željko Tomičić, Hrvatska akademija znanosti i umjetnosti, Zagreb, Hrvatska
Ante Uglešić, Sveučilište u Zadru, Odjel za arheologiju, Zadar, Hrvatska
Snježana Vrdoljak, Institut za arheologiju, Zagreb, Hrvatska

Prijevod na engleski / English translation
Marko Maras i autori

Lektura / Language editor
Katarina Botić i autori (hrvatski jezik/Croatian)
Marko Maras (engleski jezik/English)

Nakladnik / Publisher
Institut za Arheologiju
Institute of Archaeology

Adresa uredništva / Editor's office address

Institut za arheologiju
/ Institute of Archaeology
Jurjevska ulica 15
HR-10000 Zagreb
tel 385 (0) 1 615 0250
fax 385 (0) 1 605 5806
e-mail: iarh@iarh.hr
web: http://www.iarh.hr

Dizajn / Design
Umjetnička organizacija OAZA

Korektura / Proofreaders
Katarina Botić
Ana Konestra
Asja Tonc

Računalni slog / Layout
Hrvoje Jambreč

Annales Instituti Archaeologici uključeni su u indekse: Clarivate Analytics services – Emerging Sources Citation Index, SciVerse Scopus – Elsevier, Amsterdam. / Annales Instituti Archaeologici are included in the indexes: Clarivate Analytics services – Emerging Sources Citation Index, SciVerse Scopus – Elsevier, Amsterdam.

Izrađeno uz financijsku potporu Ministarstva znanosti i obrazovanja Republike Hrvatske. / Made with the financial support of the Ministry of Science and Education of the Republic of Croatia.

E-izdanja. Publikacija je dostupna u digitalnom obliku i otvorenom pristupu na <https://hrcak.srce.hr/en/aia> / E-edition. The publication is available in digital and open access form at <https://hrcak.srce.hr/en/aia>

Ovaj rad licenciran je pod Creative Commons Attribution By 4.0 međunarodnom licencom. / This work is licenced under a Creative Commons Attribution By 4.0 International Licence.



Annales
Instituti
Archeologici

Godišnjak
Instituta za
arheologiju

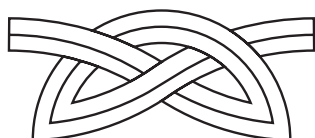

Prethodna priopćenja Preliminary reports

7–15

Daria Ložnjak Dizdar
Lidija Miklik-Lozuk

Istraživanja kasnobrončanoga naselja u Novi Gradu na Savi 2021. godine

Exploring the Late Bronze Age settlement at Novi Grad na Savi in 2021

16–34

Tatjana Tkalčec
Marko Dizdar

Rezultati zaštitnih istraživanja kasnolatenskoga naselja Lozan – Lendava u Podravini

The results of the rescue excavations at the Late La Tene settlement of Lozan – Lendava in the Drava Valley

35–62

Marina Ugarković
Ana Konestra
Martina Korić
Antonela Barbir
Eduard Visković

Arheološko istraživanje u Ulici Ivana Pavla II (tzv. parcela Lupi) u Starome Gradu na otoku Hvaru (2021.)

Archaeological excavations on Ivana Pavla II Street (the so-called Lupi plot) in Stari Grad on the island of Hvar (2021)

63–75

Asja Tonec
Marko Dizdar
Hrvoje Vulić

Nalazi rimske vojne opreme i konjske orme s nalazišta Ostrovo – Sokolovac

Finds of Roman military equipment and horse harness from the site of Ostrovo – Sokolovac

76–87

Jere Drpić

Prostorna analiza rimske ceste: *Incerto – Stravianis – Mursa*. Brdska dionica

Spatial analysis of a Roman road: *Incerto – Stravianis – Mursa*. Hill section

88–119

Bartosz Nowacki
Ana Konestra
Fabian Welc

Preliminary typology and contextual analysis of Roman and late antique cooking wares from the Roman rural settlement at Podšilo bay on the island of Rab (north-eastern Adriatic, Croatia)

Preliminarna tipologija i kontekstualna analiza rimskoga i kasnoantičkoga kuhinjskog posuđa iz antičkoga ruralnog naselja u uvali Podšilo na otoku Rabu (sjeveroistočni Jadran, Hrvatska)

120–130

Ana Konestra
Gaetano Benčić
Enrico Cirelli
Klaudia Bartolić Sironić
Ilaria Sommariva

Ecclesia S. Mariae de Turre cum capellis suis – identification of an earlier phase of the Church of the Holy Cross at Tar – Stancija Blek (Tar-Vabriga – Torre-Abrega, Istria)

Ecclesia S. Mariae de Turre cum capellis suis – utvrđivanje ranije faze crkve sv. Križa na lokalitetu Tar – Stancija Blek (Tar-Vabriga – Torre-Abrega, Istra)

131–142

Maja Zeman
Suzana Damiani
Marta Perkić
Ivana Ožanić Roguljić
Kristina Turkalj

Otkrivanje starih dubrovačkih katedrala. Istraživačke aktivnosti i međunarodna suradnja 2020. – 2022.

Discovering the Old Dubrovnik Cathedrals. Research Activities and the International Collaboration in 2020–2022

143–156

Juraj Belaj
Josip Pavić
Željko Krnčević

O arheološkim istraživanjima lokaliteta Mukoše kraj Goriša 2021. godine
On the archaeological excavation of the site of Mukoše near Goriš in 2021

157–163

Sebastian Stingl

Romboidni brevar iz Novske
The rhomboid breverl from Novska

Pregledni radovi Review papers

164–179

Mia Marijan
Andreja Kudelić

Upotreba ognjišnih keramičkih predmeta u
domaćinstvima kasnog brončanog doba
The usage of hearth-related ceramic objects in
Late Bronze Age households

180–188

Snježana Vrdoljak

Kalupi za lijevanje šuplje sjekire na lokalitetu
Kalnik – Igrišće
The casting moulds for socketed axes from the
site Kalnik – Igrišće

189–201

Tea Kokotović

Rezultati antropološke analize ljudskih koštanih
ostataka s lokaliteta Mukoške kraj Goriša iz 2021.
godine
Results of the anthropological analysis of the
osteological material from Mukoške site near Goriš
from 2021

202–211

Antonela Barbir
Petar Crnčan

Usporedna malakološka zbirka kao znanstveni
alat u arheologiji
Comparative malacological collection as a
scientific tool in archaeology

Kratki projektni izvještaj Short project report

212–218

Marina Ugarković
Martina Korić

O aktivnostima i rezultatima prve godine projekta
*Transformiranje jadranskog kozmosa: otočnost,
povezanost i globalni identiteti pred-rimske
Dalmacije* (AdriaCos) (HRZZ UIP-2020-02-2419)
On the activities and results of the first year of
the project *Transforming the Adriatic cosmos:
insularity, connectivity, and glocal identities of
pre-Roman Dalmatia* (AdriaCos) (HRZZ UIP-2020-
02-2419)

Kratki terenski izvještaj Short field report

219–222

Daria Ložnjak Dizdar
Marko Dizdar

Istraživanja groblja pod tumulima u Dolini kod
Nove Gradiške 2021. godine
Excavations at the cemetery under the tumuli in
Dolina near Nova Gradiška in 2021

Karta nalazišta Map of sites

1. Ostrovo – Sokolovac
2. Novi Grad na Savi
3. brdska dionica rimske ceste *Incerto – Stravianis – Mursa*
4. Dolina
5. Novska
6. Lozan – Lendava
7. Kalnik – Igrišće
8. Kurilovec – Belinščica
9. Tar – Stancija Blek
10. Rab – uvala Podšilo
11. Goriš – Mukoš
12. Hvar – Stari Grad
13. Dubrovnik



Preliminary typology and contextual analysis of Roman and late antique cooking wares from the Roman rural settlement at Podšilo bay on the island of Rab (north-eastern Adriatic, Croatia)

Preliminarna tipologija i kontekstualna analiza rimskoga i kasnoantičkoga kuhinjskog posuđa iz antičkoga ruralnog naselja u uvali Podšilo na otoku Rabu (sjeveroistočni Jadran, Hrvatska)

Prethodno priopćenje >
Antička arheologija
Preliminary report >
Roman archaeology

Bartosz Nowacki¹
Ana Konestra²
Fabian Welc¹

(1) Institute of Archaeology
Cardinal Stefan Wyszyński University
in Warsaw
Wóycickiego 1/3 (23)
PL-01-938 Warsaw
bm.nowacki@uw.edu.pl
ORCID: 0000-0002-9900-6407
f.welc@uksw.edu.pl
ORCID: 0000-0001-6122-1884
(2) Institute of Archaeology
Jurjevska ulica 15
HR-10000 Zagreb
ana.konestra@gmail.com
ORCID: 0000-0002-7726-6515

Primljeno Received: 05. 07. 2022.
Prihvaćeno Accepted: 17. 09. 2022.

Key words: Roman rural settlement, coarse cooking ware, late antiquity, eastern Adriatic

The paper presents a preliminary typology of coarse cooking ware from the Roman/late antique layers of the rural settlement at Podšilo bay on the island of Rab. The vessels have been associated with several basic shapes and divided by types, while fabrics have been described macroscopically. Analogies and a contextual analysis were used to propose dating and to assess provenience for well-known ware classes or to define areas of circulation for those with a more regional distribution. By analyzing the distribution within the settlement, we propose a tentative conclusion on their use within the latest phase of frequentation, and an attempt at understanding the culinary practices and household use of the ware.

Ključne riječi: Rimska ruralna naselja, gruba kuhinjska keramika, kasna antika, istočni Jadran

U radu se donosi preliminarna tipologija grube kuhinjske keramike iz rimskih/kasnoantičkih slojeva ruralnoga naselja u uvali Podšilo na otoku Rabu. Posude su interpretirane morfološki prema nekoliko osnovnih oblika i podijeljene u tipove, dok su keramičke strukture opisane na temelju makroskopskih opažanja. Analogije i kontekstualna analiza omogućile su prijedlog datacija te determinaciju provenijencije za keramičke klase šire distribucije odnosno definiciju distribucijskih zona za one regionalne cirkulacije. Analizom distribucije posuda unutar samoga lokaliteta donose se preliminarni zaključci o njihovom korištenju u zadnjoj fazi upotrebe prostora naselja, kao i kulinarskim praksama te kućanskoj upotrebi ovoga posuđa.

Introduction

As ascertained by recent multidisciplinary research (most recently in Konestra et al. 2020; Welc et al. 2019), the island of Rab (Kvarner Gulf, north-eastern Adriatic) was dotted by a number of rural productive-residential settlements in antiquity (tentatively *villae*), which developed both on its fertile fields and along the coast (Lipovac Vrkljan et al. 2017; Welc et al. 2019: Fig. 4; Konestra et al. 2021a: Fig. 2; Konestra et al. 2021b; see also Jurković, Turković 2019). Since 2016, research activities have been carried out at one such site, in Podšilo bay, on the Lopar Peninsula, in the northern part of the island (Fig. 1). The site was identified upon the discovery of a Roman ceramic kiln on the northern shore of the bay (Lipovac Vrkljan, Šiljeg 2010). Subsequently, reconnaissance of the severely eroded terraces in the hinterland of the bay identified numerous zones with pottery scatter and accumulations of allochthonous limestone semi-dressed blocks, in the form of cairns and drystone boundary walls, all hinting at the presence of a larger site. Since 2016, multidisciplinary geoarchaeological research allowed first to identify several zones with buried architectural remains and another kiln (Welc et al. 2017; 2019; Welc 2018), and then, thanks to targeted trial trenching, to better define two of these complexes located in the areas locally known as Podkućine and Beli Grad, respectively (Fig. 1). Combining the results of geophysical (GPR and magnetic) prospection and small-scale excavations, the structure at Podkućine was defined as a utilitarian building, ancillary to the larger settlement and possibly used for storage or some sort of production

activity (Fig. 2) (Konestra et al. 2019). On the other hand, the larger and more articulated complex at Beli Grad seems to have been the central residential and productive building of the settlement (or estate). Here, structures are laid around an open space, possibly a courtyard, developing into wings with multiple rooms. So far, the easternmost part of the complex has been excavated, revealing shallow stratigraphy and a small vat or basin of a yet undetermined function (Konestra et al. 2020: 233–237). Another trench, dug in a more central position in 2021, provided ample data on the architecture and phasing of the complex. In fact, walls here are partly preserved up to ca. 1 m of height, while post-holes and a hearth laid above a defunctionalized mortar pavement are indicative of a late phase of settling within the probably already ruined building (Fig. 2). The layers in question might be interpreted as abandonment and walking surface layers, the latter in phase with both the post-holes and the described hearth. A similar situation was also documented at Podkućine, where post-holes and a large refuse pit (Konestra et al. 2019: 188–190) indicate that this area too was subsequently used for habitation (Fig. 2).

Other finds recovered from these late layers, tentatively dated to the 5th and 6th c. AD, include a varied assemblage of coarse cooking wares accounting for a minimum number (MNI) of 41 individuals. These were the basis for a preliminary typology which might aid to date more precisely the last occupational phase, identify household activities and cooking habits, and determine regional connectivity and exchange patterns. Among the cooking wares, there stands out a series of probably residual sherds which will also be considered, as they provide

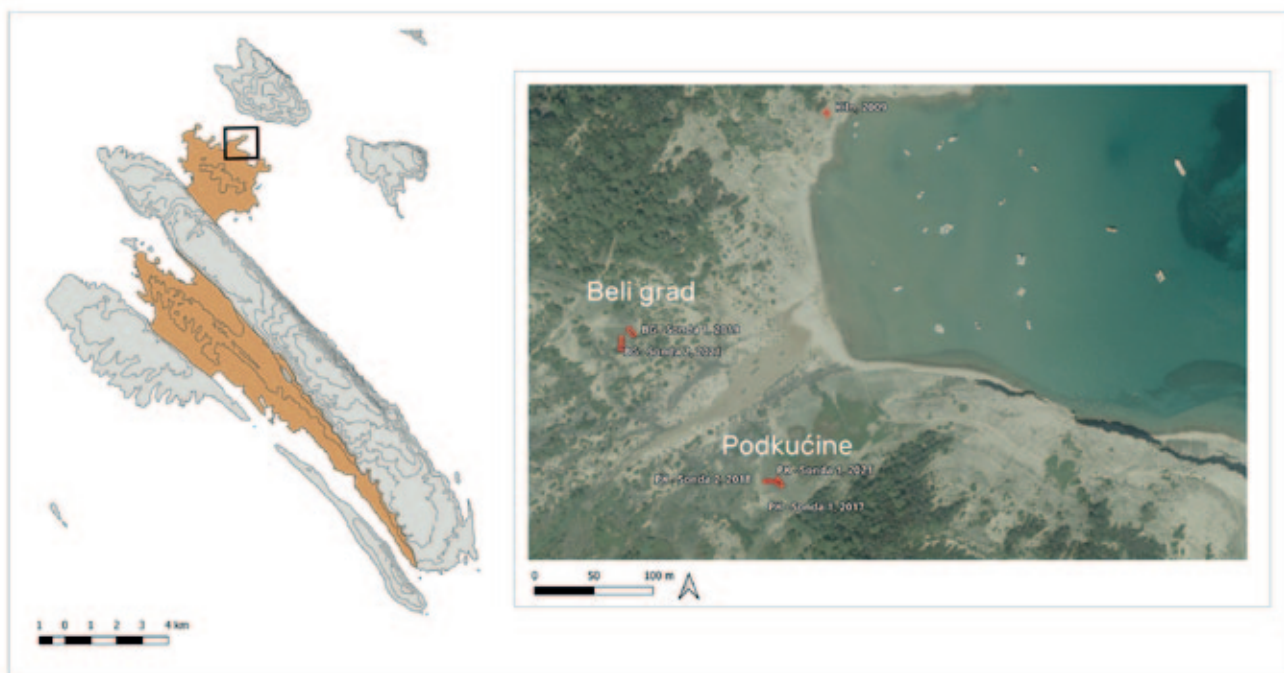

Fig. 1 Location of Podšilo bay on Rab Island (left); locations of trenches at Podkućine (PK) and Beli Grad (BG) (right) (made by: A. Konestra; basemaps: Croatian State Geodetic Administration and the Institute for Physical Planning of Primorje-Gorski Kotar County)

Sl. 1 Položaj uvale Podšilo na otoku Rabu (lijevo); položaji sondi na Podkućinama (PK) i Belom Gradu (BG) (desno) (izradila: A. Konestra; podloge: Državna geodetska uprava, javna ustanova Zavod za prostorno planiranje Primorsko-goranske županije)

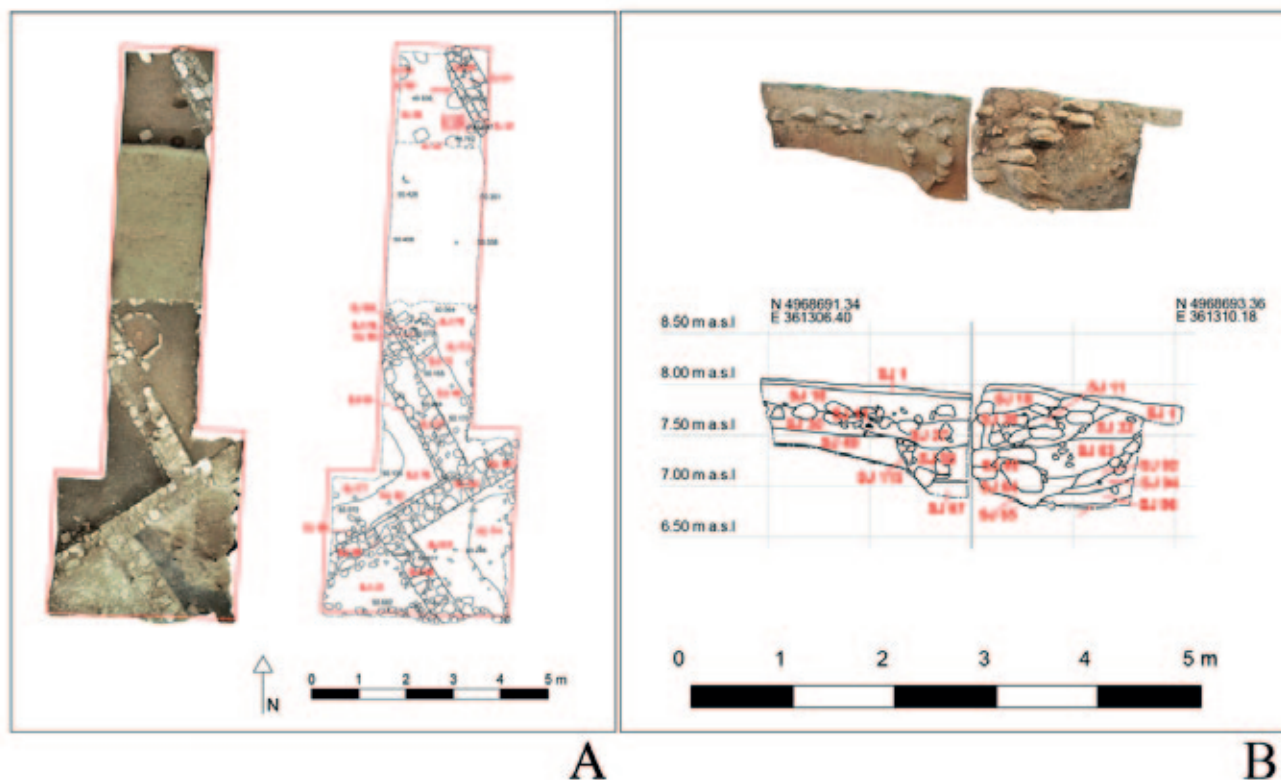

Fig. 2 Layout of Trench 2 at Beli Grad (A) and profile of the infill at Podkućine (B) after 2021 excavations (drawing and photos by: K. Rabięga)
 Sl. 2 Tlocrt Sonde 2 na Belom Gradu (A) i profil zapune unutar kompleksa na Podkućinama (B) nakon istraživanja 2021. godine (nacrtao i snimio: K. Rabięga)

a glimpse into the earlier phases of occupation.

The analysis of this pottery assemblage included a study of the vessels' morphology, function, and detailed macroscopic analysis of fabrics, while a programme of archaeometric research is being set up to analyse the latter aspect in more depth.

We will present the assemblage sorted by functional shapes: pots and bases, pans/casseroles, baking plates, baking covers, lids, and shapes of uncertain definition. All the data is summarised in Tab. 1, with a detailed description of the fabrics and analogies.

Cooking ware typology

I. Pots

Pots – closed vessels where the diameter of the opening is smaller than the maximum diameter, used for the cooking or storage of liquid and solid food – are by far the most numerous group of coarse ware vessels in the assemblage from the settlement at Podšilo bay. A total MNI of 24 vessels, together with the three bases, most likely belongs to pots, and makes up almost 66% of the assemblage. This should not come as a surprise, as pots dominate in most late antique coarse ware assemblages on numerous sites (e.g. Lavazza, Vitali 1994: 36), and their dominance is also reflected in late antique texts (Donnelly 2016: 227–230).

In most cases, these vessels were preserved only as rim sherds, while in one case (no. 13, Pl. 2: 13) it was possible to reconstruct a larger segment of the vessel, allowing the reconstruction (also based on analogies) of the shape of the entire pot. Eight vessels with a measured rim diameter are small pots with the rim diameter ranging from 10.6 to 14.2 cm. Fourteen vessels have a measured rim diameter exceeding 15 cm: from 15.8 cm to a maximum of 21.8 cm.

The presence of three sherds belonging to vessel bases (group II) most likely attributable to pots suggests that the majority of these vessels had a simple flat bottom, which is also backed by analogies (Gelichi 1983: 129; Riccato 2020: 199, 212).

All the vessels are uncoated. They were fired under various conditions – most often in a reduction atmosphere, a bit less often in a combined atmosphere, rarely in an oxidation atmosphere. The color of the surface depends mainly on the firing conditions – in an oxidation atmosphere the surface is pale brown, reddish yellow; in a combined atmosphere – brown; in a reduction atmosphere – dark brown, dark gray, and very dark gray. In most cases pots were formed on a potter's wheel, which is evidenced by the more or less clearly visible horizontal throwing marks on the inner surface. Only for vessels no. 1, no. 2 and no. 20 it can be assumed that they were hand-formed – their profile is irregular, and the inner and outer surfaces are ragged and unsmoothed.

Half of the vessels from this group have no decorations; the other 12 have incised decoration or

treatment of the surface, in most cases (seven vessels) in the form of thin, horizontal, parallel grooves on the shoulder. When such incisions occupy a larger segment of the vessel, and even its internal surface in some cases (nos. 3, 5–7), it might be suggested that these markings had a functional purpose, such as vessel handling or heat distribution (Cataldo 2012: 511; Cirelli 2021: 104). Two vessels (nos. 13, 16) have a wavy band (multiple lines) of low amplitude, large deviation, nervous, carved on the shoulder with a multi-point tool (comb?). Another two vessels (nos. 19, 23) are decorated on the shoulder with two multiple-line wavy bands. On one vessel (no. 17) the incised decoration on the shoulder is in the form of a band consisting of several horizontal parallel lines, with a strip of diagonal lines underneath.

The vessels belonging to the category of pots can be further divided into types classified primarily on the basis of the morphology of the rim, and, where possible, considering other parts of the body too.

I.1 Pots with thick vertical or everted rim and sharp internal break towards the body

This type includes three vessels with a short, slightly everted, narrowing rim, a rounded lip, and thick walls, and comes in slightly different sizes (see Tab. 1). The short neck continues into an unemphasised shoulder. At the break between the rim and the shoulder, the wall is clearly thickened, reaching a thickness of 1.1 cm or even 1.5 cm (no. 2; Pl. 1: 2).

Pots no. 1 and no. 2 are probably hand made – their profile is irregular, and the inner and outer surfaces are ragged and unsmoothed and without decorations. Pot no. 3 was formed on a potter's wheel – the profile is fairly regular, the inner surface of the rim and shoulder is densely covered with horizontal, parallel grooves, carved with a multi-point tool. On the outer surface, in the lower part of the rim and in the upper part of the shoulder, there is a decoration in the form of several incised, horizontal parallel grooves, made with a multi-point tool.

These pots were fired in reduction and in combined atmosphere. The ceramic material is hard – the surface cannot be scratched with a fingernail.

An analogy for pot no. 1, due to the thickness of the wall and the shape of the rim, can be pots of type I. B. from Guran – St. Cecilia in Istria (Ruffieux 2010: 259, Pl. 1: 2–3), dated to 400 – 550 AD. Similarities in shape can also be observed for an early medieval pot from Crkvina in Galovac (Belošević 1992: Pl. XLVII: 2), dated to the 8th – 10th century. An analogy for vessel no. 2 may be a pot from Classe near Ravenna (Cavalazzi, Fabbri 2010: 630, Fig. 4: 12), classified as an olla (type 10) of Italic production dated to phase 3, meaning the second half or end of the 6th century (Cavalazzi, Fabbri 2010: 624–625). For pot no. 3 we can find analogies in Croatia: in Veštar (Bekić 2014: 106, no. 22), dated to the 4th – 7th century, and at the Principia in Rijeka (Bekić

2009: Pl. 6: 11), dated to the 4th – 7th century. There are also some analogies in Italy, in Aquileia at Fondi Cossar – olla type 34.3 (Riccatò 2020: 215, Pl. XXI: 3), dating from the end of the 3rd to the 7th century, but the dating of the most similar analogies – a vessel from Cesena, Colle Garampo (Negrelli 2015: 147, Pl. 4: 8), and one from Sant'Agata Bolognese (olla type 3) (Sbarra 2014: 155, Pl. 3: 1) – is very broad, as similar pots are dated to the 6th century in the first case and the 9th – 11th century in the latter.

I.2. Pots with globular body and everted rim with square profile

This type includes five pots (nos. 4–8; Pl. 1: 4–7; 2: 8) with slightly everted rim with regular profile and flat, slightly rounded or slightly oblique (no. 4) lip, which most likely had a globular body.

All the examples of this type were formed on a potter's wheel – the profile is regular, and there are horizontal throwing marks or horizontal, parallel grooves, carved with a multi-point tool (comb?) on the inner surface under the rim. In the case of vessel no. 7, one band of parallel lines runs slightly obliquely. Moreover, the pots no. 5 and no. 7 have incised horizontal parallel grooves, carved with a multi-point tool on the outer surface under the rim.

Most pots of type I.2 were fired in a reduction atmosphere; only one vessel (no. 8) was fired in an oxidation atmosphere. The ceramic material is hard, the surface cannot be scratched with a fingernail.

In Croatia, good analogies for this type are the pots of type I. D. and I. F. from Guran – St. Cecilia (Ruffieux 2010: 259, Pl. 1: 9; 1: 12–13; 260, Pl. 2: 1–8), belonging to Assemblage 1 and dated to 400 – 550 AD. At Novi Vinodolski – Lopar, analogies are pots of type Ia (Vrančić, Janeš 2020: 181, Pl. 1: 1–5), dated from the 4th century to the Middle Ages. Other analogies can be found at the Principia in Rijeka (Bekić 2009: Pl. 6: 2, 7), dated to the 6th – 9th century, and at Banjače (Dugopolje area), where similar pots are dated to the 5th century (Ožanić Roguljić 2018: 191, Pl. 4: 46–47). In Slovenia, at Tonovcov grad, analogies can be found with pots of type 1 and 2 (Modrijan, Milavec 2011: 537, Pl. 87: 3; 540, Pl. 90: 3, 5, 7). In Italy, similar pots are known from Aquileia, Fondi Cossar, as type 3 (Riccatò 2020: 199, Pl. V: 2–3), type 34.2 (Riccatò 2020: 214, Pl. XX: 8), type 34.3 (Riccatò 2020: 215–216, Pl. XXI: 5; XXII: 2), and type 37 (Riccatò 2020: 219, Pl. XXV: 2–6). Pots from Aquileia are dated between the end of the 3rd and the 7th century AD, but with a greater incidence starting from the 5th century. Analogies to this type can also be found in Classe (Brogiolo, Gelichi 1986: 297, Pl. II: 2), where pots of this type are dated to the 6th – 7th century (Gelichi 1998: 481) and S. Maria in Pado Vetere (Corti 2007: 583, Fig. 12: 5–7), dated within the same timeframe.

I.3. Pots with globular body, everted rim with rounded profile and externally thickened/profiled lip

Type 3 includes seven pots (nos. 9–15; Pl. 2: 9–14; 3: 15), which are only slightly different from type 2 pots – most likely they had a similar globular body, but the rim has a more rounded profile (nos. 11, 12, 14), is more everted, externally slightly thickened, forming a flat, slightly rounded lip. In one case (no. 12) the lip is slightly oblique.

This type includes medium-sized pots formed on a potter's wheel – their profile is regular, the surface is well smoothed, and horizontal throwing marks are visible on the inner surface, under the rim.

Pots no. 11, 12 and 15 have incised horizontal parallel grooves, carved with a multi-point tool on the shoulder. In the case of pot no. 13, there are horizontal, parallel, and delicately defined traces of levigation by stick on the shoulder. On these lines, a single decorative band of multiple wavy lines was made with a multi-point tool. This wavy band is characterized by low amplitude and large deviation, resembling a zigzag pattern.

Type 3 pots were fired in reduction (nos. 9, 11), combined (nos. 12, 14–15), and oxidation atmosphere (nos. 10, 13). The ceramic material is hard, the surface cannot be scratched with a fingernail.

In Croatia, good analogies for pots of type 3 are again found at Guran – St. Cecilia: pots of type I. D. (Ruffieux 2010: 259. Pl. 1: 9), type I. E. (Ruffieux 2010: 259. Pl. 1: 10), type I. F. (Ruffieux 2010: 259. Pl. 1: 12–13; 260, Pl. 2: 1–8), and type I. H. (Ruffieux 2010: 261. Pl. 3: 7), again dated to the timeframe of 400 – 550 AD. Other Istrian analogies can be found at the Brijuni “Castrum” (Marušić 1986a: 88, Fig. 7: 2), dated to the 5th–6th century, and at Veštar (Bekić 2014: 106, nos. 13, 18), dated to the 4th–7th century. Numerous analogies are known from the Principia in Rijeka (Bekić 2009: Pl. 2: 3, 5; 4: 2–4), dated to the 4th–7th, or even the 9th century (Bekić 2009: Pl. 1: 5). At Novi Vinodolski – Lopar, analogies are pots of type Ie (Vrančić, Janeš 2020: 184, Pl. 2: 7) and pots of type 5a (Vrančić, Janeš 2020: 193, Pl. 5: 8; 196, Pl. 6: 1–2). At Tonovcov grad, good analogies are pots of type 4 (Modrijan, Milavec 2011: 541, Pl. 91: 15; 542, Pl. 92: 5–8; 543, Pl. 93: 1–7), which are most often found in layers dating back to the 6th century.

In Italy, analogies can be found at Classe (Brogiolo, Gelichi 1986: 297–298, Pl. II: 1–4; III: 1–2), dated to the 6th–7th century (Gelichi 1998: 481), at Invillino – pots of type III d4 (Bierbrauer 1987: Pl. 76: 3–5), dated from the first half of the 5th to the second half of the 7th century, at Villaggio San Francesco at Comacchio (Negrelli 2021: 207, Fig. 6: 7), dated to the 7th–8th century, at Aquileia – Fondi Cossar, pots of type 38 (Riccatò 2020: 219–220, Pl. XXV: 11; XXVI: 3, 5), dated mostly from the beginning of the 5th to the beginning of the 6th century. Other analogous pots were found at Oderzo, especially pots type 6 dated to the 7th–9th centuries (Castagna, Spagnol 1996: 85, Pl. 1: 13–16). In terms of dimensions, shape and decoration, vessel no. 13 fits perfectly the “Classe type” pots from Classe near Ravenna (Brogiolo,

Gelichi 1986: 297, Pl. II: 1–4), dated to the 6th–7th century (Gelichi 1998: 481; see also Guarnieri 2020: 271–273) and from S. Maria in Pado Vetere (Corti 2007: 574, Fig. 4: 4), where they are identically dated.

I.4. Pots with globular body, everted rim with rounded profile, thinned at the lip, with groove for the lid

Type 4 includes three pots, nos. 16–18 (Pl. 3: 16–18), likely to have had a globular or slightly barrel-shaped body. The rim with a rounded profile is everted, thinned at the lip, and has a groove for the lid. The lip is flat, slightly rounded (no. 16), or rounded.

This type includes quite large pots, formed on a potter's wheel – their profile is regular, the surface well smoothed, while horizontal throwing marks are visible on the inner surface under the rim. All the pots have incised decoration on the shoulder.

Type 4 pots were fired in an oxidation (no. 16) and combined atmosphere (nos. 17–18). The ceramic material is hard, the surface cannot be scratched with a fingernail.

Analogies are found at Guran – St. Cecilia, with pot no. 16 being similar to type I. H. (Ruffieux 2010: 261. Pl. 3: 4), dated to 400 – 550 AD. Pots no. 17 and 18 are similar in shape to pots of type 2 from Tonovcov grad (Modrijan, Milavec 2011: 540, Pl. 90: 6), dated to the second half of the 4th and the first half of the 5th century. The last two type 4 pots have analogies at Fondi Cossar in Aquileia – pots of type 39 (Riccatò 2020: 221, Pl. XXVII: 3), dated from the second quarter of the 5th century to the middle of the 6th century, and pots of type 40 (Riccatò 2020: 222, Pl. XXVIII: 1–2), dated to the 5th century. Decoration on pot no. 17 resembles a differently shaped vessel from the villa in Betiga near Barbariga, in Istria (Juroš-Mofardin 1986: Pl. IV: 5).

I.5. Pots with globular or biconical body, and slightly everted rim and rounded lip

Type 5 includes four pots (nos. 19–22, Pl. 3: 19; 4: 20–22) with a globular or biconical (no. 20) body, a slightly everted rim, and a rounded lip. Three vessels of this type were formed on a potter's wheel – the outer surface is smoothed, with smoothing marks on the inner surface of the rim. One vessel, no. 20, was most probably handmade, as sparse smoothing marks are visible only on the outer surface of the upper part of the shoulder. Pots nos. 20–22 have no decoration. Pots nos. 19, 20, 22 were fired in a combined atmosphere, pot no. 21 was fired in a reduction atmosphere. The ceramic material is generally hard; it is soft only in the case of pot no. 22 – the surface can be scratched with a fingernail.

The best-preserved vessel of this type is no. 19. The short neck immediately develops into an unemphasised shoulder. The shape of the shoulder suggests that the vessel may

have had an elongated shape. This pot, with a rim diameter of 20 cm, is also distinguished by its decoration: there are traces of levigation (polishing, smoothing) on the outer surface, especially on the neck; at least two wavy bands (multiple lines) are carved with a multi-point tool on the shoulder; there is also rendering on the inner surface in the form of vertical, parallel shallow grooves under the rim. Analogies are known from Koper in Slovenia (Cunja 1996: Pl. 36: 380) and tentatively from continental Croatia – type 1 pots from Virovitica – Kiškoriya (Jelinčić Vučković 2015: 131, Fig. 139; Pl. 23: 8 – pot no. 209, dated to the 2nd – 3rd century by its context).

For no. 20, an analogy is type IIIa2 from Invillino in Italy (Bierbrauer 1987: Pl. 106: 14), where group IIIa vessels are dated to the 4th – 7th century. The rim of no. 21 is very similar to the rims of type IIIc1 (Bierbrauer 1987: Pl. 74: 2–4), dated from the second half of the 4th century to the second half of the 7th century.

I.6. Pot with cylindrical body, everted and flattened rim

This type includes one vessel, no. 23 (Pl. 4: 23). It is a pot with a cylindrical body and slightly wavy body walls. It has short, almost horizontally everted rim and an obliquely undercut lip.

The vessel was formed on a potter's wheel – the profile is regular, the inner surface is well smoothed, with horizontal, parallel grooves carved with a narrow multi-point tool on the inner surface. The vessel has a rich incised decoration. The outer surface under the rim is densely covered with horizontal, parallel grooves, carved with a multi-point tool. On the grooves, in the upper part of the vessel, there are two incised multiple wavy lines (wavy bands with small amplitude and deviation); on the upper surface of the rim, which is strongly everted, there are carved multiple wavy lines.

No exact analogy could be found, either in terms of shape or decoration. Similar decoration can be observed on pots of type 1 from Ančnikovo Gradišče in Slovenia (Modrijan 2020: 322, Fig. 5: 1), while a hand-made pot from Ajdovski Gradec above Vranje near Sevnica (Knific 1994: Pl. 5: 7) has a similar shape and dimensions.

I.7. Pot with almost vertical rim with internal ridge (Fulford 35/ C.A.T.H.M.A 5)

The only representative of the type is pot no. 24 (Pl. 4: 24) with a conically expanding body, a slightly everted, almost vertical rim, a rounded lip, and an internal ridge. It is most probably an Aegean/eastern Mediterranean import.

The vessel was formed on a potter's wheel – the profile is regular, the inner surface of the shoulder is covered with horizontal,

parallel wheel throwing marks. On the outer surface of the neck and on the shoulder there are thin incised horizontal, parallel grooves.

The pot was fired in a combined atmosphere. The oval dark gray spot on the inner surface and the extensive traces of blackening on the outer surface may be associated with the use of the vessel on an open hearth.

A chrono-typology of these handled pots/casseroles – known as Fulford 35 or C.A.T.H.M.A. 5 (Fulford 1984: 187–189, Fig. 70; C.A.T.H.M.A. 1991: 35, Fig. 17) – of wider Ephesian or Samian, and possibly Phocian production (Turnovsky 2005: 637; Waksman, Trégliya 2007: 647–648; Warner Slane, Kiriatzi 2014: 910; Riccato 2020: 168) was developed by P. Turnovsky on the basis of materials from Ephesos, according to which the specimen from Podšilo might belong to a type dated to the mid-5th century (Turnovsky 2005: 636, Fig. 1).

There is a wide Mediterranean distribution of these vessels, starting from the 4th and lasting into the 7th century (Riccato 2020: 168–169 with ample earlier bibliography). Analogies from Croatia include Erošove bare in the environs of Narona (Mardešić, Šalov 2002: kat. 81, 91, 116, 199?), while the shape is also present at Ravenna (port area of Classe) (Cirelli, Cannavici 2014: Fig. 10: 6) and is fairly common at Aquileia as well (Riccato 2020: 168–169, Pl. LXVI: 8). It is also common in the 5th – 6th century layers at Durrës, Burrint, and Shkodër (Shkodra 2006: 448 with earlier bibliography).

II. Bases

II.1. Pots with flat base

All three bases most likely belong to pots. The first vessel (no. 25, Pl. 5: 25) was most likely globular, which is indicated by its slightly convex walls. The other two must have been more squat, due to a considerable diameter and almost straight walls. Two vessels were fired in a combined atmosphere (nos. 25, 27) and one in a combined-reduction atmosphere (no. 26). All three pots were made on a potter's wheel – there are barely visible horizontal, parallel grooves on the inner surface of the vessels. The outer surface was smoothed and covered at some distance from the bottom with incised horizontal, parallel grooves (no. 25) or very thin lines (nos. 26–27).

In the case of vessel no. 25, in terms of the shape and dimensions of the base, good analogies can be found at Guran – St. Cecilia in Istria, with very similar type V. B. bases stemming from Assemblage 1, dated to 400 – 550 AD (Ruffieux 2010: 264, Pl. 6: 5). For vessels no. 26 and no. 27, analogies are type 33 pots from Aquileia, Fondi Cossar, which have a similar shape of the base (Riccato 2020: 212–213, Pl. XVIII: 4; XIX: 2). In Aquileia, type 33 pots occur in contexts dated from the end of the 4th to the end of the 6th/early 7th century (Riccato 2020: 47).

III. Casseroles/pans

Vessels where the diameter of the opening is wider than the height of the vessel. Since mostly rims are preserved, it is difficult to reconstruct the original height, hence a differentiation within casseroles and pans is difficult, though analogies mostly indicate that the vessels were higher. Among the identified vessels there are imports from Tunisian workshops (perhaps as residuals?), along with shapes of more regional distribution.

III.1. Casseroles/pans with inverted rim

Two fragments of casserole/pan (nos. 28, 29, Pl. 5: 28–29) are shaped as deep bowls with an inverted rim and a rounded or narrowing and rounded lip. As shown by the analogies from Classe (Cavalazzi, Fabbri 2010: 627, Pl. 1: 1–4), both vessels had relatively straight walls, probably ending with a flat base.

The vessels were wheel thrown – there are throwing/smoothing marks on the inner surface, the outer surface is well smoothed; in the case of vessel no. 28 there are horizontal, parallel and delicately defined traces of levigation by stick.

Both vessels of this type were fired in a combined atmosphere; the ceramic material is hard – the vessel's surface cannot be scratched by a fingernail.

As mentioned, the best analogies can be found in northern Italy, at Classe (Cavalazzi, Fabbri 2010: 627, Pl. 1: 1–4), where the particularly relevant examples are those of casseroles from context 4381 from the port area (Cirelli, Cannavici 2014: 974, Fig. 10: 8–9), dated to 475 – 525 AD. Other analogies can be found at Fossa di Concordia (Corti 2001: Fig. 7: 46–48), S. Maria in Pado Vetere, and Salto del Lupo (Comacchio/FE) (Corti, Loschi Ghittoni 2007: 518–520, Fig. 2: 2; 4: 5; 5: 8–11).

III.2. ACW – Hayes 23B – Culinaire type 1

The sherd with a thickened rim, no. 30 (Pl. 5.30), most probably belongs to an African cooking ware Hayes 23 – Culinaire A type 1 casserole (Hayes 1972: 45–47; Bonifay 2004: 211). Although its fabric (of Munsell 2.5Y4/1 colour) was modified by use or post-depositional processes (e.g. exposure to fire), its morphology is fairly typical of a later 4th c. variant of the B type (Bonifay 2004: Fig. 112: 4). The shape is fairly common all over the Mediterranean, including the eastern Adriatic (e.g. Topić 2004: kat. 200–205; Pešić 2019: 309–310) and the island of Rab (Konestra et al. 2021b: 158, Fig. 8: 10).

III.3. Casserole with thickened rounded rim and biconical body

Several sherds of the rim and walls of a biconical casserole could be reconstructed (no.

31, Pl. 6: 31). The vessel is wheel thrown – there are horizontal, parallel and quite deep wheel throwing marks on the inner surface, and it was fired in a combined atmosphere – the break is brown (Munsell 7.5YR4/3). The ceramic material is hard – the vessel's surface cannot be scratched by a fingernail.

The vessel presents a fabric that resembles Aegean or eastern Mediterranean products, though mica is missing. Precise analogies have not been found, but a type from Ostia and Rome (*Basilica Hilariana*) (Ostia IV, Fig. 105; Bertoldi, Pacetti 2007: 435, casseruole tipo 8) might be suggested on the basis of shape only, since no description of their fabric is provided. At Rome, the shape is present in contexts of the 5th century (Bertoldi, Pacetti 2007: 433). The shape does resemble the Late Roman cooking pot 1 of ACW (late variant of Hayes 183) (Bonifay 2004: 227), but the fabric would hardly be comparable, unless severe use/post-depositional alterations occurred.

III.4 ACW – Hayes form 197 – Culinaire type 10

A small, very abraded sherd (no. 32, Pl. 6: 32) of the almond shaped rim with a groove for the lid of a Hayes 197 – Culinaire C/A type 10 belongs to the variants datable to the 4th century (Hayes 1972: 209; Bonifay 2004: 224, Fig. 120: 5, 6). Just like the previously mentioned ACW casserole, with which it might have formed a set for *bain-marie* cooking (Fentress 2010: 147), its distribution is very wide, with numerous occurrences on the eastern Adriatic too (e.g. Topić 2004: kat. 238–246; Pešić 2019: 317–319), including the island of Rab (Konestra et al. 2021b: 158, Fig. 8: 9).

IV. Baking plates

IV.1. Baking plates with flat shape and rounded lip

One sherd (no. 33, Pl. 6: 33) can be classified as a baking plate. It has a simple, flat shape with a rounded and thickened edge. The vessel was made by hand and its surface is uncoated. It was fired in an oxidation atmosphere. The fabric is hard – the pottery surface cannot be scratched by a fingernail.

According to T. Vida (2016: 391), baking plates were closely related to baking lids. In fact, they could have been used instead of an oven to bake bread or meat, by placing the food on the plate and covering it with a baking lid. It can therefore be assumed that such flat or slightly thickened plates constituted a baking set together with the dome-shaped lids. This is further indicated by the approximately same diameters of these vessels, which might range from 15 to 30 cm (Vida 2016: 391). The appearance of baking plates/flat baking pans has been noted in various parts of Europe in late antiquity and especially from the early Middle Ages (Arthur 2007b: 178; Cirelli 2021: 104).

Baking plates are known from the Kvarner and Istria (Bekić 2016: 120), but with L-shaped rims, and

most come from late antique contexts of the 5th – 7th century. Similar baking plates with L-shaped rims, dated to the 5th–7th century, are known from Tonovcov grad in Slovenia too (Modrijan 2010: 693, Pl. 5: 7–8). Flat plates of a similar shape to the object from Podšilo are known from the early medieval (7th–9th century) site of Horgoš/Horgos in Serbia (Vida 2016: 405, Fig. 19: 3–4).

V. Baking lids

Baking lids are dome-shaped vessels used as portable ovens, with food placed underneath them and hot embers piled on top and around them, allowing for slow, long baking of various dishes and bread (e.g. Cirelli 2021: 99). This kind of vessel is known from the Iron Age on the eastern Adriatic (e.g. Mihovilić 2014: 308–310; Čondić, Vuković 2017: 51) and elsewhere, as typical of the Roman Republican and early Imperial eras (Cubberley et al. 1988), to then slowly dwindle until late antiquity (see *infra*).

Since only small sherds of these vessels have been preserved, their complete form can be determined only in one case. The vessels belonging to the category of baking lids are further divided into types classified primarily by the morphology of the rim and, where possible, considering other parts of the vessel.

V.1. Baking lid with straight rim and rounded lip

The first type (no. 34; Pl. 6: 34) has a straight, slightly thickened rim and a rounded lip. The vessel was made on a potter's wheel, as indicated by the decoration on the outer surface, consisting of horizontal, parallel lines/grooves carved with a multi-point tool (comb?). In one place, under the lip, there is also a decoration with a few incised diagonal grooves. The vessel was fired in an oxidation atmosphere; the ceramic material is hard (it cannot be scratched by a fingernail).

For vessel no. 34, analogies are baking lids of type III. B. from Guran – St. Cecilia (Ruffieux 2010: 262–263, Pl. 4: 10–11; 5: 1–2), from assemblage 1, dated to 400 – 550 AD.

V.2. Baking lid with convex wall and thickened lip

Baking lid no. 35 (Pl. 6: 35) has a slightly convex wall, an upright rim, and a thickened lip. The vessel is wheel thrown – there are horizontal, parallel lines on the inner surface and a few on the outer surface. It was fired in an oxidation atmosphere; the ceramic material is hard (it cannot be scratched by a fingernail).

Analogies can be found among vessels from Guran – St. Cecilia (Ruffieux 2010: 262, Pl. 4: 9 – type III. A, dated to 400 – 550 AD), and in Italy, for e.g. at Sant'Agata Bolognese (Sbarra 2014: 166, Pl. 10: 5 – catini-coperchio Tipo 3).

V.3. Baking lid with convex wall and rounded lip

Baking lid no. 36 (Pl. 6: 36) has convex walls, an upright rim, and a rounded lip. The vessel was probably formed on a potter's wheel – the surface is well smoothed, with very delicate horizontal, parallel lines on the inner surface. On the outer surface there is a decoration in the form of numerous oblique, randomly arranged grooves.

This baking lid was probably fired in a reduction atmosphere (or was burned during use, because it shows traces of blackening on the outer surface and on the inner surface at the rim). The ceramic material is hard (it cannot be scratched by a fingernail).

Analogies can be found among vessels from Guran – St. Cecilia (Ruffieux 2010: 262, Pl. 4: 9 – type III. A, dated to 400 – 550 AD), and in Italy, e.g. in Classe (Brogiolo, Gelichi 1986: 298, Pl. III: 5).

V.4. Bowl-shaped baking lid with folded handles

Baking lid No. 37 (Pl. 6: 37) was most likely shaped as a flat-based bowl, as suggested by a fragment of a flat bottom with slightly rounded edges and a fragment of a wall with a slightly oblique, folded handle; thus, a possible reconstruction of the vessel's morphology can be proposed. The vessel was made on a potter's wheel – it is well smoothed, with very delicate horizontal, parallel lines on the inner surface. It was fired in an oxidation atmosphere; the ceramic material is hard.

Analogies can be found in Italy, e.g. in Milano (Vida 2016: 400, Fig. 12: 4), at Volta di Besta - Ledro B on Lago di Ledro (Vida 2016: 403, Fig. 17: 7), and in Austria at Teurnia / Sankt Peter in Holz (Rodriguez 1997: Pl. 4: 33, 36), dated to the 5th – 7th century.

VI. Lids

Lids, as functional vessels or rather objects, were used in conjunction with pots or casseroles, allowing for faster boiling and a smaller water loss, or in the case of storage vessels, for the protection of the vessels' contents. The ubiquity of use of pots and casseroles in conjunction with lids, a typically Mediterranean practice (Arthur 2007a: 16), is testified by the grooves on their rims, aimed at securing the covers more firmly. The three lid fragments represent only 7.3% of the total coarse ware assemblage.

VI.1. Lids with regular, concave and externally thickened rim

Two of the identified lids have regular, concave, and externally slightly thickened rims with flat, slightly rounded (no. 38, Pl. 7: 38) or flat lips (no. 39, Pl. 7: 39). Both vessels were made on a potter's wheel – there are delicate or quite distinct (no. 38) thin horizontal lines on the inner surface. The outer

surface is well smoothed. Lid no. 38 was fired in an oxidation atmosphere, with dark spots on the outer surface – presumably traces of blackening that occurred during cooking. Lid no. 39 presents basically the same morphological features.¹

The best analogy for no. 38 and 39 is a lid from Koper (Cunja 1996: Pl. 36: 390). It is shaped as a flat-truncated cone with concave walls, a slightly thickened rim, and a flat, slightly rounded lip, and its dimensions are similar to the example from Rab. In the case of vessel no. 38, the lid of type 4 from Aquileia – Fondi Cossar can also be an analogy (Riccatò 2020: 240, Pl. XLVI: 6), although this type is dated to the 1st – 2nd century AD.

VI.2. ACW – Hayes 196 – Culinare C/A type 11

The third lid (no. 40, Pl. 7: 40), with a thickened rim and a diameter of 34 cm, belongs to ACW Hayes 196 – Culinare C/A type 11, late variant (Hayes 1972: 207; Bonifay 2004: 226, Fig. 121). The shape is dated to the 4th c. or the beginning of the 5th c., and it can be associated with both previously mentioned casseroles forming a cooking set (Fentress 2010: 147). The distribution is equally widespread.

VII. Undetermined

This group includes one sherd, no. 41 (Pl. 7: 41), with a shape that could not be determined due to its small size. It is shaped as a handle or spout, but since the present through-and-through hole has a diameter of only 3–4 mm, the latter seems improbable. Perhaps this hole was used to discharge steam – such holes are known, for example, from baking lids from Veštar (Bekić 2014: 105, no. 1) and Marić Bay (Višnjic et al. 2010: 223, Pl. 6: 10) – or it was a mistake that occurred during the shaping of the vessel.

It is difficult to say whether the vessel was made by hand or on a potter's wheel – the preserved fragment is too small and there are no traces of throwing or smoothing on its surface. The object was fired in a combined atmosphere; the ceramic material is soft – it can be scratched with a fingernail with some difficulty. The dark gray spot on the outer surface may be associated with the use of the vessel on an open hearth.

Preliminary macroscopic assessment of the fabrics

Apart from the five vessels that can be considered as belonging to typical cooking wares of Mediterranean wide distribution (nos. 24, 30–32, 40), the other vessels have a very similar fabric, with the one exception of no. 22. In this case, the frequency of mineral inclusions is lower, 5 – 10%,

and their size is 0.2 – 1.5 mm. Among the mineral inclusions, there are mainly small grains (0.2 – 0.8 mm), elongated and equant, sub-angular and sub-rounded, white, semi-transparent, transparent, grayish, dark gray, with a glassy lustre (most probably quartz); a few bigger grains (1 – 1.5 mm) are elongated and equant, sub-angular and sub-rounded, white, pinkish, transparent; also, there are small mica grains with a platy habit and metallic lustre. The porosity of the fabric is low. The ceramic material is soft – the ceramic surface can be scratched by a fingernail.

In the case of all the other vessels, the fabric is characterized by a significant amount of mineral inclusions, with a minimum frequency of 10 – 15%, and a maximum frequency of 25 – 40%; on average it is 15 – 20%. A polymodal grain size distribution can be observed; the grains are poorly sorted. The size of the macroscopically observed grains is 0.1 – 2 mm in most cases, with the largest grains up to 3 mm long in a few cases (nos. 14–15, 26, 34), and up to 4 mm in rare cases (nos. 1, 12, 41). The most abundant grains are white, semi-transparent, and grayish, equant and elongate, angular (sharp-edged, often with an isometric shape), sub-angular, sub-rounded, numerous, with a platy habit and a glassy lustre (most probably calcite); sparse reddish brown and reddish grains, 0.3 – 1 mm in size, equant and elongate, sub-rounded. The porosity is very low and low sparse pores (0.2 – 1 mm in size) are mostly isometric, rarely elongated.

Only in one case (no. 41), the ceramic material contains not only a significant amount of very coarse mineral inclusions, but also a few imprints and remnants of plants.

Concluding remarks

While coarse cooking wares are very common finds at most Roman and late antique sites (and obviously also at sites from other periods), they present the biggest analytical difficulty, comparable perhaps only to common wares. Firstly, this is due to their merely functional shapes, made with no desire to impress with elaborate morphology or decorations. Therefore, they are quite resistant to changing fashions and remain constant over long periods of time. Only a diachronic regional approach can help construct typo-chronological sequences aimed not only at defining shape-types, but also at linking them with changing social organization and practices, especially when they are regarded in the context of other material culture (e.g. Gelichi 2020: 75–76). Secondly, their fabrics are mostly coarse, which is again an excellent functional feature, but not a very attractive one. Consequently, these materials are seldom considered in a systematic way, resulting in a hiatus in our understanding of the household assemblages of especially the latest periods of antiquity. On the eastern Adriatic in particular, systematic publications or systematizations of stratified late antique coarse ware assemblages are very rare (e.g. Juroš-Mofardin

¹ A detailed analysis of the fabric of this sherd could not be carried out; it will be done during the next field campaign.

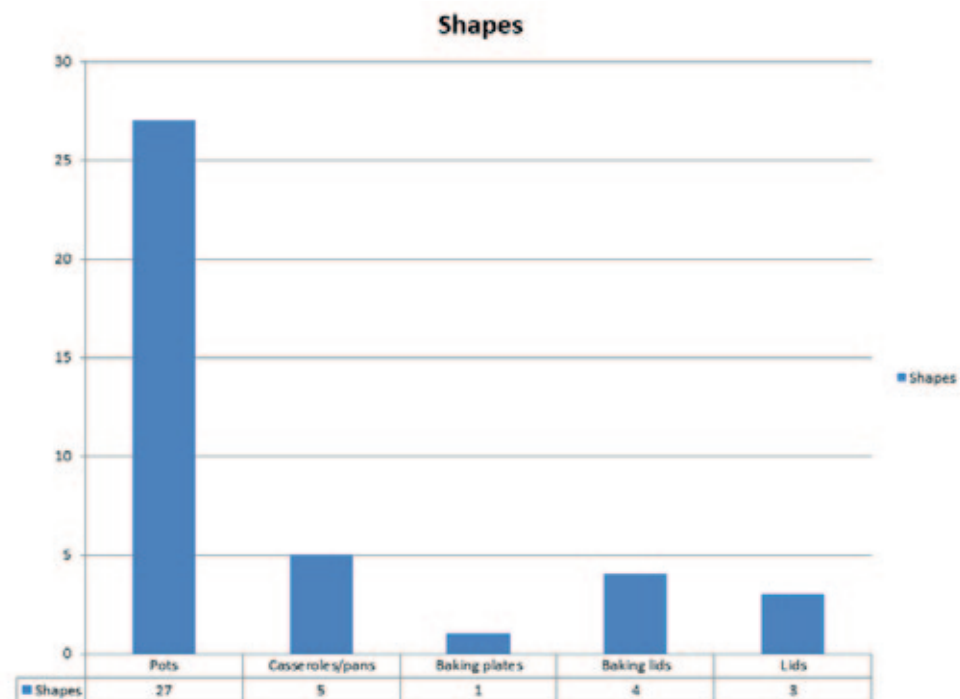

Fig. 3 Quantification of the coarse cooking ware assemblage by shapes (made by: A. Konestra)
 Sl. 3 Kvantifikacija kuhinjskoga posuda prema obliku (izradila: A. Konestra)



Fig. 4 Quantification of the coarse cooking ware assemblage per site (made by: A. Konestra)
 Sl. 4 Kvantifikacija kuhinjskoga posuda prema lokalitetu (izradila: A. Konestra)

1986 and bibliography cited earlier); sometimes, only the most common imported materials were treated more thoroughly (ACW, Aegean CW etc.), while other sherds were often classified simply as “local”.

Since the (late) Roman settlement at Podšilo bay provides a substantial array of cooking wares and stratified contexts, the typology laid out here, though preliminary, does offer an overview of the present types and, thanks to the identified analogies, their possible areas of circulation. Contextually, perhaps the most interesting feature is the infill of a pit at Podkućine, filled with several layers of possibly kitchen refuse. Here, a widespread eastern Mediterranean shape (no. 24, Fulford 35/C.A.T.H.M.A. 5 – mid- 5th century) was found with two specimens of globular pots with grooved walls (nos. 5, 18), along with a Hayes 67 African red slip plate (late 4th – first half of the 5th century, Bonifay 2004: 173) and a LRC/Phocaeen Hayes Form 2-small variant bowl, datable to the 5th c. as well, and the handle of a *spatheion*. Thus, a firmer dating to the 5th century might be put forward for the circulation of types I.2. and I.4. – of course, leaving open the possibility of a longer use of the fine wares. The contexts excavated at Beli Grad so far are still under study, though the association with imported fine wares (dominantly ARS), amphorae, and metal finds (late antique coins, a belt buckle, etc.) again helps circumscribe the dating of the coarse cooking ware within a time-frame ranging from roughly the 5th to the second half of the 6th c.

The assemblage of cooking wares is dominated by pots (Fig. 3), which is typical for late antique sites. There is also a significant number of casseroles, which replaced pans at the end of the 4th and the beginning of the 5th century (Donnelly 2016: 205–215). Another shape that typically occurs in late antique assemblages, after centuries of virtually no evidence, is the baking lid (Vida 2016: 379; Cirelli 2021: 99). Strangely, only a small number of lids has been recovered, which is probably due to chance rather than an actual lack of these objects.

The described shape quantities might be indicative of cooking practices, foodstuff preferences, but also the layout and organisation of the spaces for food preparation. In fact, casseroles, a shape typical of the mid-Roman period, when they were often shaped with a rounded bottom, are usually linked with more solid foods. Also, they necessitated metal stands and were usually used, like the contemporary concave bottom pots, on raised kitchen counters (Riccatò 2020: 190; Cirelli 2021: 98; but cf. Arthur 2007b: 179). Of the identified casseroles, only one example could be considered in phase with the other shapes, while the ACW vessels might be residuals, indicative of cooking practices from previous phases of the site. On the other hand, pots are linked to more liquid foods necessitating longer cooking times, and when there are flat-bottomed pots, use on a hearth might be supposed. The latter is also indicated by the presence of baking lids, another shape which re-enters the ceramic record in late antiquity (Arthur 2007b: 178) and which might have substituted kitchen ovens

for bread baking and for other long-cooking meals (Cirelli 2021: 99). The shapes of cooking ware might also indicate the type of foodstuff used in cooking, and as evidenced by zooarchaeological evidence from several Italian sites, pork and beef are more often related to cooking in pots, while casseroles are present in contexts with ovicaprid bones (Arthur 2007a: 17–19). Since the zooarchaeological data from Podšilo is still awaiting analysis, a conjunction with cooking ware typology will be possible in the future. The shape of both pots and two casseroles – all with flat bottoms – is thus indicative of cooking on an open hearth (Gelichi 2020: Fig. 1), a feature that was identified during the excavations at Beli Grad, and which might indicate not only a change in cooking practices but also in the organisation of cooking spaces, now also used as communal spaces for gathering around a fire (Arthur 2007b: 179).

The vast majority of vessels, except for the obvious Mediterranean imports, are made of a similar fabric, tempered by intentionally crushed calcite or limestone, with a few fine reddish grains.

The closest analogies to the pots from Podšilo bay are vessels from northern Italy, especially from the areas around Ravenna and Aquileia, the (pre-) Alpine region and Slovenia, Istria, the Kvarner Gulf and elsewhere on the eastern Adriatic (Map 1). The best analogies for casseroles with inverted rim can also be found in Italy. In the case of pots, analogies indicate a dating spanning the 4th – 7th centuries, sometimes more precisely the 5th – 6th centuries, but it is difficult to propose more precise dating on these bases because the most numerous types of pots (type I.2, I.3) were in use during a longer time span, sometimes even until the 8th – 9th centuries.

The identified imports from North Africa and the Eastern Mediterranean confirm that the island of Rab in the 4th – 5th century was well included in the networks of the exchange of goods, especially those operating in the northern Adriatic (e.g. Auriemma, Quiri 2007: 54–57; Cirelli 2016; Gelichi et al. 2017; Jelinčić Vučković 2019; Guarnieri 2020), where pottery vessels circulated both regionally and from other parts of the Empire.

At the site level, it would seem that the same typology of vessels can be found both at Podkućine and Beli Grad, though not in the same quantities (Fig. 4),² indicating that the last phases of the (re) use of the site affected different structures, and that daily activities (cooking, eating) might have been occurring in multiple areas of the site. Though more data is needed, perhaps this might point towards an interpretation that sees a (re) occupation of the site by several groups, perhaps families, and is consistent with a type of occupation suggested by the structural evidence too (the postholes) and identified elsewhere on the Adriatic and further west in the timeframe under scrutiny (e.g. Chavarría Arnau 2005: 10–11, 14–17; 2020: 649; Ceglie et al. 2016: 115–116, 125–126).

2 Stratigraphy at Podkućine is much less preserved due to erosion and subsequent dispersion of finds, which might be the reason for fewer recovered materials, along with overall smaller dimensions of the building and of the excavated area.



Map 1 Map with the sites mentioned in the text (made by: B. Nowacki)
 Karta 1 Karta s lokalitetima koji se spominju u tekstu (izradio: B. Nowacki)

Acknowledgments / Remarks

Research on the island of Rab is jointly conducted within the project *Archeological Topography of the Island of Rab* by the Institute of Archaeology of Cardinal Stefan Wyszyński University in Warsaw (UKSW) and the Institute of Archaeology, Zagreb, and is led by F. Welc and A. Konestra. Financing is currently provided by UKSW and the Lopar Culture Centre. This paper stems from the activities carried out within the framework of the grant from the Polish National Science Center (Narodowe Centrum Nauki - NCN): "The fall, crisis or transformation? Correlation of the late antique settlement pattern changes with environment and climate fluctuations in the north-eastern Adriatic region based on results of geoarchaeological and palaeoclimatic research", ID: 478202, NO. 2020/37/B/HS3/02458.

Abbreviations

Kratice

Ostia IV – Ostia IV: le terme del nuotatore, scavo dell'ambiente XVI e dell'area XXV, Carandini A., Panella C. (eds.) 1977, De Luca, Roma.

Bibliography

Literatura

Arthur, P. 2007a, Pots and boundaries. On cultural and economic areas between late antiquity and the early Middle Ages, in: *LRCW 2. Late Roman Coarse Wares, Cooking Wares and Amphorae in the Mediterranean. Archaeology and archaeometry II*, Bonifay M., Trégliat J.-Ch. (eds.), British Archaeological Reports International Series 1662 (II), Archaeopress Publishing Ltd, Oxford, 15–28.

Arthur, P. 2007b, Form, function and technology in pottery production from Late Antiquity to the early Middle Ages, in: *Technology in transition. AD 300–650*, Lavan L., Zanini E., Sarantis A. (eds.), Brill, Leiden – Boston, 159–186.

Aurimemma, R., Quirí, E. 2007, La circolazione delle anfore in Adriatico tra V e VIII sec. d.C., in: *La circolazione delle ceramiche nell'Adriatico tra tarda antichità e altomedioevo. III Incontro di studio Cer.Am.Is.*, Gelichi S., Negrelli C. (eds.), All'Insegna del Giglio, Firenze, 31–64.

Bekić, L. 2009, Gruba antička keramika / Roman coarse pottery, in: *Tarsatički principij – Kasnoantičko vojno zapovjedništvo / Principia at Tarsatica – Late Roman Headquarters*, Bekić L., Radić-Štivić N. (eds.), Grad Rijeka, Rijeka, 99–120.

Bekić, L. 2014, Kasnoantička i ranobizantska keramika s obale Veštra / Spätantike und frühbyzantinische Keramik von der Küste von Veštar, in: *Luka Veštar – Der Hafen von Veštar. Podvodno arheološko istraživanje u uvali Veštar kod Rovinja, Hrvatska, 2008–2014. Unterwasserarchäologische Untersuchungen in der Bucht von Veštar bei Rovinj, Kroatien, 2008–2014*, Bekić L. (ed.), Međunarodni centar za podvodnu arheologiju u Zadru, Zadar, 97–110.

Bekić, L. 2016, *Rani srednji vijek između Panonije i Jadrana. Ranoslavenski keramički i ostali arheološki nalazi od 6. do 8. stoljeća / The Early Medieval Between Pannonia and the Adriatic. Early Slavic Ceramic and Other Archaeological Finds From the Sixth to Eighth Century*, Monografije i katalogi 27, Arheološki muzej Istre, Pula.

Belošević, J. 1992, Ishodi pete, završne kampanje istraživanja lokaliteta Crkvena u selu Galovcu kod Zadra, *Radovi. Razdio povijesnih znanosti*, Vol. 31(18) (1991–1992), 121–142.

Bertoldi, T., Pacetti, F. 2007, Materiali di V secolo dalla Basilica Hilarijana sul Celio: analisi tipologica delle ceramiche comuni, in: *LRCW 3. Late Roman Coarse Wares, Cooking Wares and Amphorae in the Mediterranean. Archaeology and Archaeometry. Comparison between Western and Eastern Mediterranean 2*, British Archaeological Reports International Series 2185 II, Archaeopress Publishing Ltd, Oxford, 433–445.

Bierbrauer, V. 1987, *In villino – Ibligo in Friaul I. Die römische Siedlung und das spätantik-frümmittelalterliche Castrum. Tafeln*, Münchner Beiträge zur Vor- und Frühgeschichte 33, C. H. Beck'sche Verlagsbuchhandlung, München.

Bonifay, M. 2004, *Etudes sur la céramique romaine tardive d'Afrique*, British Archaeological Reports International Series 1301, Archaeopress Publishing Ltd, Oxford.

Brogliolo, G. P., Gelichi, S. 1986, Le ceramiche grezze medievali nella pianura padana, in: *La ceramica medievale nel Mediterraneo Occidentale. Atti del III Congresso internazionale, Siena (8–12 ottobre 1984)*, Faenza (13 ottobre 1984), All'Insegna del Giglio, Firenze, 293–316.

C.A.T.H.M.A. 1991, Importations de céramiques communes méditerranéennes dans le Midi de la Gaule (Ve–VIIe s.), in: *A cerâmica medieval no Mediterrâneo Ocidental. V Congresso Internacional*, Lisboa, 16–22 novembre 1987, s/ed., Campo Arquelógico de Mértola, Mértola, 27–48.

Castagna, D., Spagnol, S. 1996, La ceramica grezza dallo scavo dell'Edificio II di Oderzo: una proposta tipologica, in: *Le ceramiche altomedievali (fine VI – X secolo) in Italia settentrionale: produzione e commerci*, Brogliolo G. P., Gelichi S., SAP Società Archeologica s.r.l., Mantova, 81–94.

Cataldo, M. R. 2012, Aspetti della produzione da fuoco tra tardoantico e altomedioevo: manufatti da Benevento, Rocca san Felice e Montella, in: *Atti del IX Congresso Internazionale sulla Ceramica Medievale nel Mediterraneo*, Gelichi S. (ed.), All'Insegna del Giglio, Firenze, 509–511.

Cavalazzi, E., Fabbri, E. 2010, Cooking ware from the excavation of a 5th–7th century context in Classe (Ravenna, Italy), in: *LRCW 3. Late Roman Coarse Wares, Cooking Wares and Amphorae in the Mediterranean. Archaeology and Archaeometry. Comparison between Western and Eastern Mediterranean 2*, Menchelli S., Santoro S., Pasquinucci M., Guiducci G. (eds.), British Archaeological Reports International Series 2185 II, Archaeopress Publishing Ltd, Oxford, 623–633.

Ceglia, V., Marchetta, I., La Fratta, I. 2016, Occupazione e rioccupazione: lettura del fenomeno nelle ville tardoantiche molisane tra V e VIII secolo, in: *Territorio, insediamenti e necropoli fra tarda antichità e Alto Medioevo. Atti del Convegno internazionale di studi Territorio e insediamenti fra tarda antichità e Alto Medioevo, Cimitile-Santa Maria Capua Vetere, 13–14 giugno 2013; Atti del Convegno internazionale di studi Luoghi di culto, necropoli e prassi funeraria fra tarda antichità e Medioevo, Cimitile-Santa Maria Capua Vetere, 19–20 giugno 2014*, Ebanista C., Rotili M. (eds.), Giornate sulla tarda antichità e il Medioevo 7, Rogiosi Editore, Napoli, 115–130.

Cirelli, E. 2016, Il ruolo delle città portuali nelle dinamiche del commercio tra Adriatico e Ionio nell'alto Medioevo (V–IX sec.), *Hortus Artium Medievalium*, Vol. 22, 33–43.

Cirelli, E. 2021, *Archeologia e cultura materiale nel medioevo*, Bononia University Press, Bologna.

Cirelli, E., Cannavici, A. 2014, A 6th century dump from Classe (Ravenna), in: *LRCW 4. Late Roman Coarse Wares, Cooking Wares and Amphorae in the Mediterranean. The Mediterranean: a market without frontiers*, Poulou-Papadimitriou N., Nodarou E., Kilikoglou V. (eds.), British Archaeological Reports International series 2616, Archaeopress Publishing Ltd, Oxford, 963–974.

Chavarría Arnau, A. 2005, Considerazioni sulla fine delle ville in occidente, *Archeologia Medievale*, Vol. XXXI, 7–19.

Chavarría Arnau, A. 2020, The Fate of Late-Roman Villas in Southern Gaul Between the Sixth and Seventh Centuries, in: *The Oxford Handbook of the Merovingian World*, Effros B., Moreira I. (eds.), Oxford University Press, Oxford, 641–656.

Corti, C. 2001, Le ceramiche comuni: ceramiche d'impasto grezzo, in: *L'insediamento preistorico e Romano di Corte Vanina (località Fossa di Concordia). Nuove ricerche archeologiche nella Bassa Modenese*, Calzolari M., Giordani N. (eds.), Gruppo studi Bassa Modenese, Modena, 120–140.

Corti, C. 2007, La frequentazione nell'area di S. Maria in Padovetere: materiali dalla chiesa e dall'insediamento circostante, in: *Genti nel Delta da Spina a Comacchio. Uomini, territorio e culto dall'antichità all'alto medioevo*, Berti F., Bollini M., Gelichi S., Ortalli J. (eds.), Corbo, Ferrara, 569–589.

Corti, C., Loschi Ghittoni, A. G. 2007, Produzioni di ceramiche ad impasto grezzo nelle aree del medio e basso corso del Po tra tardoantico e altomedioevo: la bassa pianura modenese e l'antico delta Padano, in: *LRCW 2. Late Roman Coarse Wares, Cooking Wares and Amphorae in the Mediterranean. Archaeology and archaeometry II*, Bonifay M., Trégliat J.-Ch. (eds.), British Archaeological Reports International Series 1662 (II), Archaeopress Publishing Ltd, Oxford, 511–524.

Cubberley, A. L., Lloyd, J. A., Roberts, P. C. 1988, Testa and Clibani: The Baking Covers of Classical Italy, *Papers of the British School at Rome*, Vol. 56, 98–119.

Cunja, R. 1996, *Poznorimski in zgodnesrednjeveški Koper. Arheološko izkopavanje na bivšem Kapucinskem vrtu v letih 1986–1987 v luči drobnih najdb 5. do 9. stoletja / Capodistria Tardoromana e Altomedievale. Lo scavo archeologico nell'ex orto dei Cappuccini negli anni 1986–1987 alla luce dei reperti dal V al IX secolo D.C.*, Zgodovinsko društvo za južno Primorsko, Znanstvenoraziskovalno središče Koper, Pokrajinski muzej Koper, Koper.

Čondić, N., Vuković, M. 2017, *U temeljima grada. Iz arheoloških slojeva liburnskoga Zadra*, Katalogi i monografije 27, Arheološki muzej Zadar, Zadar.

Donnelly, A. 2016, *Cooking, Cooking Pots, and Cultural Transformation in Imperial and Late Antique Italy*, Unpublished PhD Thesis, Loyola University Chicago, Chicago. https://ecommons.luc.edu/luc_diss/2279

- Fentress, E. 2010 Cooking pots and cooking practice: an African bain-marie?, *Papers of the British School at Rome*, Vol. 78, 145–150.
- Fulford, M. G. 1984, The Coarse (Kitchen and Domestic) and Painted Wares, in: *Excavations at Carthage: the British mission Vol. 1, 2. The Avenue du President Habib Bourguiba, Salammbô: The Pottery and Other Ceramic Objects from the Site*, Peacock D. P. S., Fulford M. G. (eds.), University of Sheffield, Sheffield, 155–231.
- Gelichi, S. 1983, Ceramica grezza altomedievale, in: *Ravenna e il porto di Classe. Venti anni di ricerche archeologiche tra Ravenna e Classe*, Bermond Montanari G. (ed.), Salerno, Bologna, 127–129.
- Gelichi, S. 1998, Ceramiche 'tipo Classe', in: *Ceramica in Italia: VI-VII secolo, Atti del Convegno in onore di John W. Hayes, Roma 11-13 maggio 1995*, Saggi L. (ed.), Biblioteca di Archeologia medievale 14, All'Insegna del Giglio, Firenze, 481–485.
- Gelichi, S. 2020, Pottery as Inequality?: Systems of Production and Distribution, in: *North Italian Societies During the Early Middle Ages. Social Inequality in Early Medieval Europe: Local Societies and Beyond*, Quirós Castillo J. A. (ed.), Haut Moyen Âge 39, Brepols, Turnhout, 75–97.
- Gelichi, S., Negrelli, C., Ferri, M., Cadamuro, S., Cianciosi, A., Grandi, E. 2017, Importare, produrre e consumare nella laguna di Venezia dal IV al XII secolo. Anfore, vetri e ceramiche, in: *Adriatico altomedievale (VI-XI secolo). Scambi, porti, produzioni*, Gelichi S., Negrelli C. (eds.), Studi e Ricerche 4, Edizioni Ca' Foscari, Venezia, 23–114. <https://doi.org/10.14277/6969-115-7/SR-4-1>
- Guarnieri, C. 2020, Ravenna, Classe and its Surroundings: Pottery as a Mirror of Everyday Life, in: *Ravenna and the Traditions of Late Antique and Early Byzantine Craftsmanship*, Cosentino S. (ed.), De Gruyter, Berlin, 259–292. <https://doi.org/10.1515/9783110684346-010>
- Hayes, J. W. 1972, *Late Roman Pottery*, British School at Rome, London.
- Jelinčić Vučković, K. 2015, *Rimsko selo u provinciji Gornjoj Panoniji: Virovitica Kiškorijska jug / Roman Village in the Province of Upper Pannonia: Virovitica Kiškorijska South*, Monografiae Instituti Archaeologici 7, Institute of Archaeology, Zagreb.
- Jelinčić Vučković, K. 2019, Le importazioni africane trovate sull'isola di Brač/Brattia, Dalmazia, in: *Economia e Territorio. L'Adriatico centrale tra tarda Antichità e alto Medioevo*, Cirelli E., Giorgi E., Lepore G. (eds.), British Archaeological Reports International series 2926, Archaeopress Publishing Ltd, Oxford, 525–534.
- Jurković, M., Turković, T. 2019, Kaštelina – vila obitelji Bebija, *Ars Adriatica*, Vol. 9, 7–20.
- Juroš-Mofardin, F. 1986, Pokušaj sistematizacije kasnoantičke i ranobizantske keramike grube fakture iz profanog objekta u Betigi kod Barbarige, in: *Arheološka istraživanja u Istri i Hrvatskom primorju*, Znanstveni skup, Pula, 15.–18. rujna 1982, Girardi Jurkić V. (ed.), Izdanja Hrvatskog arheološkog društva 11(2), Hrvatsko arheološko društvo, Zagreb, 209–233.
- Knific, T. 1994, Vranje near Sevnica: A Late Roman Settlement in the Light of Certain Pottery Finds, *Arheološki vestnik*, Vol. 45, 211–237.
- Konestra, A., Welc, F., Dugonjić, A., Androić Gračanin, P., Rabiega, K., Solceky, R., Nowacki, B. 2019, Istraživanja projekta „Arheološka topografija otoka Raba“ u 2018. godini na području Lopara: nova saznanja o prapovijesnim i kasnoantičkim lokalitetima / Research within the "Archaeological topography of the Island of Rab" project at Lopar in 2018: new data on Prehistoric and late Antique sites, *Annales Instituti Archaeologici*, Vol. XV, 187–194.
- Konestra, A., Welc, F., Androić Gračanin, P., Rabiega, K., Nowacki, B., Kukela, A. 2020, Tipologija i organizacija otočnih naselja Raba kroz dijakronijski pristup – Prvi podaci multidisciplinarnih istraživanja / Rab island settlement typology and organisation through a diachronic approach – First data from a multidisciplinary research, *Annales Instituti Archaeologici*, Vol. XVI, 229–244.
- Konestra, A., Androić Gračanin, P., Welc, F. 2021a, Burialscapes of Rab Island (North East Adriatic): The Role of Sepulchral Evidence in the Reconstruction of Roman and Late Antique Rural Settlement Pattern, *Annales, Series Historia et Sociologia*, Vol. 31(3), 391–412.
- Konestra, A., Welc, F., Androić Gračanin, P. 2021b, Lokalitet na rtu Zidine u Loparu u kontekstu obalnih rezidencijalno-gospodarskih kompleksa otoka Raba / The site at the cape Zidine in Lopar in the context of coastal residential and commercial complexes of Rab Island, *Annales Instituti Archaeologici*, Vol. XVII, 152–170.
- Lavazza, A., Vitali, M. G. 1994, La ceramica d'uso comune: problemi generali e note su alcune produzioni tardoantiche e medievali, in: *Ad Mensam. Manufatti d'uso da contesti archeologici fra tarda antichità e medioevo*, Lusuardi Siena S. (ed.), Del Bianco Editore, Udine, 17–54.
- Lipovac Vrkljan, G., Šiljeg, B. 2010, Lopar-Podšilo, zaštitno arheološko istraživanje rimske keramičarske peći 2009. / Lopar-Podšilo, Archaeological Rescue Excavation of a Roman Kiln in 2009, *Annales Instituti Archaeologici*, Vol. VI, 64–69.
- Lipovac Vrkljan, G., Konestra, A., Šegvić, N. 2017, Felix Arba – reconstructing urban and rural economic capacities through GIS, in: *Mapping urban changes / Mapiranje urbanih promjena*, Plosnić Škarić A. (ed.), Institute of Art History, Zagreb, 314–335.
- Mardešić, J., Šalov, T. 2002, Keramički nalazi s istraživanja bazilike u Ereševim barama – Vid kod Metkovića, *Vjesnik za arheologiju i historiju dalmatinsku*, Vol. 94, 105–163.
- Marušić, B. 1986a, Materijalna kultura Istre od 5. do 9. stoljeća, in: *Arheološka istraživanja u Istri i Hrvatskom primorju*, Znanstveni skup Pula, 15 – 18. rujna 1982., Jurkić V. (ed.), Izdanja Hrvatskog arheološkog društva 11(1), Hrvatsko arheološko društvo, Arheološki muzej Istre, Povijesno društvo Istre, Zagreb, 81–105.
- Marušić, B. 1986b, Prilog poznavanja kasnoantičkog Nezakcija, *Starohrvatska prosvjeta*, Vol. 16, 51–76.
- Mihovilić, K. 2014, *Histri u Istri. Željezno doba Istre*, Monografije i katalogi 23, Arheološki muzej Istre, Pula.
- Modrijan, Z. 2010, The last phases of the settlement at Tonovcov grad (Slovenia): the ceramic evidence, in: *LRCW 3. Late Roman Coarse Wares, Cooking Wares and Amphorae in the Mediterranean: Archaeology and Archaeometry. Comparison between Western and Eastern Mediterranean 2*, Menchelli S., Santoro S., Pasquinucci M., Guiducci G. (eds.), British Archaeological Reports International Series 2185 (II), Archaeopress Publishing Ltd, Oxfors, 687–694.
- Modrijan, Z., Milavec, T. 2011, *Poznoantična utrjena naselbina Tonovcov grad pri Kobaridu. Najdbe / Late antique fortified settlement Tonovcov grad near Kobarid. Finds*, Opera Instituti Archaeologici Sloveniae 24, Institut za arheologijo ZRC SAZU, Založba ZRC, Ljubljana.
- Modrijan, Z. 2020, Pottery from the Late Roman hilltop settlement at Ančnikovo gradišče (Slovenia), *Rei Cretariae Romanae Favtorum Acta*, Vol. 46, 317–326.
- Negrelli, C. 2015, Dal VI all'VIII secolo: continuità e rotture nella circolazione dei manufatti ceramici tra Romagna e Delta padano, in: *Le forme della crisi. Produzioni ceramiche e commerci nell'Italia centrale tra Romani e Longobardi (III – VIII sec. d.C.)*, Atti del Convegno, Spoleto – Campello sul Clitunno, 5-7 Ottobre 2012, Cirelli E., Diosono F., Patterson H. (eds.), Ante Quem, Bologna, 139–152.
- Negrelli, C. 2021, Le ceramiche tardoantiche e altomedievali, in: *Un emporio e la sua cattedrale. Gli scavi di piazza XX Settembre e Villaggio San Francesco a Comacchio*, Gelichi S., Negrelli C., Grandi E. (eds.), All'Insegna del Giglio, Firenze, 201–276.
- Ožanić Roguljić, I. 2018, Instrumentum domesticum na lokalitetu Banjače, *Opuscula archaeologica*, Vol. 39–40, 151–203.
- Pešić, M. 2019, *Afrički import iz hrvatskog podmorja od I. do V. stoljeća*, Unpublished PhD Thesis, University of Zadar, Zadar.
- Riccato, A. 2020, *Aquileia. Fondi Cossar. 3.2. La ceramica da cucina: produzioni italiane e orientali, Scavi di Aquileia I, Scavi di Aquileia II*, Quasar, Roma.
- Rodriguez, H. 1997, Die Zeit vor und nach der Schlacht am Fluvius Frigidus (394) im Spiegel der sudostalpinen Gebrauchskeramik, *Arheološki vestnik*, Vol. 48, 153–178.
- Ruffieux, P. 2010, Céramique commune de l'antiquité tardive découverte sur le site de l'église Sainte-Cécile a Guran, en Istrie, *Hortus Artium Medievallium*, Vol. 16, 247–266.
- Sbarra, F. 2014, I materiali ceramici: la ceramica grezza e la ceramica invetriata, in: *Un villaggio nella pianura. Ricerche archeologiche in un insediamento medievale del territorio di Sant'Agata Bolognese*, Gelichi S., Librenti M., Marchesini M. (eds.), All'Insegna del Giglio, Firenze, 146–178.
- Shkodra, B. 2006, Ceramics from Late Roman Contexts in Durrës, *The Annual of the British School at Athens*, Vol. 101, 427–457.
- Topić, M. 2004, Keramika iz Augusteuma Narone, *Vjesnik za arheologiju i historiju dalmatinsku*, Vol. 97, 69–93.
- Turnovsky, P. 2005, The Morphological Repertory of Late Roman/Early Byzantine Coarse Wares in Ephesos, in: *LRCW 1. Late Roman Coarse Wares, Cooking Wares and Amphorae in the Mediterranean. Archaeology and Archaeometry*, Gurt i Esparraguera J. M^a, Buxeda i Garrigós J., Cau Ontiveros M. A (eds.), British Archaeological Reports International Series 1340, Archaeopress Publishing Ltd, Oxford, 636–646.
- Vida, T. 2016, Backglocken, Backdeckel und Backhauben. Archäologische Angaben zur Ernährungskultur Süd- und Mitteleuropas, *Acta Archaeologica*, Vol. 67, 361–421.
- Višnjić, J., Bekić, L., Pleština, I. 2010, Arheološka istraživanja na prostoru antičke uljare u uvallu Marić (Porto Marrić) kod Barbarige. Ranocarski gospodarski kompleks – utočiste kasnoantičkog stanovništva, *Portal*, Vol. 1, 201–232.
- Vrančić, N., Jančič, A. 2020, Razvoj utvrde Lopar u Novom Vinodolskom kroz pokretne nalaze / Development of Fort Lopar in Novi Vinodolski through movable finds, *Starohrvatska prosvjeta*, Vol. III(47), 119–230.
- Waksman, S. Y., Tréglia, J.-C. 2007, Caractérisation géochimique et diffusion méditerranéenne des céramiques culinaires « égéennes ». Etudes comparées des mobiliers de Marseille, de Beyrouth et d'Alexandrie (Ve-VIII s.), in: *LRCW 2. Late Roman Coarse Wares, Cooking Wares and Amphorae in the Mediterranean. Archaeology and Archaeometry 2*, Bonifay M., Tréglia J.-C. (eds.), British Archaeological Reports International Series 1662(II), Archaeopress Publishing Ltd, Oxford, 645–657.

Warner Slanc, K., Kiriatzi, E. 2014, Kythera al fresco: middle and late Roman cooking pots from the Aegean region, in: *LRCW4. Late Roman Coarse Wares, Cooking Wares and Amphorae in the Mediterranean. Archaeology and Archaeometry. The Mediterranean: a market without frontiers*, Poulou-Papadimitriou N., Nodarou E., Kilikoglou V. (eds.), British Archaeological Reports International Series 2616, Archaeopress Publishing Ltd, Oxford, 907–918.

Welc, F. 2018, Geoarchaeology of pottery workshop sites in Roman Dalmatia, in: *Pottery production, landscape and economy of Roman Dalmatia. Interdisciplinary approaches*, Lipovac Vrkljan G., Konestra A. (eds.), Archaeopress Publishing Ltd, Oxford, 62–70.

Welc, F., Mieszkowski, R., Lipovac Vrkljan, G., Konestra, A. 2017, An Attempt to Integration of Different Geophysical Methods (Magnetic, GPR and ERT). A Case Study From the Late Roman Settlement On the Island of Rab in Croatia, *Studia Quaternaria*, Vol. 34(1), 47–59.

Welc, F., Konestra, A., Dugonjić, A., Androić Gračanin, P., Rabić, K., Nowacki, B. 2019, Multidisciplinary insight into late Roman rural settlement on the northeastern Adriatic coast of Croatia: Island of Rab case study, *Polish Archaeology in the Mediterranean*, Vol. 28(2), 481–508.

Sažetak

Prema rezultatima recentnih multidisciplinarnih istraživanja (posljednje u Konestra et al. 2020; Welc et al. 2019) ruralni su krajolici otoka Raba u antici bili karakterizirani brojnim gospodarsko-stambenim kompleksima (uvjetno vilama) koji su se smjestili kako unutar njegovih plodnih polja tako i uz obalu. Od 2016. godine istraživanja se provode na jednom takvom lokalitetu, u uvali Podšilo, na poluotoku Loparu u sjevernom dijelu otoka. Zahvaljujući geoarheološkim istraživanjima i iskapanjima manjega opsega, bilo je moguće locirati i definirati dva arhitektonska sklopa smještena u zaleđu uvale na područjima lokalno poznatima kao Podkućine i Beli Grad. Objekt u Podkućinama mogao bi se definirati kao utilitarni objekt (skladišni ili gospodarski sklop), a veći i raščlanjeniji kompleks na Belom Gradu mogao bi se identificirati kao središnji stambeni i proizvodni objekt naselja (Konestra et al. 2019; 2020). Stratigrafija obaju kompleksa upućuje na višefazno korištenje od ranije pa sve do u kasnu antiku.

Unutar kasnih slojeva, uvjetno datiranih u 5.–6. stoljeće, pronađena je raznolika skupina gruboga kuhinjskoga posuda te je definiran minimalni broj posuda (41). Ti su nalazi omogućili deiniciju preliminarnu tipologije koja može pomoći u preciznijem datiranju posljednje faze naseljavanja, utvrđivanju kućanskih aktivnosti i kuhinjskih navika te određivanju regionalne povezanosti i obrazaca razmjene. Obrada keramičkoga posuda uključila je analizu morfologije

i funkcije posuda te detaljnu makroskopsku analizu keramičkih struktura. Materijal je podijeljen prema funkcionalnim oblicima: lonci i dna, kaserole/tave, pekači, peke, poklopci i oblici nejasne definicije.

Loncima pripada 27 posuda (24 oboda i tri dna) koje čine gotovo 66 % posuda, što je tipično za kasnoantičke lokalitete. Može se pretpostaviti da je većina lonaca imala ravno dno. 12 posuda iz ove skupine ima urezani ukras ili obradu površine, najčešće (sedam posuda) u obliku tankih, horizontalnih, paralelnih žljebova na ramenu. Dvije posude imaju valovitu traku (više linija) male amplitude i velikoga odstupanja, urezanu na ramenu pomoću predmeta s više vrhova (češalj?). Dvije posude na ramenu imaju ukras u obliku dvaju valovitih traka. U većini slučajeva posude su oblikovane na lončarskom kolu, a pečene su u različitim uvjetima – najčešće u redukcijskoj atmosferi.

Važnu skupinu čine kaserole/tave koje su krajem 4. – početkom 5. stoljeća zamijenile niske tave antičke tradicije. Zajedno s oblicima regionalne rasprostranjenosti koje karakterizira uvijeni rub prisutni su i importi iz sjevernoafričkih radionica (možda kao rezidualni nalazi?) (Hayes 23B – Culinaire type 1, Hayes form 197 – Culinaire type 10 te možda Late Roman Cooking pot 1) (Hayes 1972; Bonifay 2004).

Osim posuda zatvorenoga oblika izdvajaju se pladanj za pečenje, tzv. pekač, i ulomci peka, koje su također tipične u kasnoantičkoj kuhinjskoj keramici. Dosad su izdvojena samo tri ulomka poklopaca. Dva su poklopca s pravilnim, konkavnim i izvana zadebljanim rubom, dok je treći sa zadebljanim rubom i promjerom od 34 cm te pripada afričkom kuhinjskom posudu, tipu Hayes 196 – Culinaire C/A type 11.

Velika većina posuda, osim očitoga mediteranskog importa, izrađena je od slične keramičke strukture s namjerno dodanim drobljenim kalcitom ili vapnencem, a unutar koje su makroskopskom analizom razlučiva i sitna crvenkasta zrnca. Poroznost je niska ili vrlo niska, a keramički materijal je uglavnom tvrd.

Oblik lonaca i dviju kaserola – sve s ravnim dnom – ukazuje na kuhanje na otvorenom ognjištu, što bi mogao potvrditi i nalaz manjeg ognjišta u sklopu istraživanja na položaju Beli Grad, a koje bi moglo upućivati ne samo na promjenu u načinu kuhanja u odnosu na ranija antička razdoblja, već i u organizaciji kuhinjskih prostora, koji se sada koriste i kao zajednički prostori okupljanja oko vatre.

Najbliže analogije loncima iz uvale Podšilo su posude iz sjeverne Italije, posebice s područja oko Ravene i Akvileje, (pred)alpskog područja te Slovenije, Istre i Kvarnerskog zaljeva (npr. Bierbrauer 1987; Cunja 1996; Ruffieux 2010; Modrijan, Milavec 2011; Riccato 2020 i dr.). Lonac n. 24 pripada pak importu s istočnoga Mediterana (*Ephesos Gray Ware*) (Fulford 35 / C.A.T.H.M.A. 5, Fulford 1984: 187–189, Fig. 70; C.A.T.H.M.A. 1991: 35, Fig. 17). Najbolje analogije za kaserole s uvijenim rubom mogu se također pronaći u Italiji (npr. Cavalazzi, Fabbri 2010: 627, Pl. 1: 1–4, Cirelli, Cannavici 2014: 974, Fig. 10: 8–9 i dr.). U slučaju lonaca analogije upućuju na dataciju u rasponu od 4. do 7. stoljeća, ponekad preciznije u razdoblje 5.–6. stoljeće,

ali je na tim osnovama teško predložiti precizniju dataciju jer su najbrojniji tipovi lonaca (tip I.2. , I.3) bili su u uporabi kroz dulje razdoblje, koje ponekad uključuje i 8. – 9. stoljeće.

Identificirani importi iz sjeverne Afrike i s istočnoga Sredozemlja potvrđuju da je u 4. – 5. stoljeću otok Rab bio uključen u raširene mreže razmjene, posebice one aktivne na sjevernom Jadranu, gdje cirkuliraju keramika sudaljenih područja te ona regionalne proizvodnje.

Zahvale / Napomene

Istraživanja otoka Raba zajednički provode Institut za arheologiju Sveučilišta Cardinal Stefan Wyszyński u Varšavi (UKSW) i Institut za arheologiju, Zagreb, u sklopu projekta Arheološka topografija otoka Raba, a vode ih F. Welc i A. Konestra. Sredstva trenutno osiguravaju UKSW i Centar za kulturu Lopar. Ovaj rad proizlazi iz aktivnosti provedenih u okviru stipendije Poljskog nacionalnog znanstvenog centra (Narodowe Centrum Nauki – NCN): „Pad, kriza ili transformacija? Korelacija promjena kasnoantičkog obrasca naseljavanja s okolišem i klimatskim fluktuacijama u regiji sjeveroistočnog Jadrana na temelju rezultata geoarheoloških i paleoklimatskih istraživanja“, ID: 478202, NO. 2020/37/B/HS3/02458.

No. / Broj	Plate no. / Tabla broj	Vessel / Posuda	Form / Oblik	Type / Tip	Morphology and decoration / Morfologija i ukras	Fabric description / Opis struktura	Analogies / Analogije
1	1: 1	BG S2 SJ92 N127/1	pots	I.1. Pots with thick vertical or everted rim and sharp internal break towards the body	Dimensions – Rd – 14.2 cm, Wt – 0.9 – 1.1 cm, pH – 3.2 cm Hardness – hard Decoration/surface treatment – ragged and unsmoothed, without decorations	Mineral inclusions – Type: polimodal grain size distribution; the coarser white or semi-transparent grains are 0.5–4 mm in size, elongated and equant, angular and sub-angular, with an isometric shape, a platy habit and a glassy lustre. Most probably calcite; the finer grains are white, greyish or semi-transparent, 0.2–0.5 mm in size, mostly equant, angular and sub-angular. Size: 0.2–4 mm. Frequency: 15–25%. Porosity – very/low	CROATIA Guran, Istria Ruffeux 2010: 259, Pl. 1 – type I. B.? CROATIA Galovac, Crkвина Belošević 1992: Pl. XLVII: 2 – medieval pot
2	1: 2	BG S2 SJ90 N130/2	pots	I.1. Pots with thick vertical or everted rim and sharp internal break towards the body	Dimensions – Wt. 0.9–1.5 cm; pH – 3.5 cm Hardness – hard Decoration/surface treatment – ragged and unsmoothed, and without decorations	Mineral inclusions – Type: polimodal grain size distribution, grains poorly sorted, abundant white, semi-transparent and grayish, angular, elongated and equant grains, 0.5–2.5 mm in size, numerous with a platy habit and a glassy lustre (most probably calcite); sparse reddish brown and reddish grains, which are 0.3–1 mm in size. Size: 0.1–2.5 mm. Frequency: 10–15%. Porosity – very/low	ITALY Ravenna, Classe Cavalazzi, Fabbri 2010: 630, Fig. 4: 12
3	1: 3	PK S2 SJ47 N39/1	pots	I.1. Pots with thick vertical or everted rim and sharp internal break towards the body	Dimensions – Rd – 18.0 cm, Wt – 0.6–1.1 cm, pH – 3.2 cm Hardness – hard Decoration/surface treatment – incised decoration: horizontal, parallel grooves on the rim and shoulder on the inner and on the outer surface	Mineral inclusions – Type: polimodal grains size distribution; the most abundant grains are white, semi-transparent, grayish, angular – sub-rounded, equant – elongate, 0.1–2.5 mm in size, some grains with a platy habit and a glassy lustre (probably calcite); some bigger grains (1–1.5 mm in size) are pale brown and mat; abundant fine grains fraction (0.1–0.5 mm in size), grains are gray, dark gray, equant, sub-rounded. Size: 0.1–2.5 mm. Frequency: 15–20%. Porosity – low	CROATIA Veštar Bekić 2014: 106, no. 22 CROATIA Principia in Rijeka Bekić 2009: Pl. 6: 11? ITALY Aquileia Fondi Cossar Riccatto 2020: 215, Pl. XXI: 3 – olle tipi 34,3 ITALY Cesena, Colle Garampo Negrelli 2015: 147, Pl. 4: 8 – olle ITALY Sant'Agata Bolognese Sbarra 2014: 155, Pl. 3: 1 – pots type 3
4	1: 4	BG S2 SJ99 N132/4	pots	I.2. Pots with globular body and everted rim with square profile	Dimensions – Rd – 21.8 cm, Wt – 0.8 cm, pH – 2.5 cm Hardness – hard Decoration/surface treatment – outer surface smoothed	Mineral inclusions – Type: polimodal grain size distribution; grey, semi-transparent and whitish big grains, which are 0.5–2 mm in size, equant and elongate, angular with sharp edges and sub-angular grains, some grains have an isometric shape, a platy habit and a glassy lustre (calcite?); abundant medium-sized grains fraction, which are 0.2–0.5 mm in size, equant and elongate, angular with sharp edges and sub-angular with a glassy lustre; abundant very fine grain fraction (0.1–0.2 mm), grains greyish, semi-transparent and whitish, sub-angular and sub-rounded. Size: 0.1–2 mm. Frequency: 25–40%. Porosity – very/low.	ITALY Aquileia, Fondi Cossar Riccatto 2020: 214, Pl. XX: 8 – pots type 34,2
5	1: 5	PK S1 SJ126 PN-13	pots	I.2. Pots with globular body and everted rim with square profile	Dimensions – Rd – 18.8 cm, Wt – 0.5 – 0.9 cm, pH – 7.0 cm Hardness – hard Decoration/surface treatment – on the inner surface parallel and delicately defined wheel throwing marks, on the outer surface, on upper shoulder horizontal, parallel lines, below: horizontal, parallel grooves	Mineral inclusions – Type: polimodal grain size distribution; the most abundant grains are white, semi-transparent and grayish, very angular – sub-rounded, equant – elongate, 0.2–1.5 mm in size, with a platy habit and a glassy lustre (most probably calcite). Size: 0.2–1.5 mm. Frequency: 15–20%. Porosity – very/low, not very numerous pores, 0.5–1 mm in size, mainly isometric	SLOVENIA Tonovcov grad Modrijan, Milavec 2011: 540, Pl. 90: 3, 5, 7 – pots type 2 ITALY Aquileia Fondi Cossar Riccatto 2020: 219, Pl. XXV: 2–6 – pots type 37 Profile: Riccatto 2020: 215, Pl. XXI: 5 – pots type 34,3

No. / Broj	Plate no. / Tabla broj	Vessel / Posuda	Form / Oblik	Type / Tip	Morphology and decoration / Morfologija i ukras	Fabric description / Opis strukture	Analogies / Analogije
6	1: 6	BG-S1 SJ5 N371	pots	I.2. Pots with globular body and everted rim with square profile	Dimensions – Rd – 14,2 cm, Wt – 0.5 cm, pH – 3.1 cm Hardness – hard Decoration/surface treatment – on the inner surface horizontal, parallel lines	Mineral inclusions – Type: polymodal grain size distribution; the most abundant grains are white, semi-transparent and greyish, very angular (intentionally crushed) – sub-rounded, equant – elongate, 0.1–2.5 mm in size, with a platy habit and a glassy lustre (most probably calcite); brown and dark brown shiny grains, which are 0.3–0.8 mm in size, equant and sub-rounded; reddish grains, which are 0.2–0.5 mm in size, equant and sub-rounded. Size: 0.1–2.5 mm. Frequency: 15–20%. Porosity – very low, sparse pores (0.2–1 mm in size), mostly isometric, some elongated	CROATIA Guran, Istria Ruffieux 2010: 260, Pl. 2 – type I.F. ITALY Aquileia, Fondi Cossar Riccatò 2020: 199, Pl. V – pots type 3 ITALY Ravenna, Classe Brogiolo, Gelichi 1986: 297, Pl. II: 2 ITALY S. Maria in Pado Vetere Corti 2007: 583, Fig. 12: 5
7	1: 7	BG-S2 SJ72 N126/2	pots	I.2. Pots with globular body and everted rim with square profile	Dimensions – Rd – 19 cm, Wt – 0.6 cm, pH – 4, 6 cm Hardness – hard Decoration/surface treatment – on the inner surface under the rim horizontal and diagonal multiple lines/grooves, carved with a multi-point tool	Mineral inclusions – Type: polymodal grain size distribution; the most abundant grains are white, semi-transparent and greyish, very angular – sub-rounded, mostly equant – few elongate, 0.1–1.5 mm in size, with a platy habit and a glassy lustre (most probably calcite), very numerous very small white grains (0.1–0.2 mm in size); few brownish gray and dark gray grains, angular – sub-rounded, equant 0.3–0.8 mm in size; sparse reddish brown and reddish grains, which are 0.2–0.5 mm in size, equant, sub-angular – sub-rounded. Size: 0.1–1.5 mm. Frequency: 15–20%. Porosity – very low, sparse pores (0.2–1 mm in size), mostly isometric, some elongated	CROATIA Guran, Istria Ruffieux 2010: 260, Pl. 2 – type I.F. ITALY Ravenna, Classe Brogiolo, Gelichi 1986: 297, Pl. II: 1–4 ITALY Aquileia, Fondi Cossar Riccatò 2020: 216, Pl. XXII: 2 – pots type 34, 3
8	2: 8	BG-S2 SJ42 N99	pots	I.2. Pots with globular body and everted rim with square profile	Dimensions – Rd – 17 cm, Wt – 0.7 cm, pH – 4, 6 cm Hardness – hard Decoration/surface treatment – horizontal, parallel lines/grooves on the inner surface under the rim	Mineral inclusions – Type: polymodal grain size distribution; the most abundant grains are white, semi-transparent and greyish, very angular – sub-rounded, mostly equant – few elongate, 0.1–1.5 mm in size, with a platy habit and a glassy lustre (most probably calcite), very numerous very small white grains (0.1–0.2 mm in size); few brownish gray and dark gray grains, angular – sub-rounded, equant 0.3–0.8 mm in size; sparse reddish brown and reddish grains, which are 0.2–0.5 mm in size, equant, sub-angular – sub-rounded. Size: 0.1–1.5 mm. Frequency: 15–20%. Porosity – very low, sparse pores (0.2–1 mm in size), mostly isometric, some elongated	CROATIA Guran, Istria Ruffieux 2010: 259, Pl. 1: 9 – pots type I.D. CROATIA Lopar Novi Vinodolski Vrančić, Janeš 2020: 181, Pl. 1: 1–5 – pots type Ia CROATIA Banijače Ožanić Roguljić 2018: 191, Pl. 4: 46 CROATIA Principia in Rijeka Bekić 2009: Pl. 6: 7
9	2: 9	BG-S2 SJ72 N123	pots	I.3. Pots with globular body, everted rim with rounded profile and externally thickened/ profiled lip	Dimensions – Rd – 14 cm, Wt – 0.5–0.6 cm, pH – 2.8 cm Hardness – hard Decoration/surface treatment – on the inner surface horizontal, parallel lines	Mineral inclusions – Type: polymodal grain size distribution; the most abundant grains are white, semi-transparent and greyish, very angular – sub-rounded, mostly equant – few elongate, 0.1–2 mm in size, with a platy habit and a glassy lustre (most probably calcite); sparse yellowish, mat grains, 0.5–1 mm in size. Size: 0.1–2 mm. Frequency: 15–20%. Porosity – low, sparse small pores (0.2–0.5 mm in size), most often isometric, very rare bigger pores (1–2 mm in size), anisometric	CROATIA Guran, Istria Ruffieux 2010: 259, Pl. 1: 9 – pots type I.D. CROATIA Principia in Rijeka Bekić 2009: Pl. 2: 2 ITALY Villaggio San Francesco a Comacchio Negrelli 2021: 207, Fig. 6: 1
10	2: 10	BG-S2 SJ76 N118	pots	I.3. Pots with globular body, everted rim with rounded profile and externally thickened/ profiled lip	Dimensions – Rd – 14 cm, Wt – 0.5–0.6 cm, pH – 3 cm Hardness – hard Decoration/surface treatment – outer surface smoothed	Mineral inclusions – Type: polymodal grain size distribution; the most abundant grains are white, semi-transparent and greyish, very angular – sub-rounded, equant – elongate, 0.1–2.5 mm in size, mat or with a glassy lustre (most probably calcite); reddish, reddish brown and dark red grains, which are 0.2–2 mm in size, equant or elongate, sub-rounded. Size: 0.1–2.5 mm. Frequency: 20–25%. Porosity – low, sparse small pores (0.2–0.5 mm in size), isometric and elongate, few bigger pores (0.5–1.5 mm) with irregular shape	CROATIA Guran, Istria Ruffieux 2010: 260, Pl. 2 – pots type I.F. CROATIA Lopar Novi Vinodolski Vrančić, Janeš 2020: 184, Pl. 2: 7 – pots type Ia CROATIA Principia in Rijeka Bekić 2009: Pl. 2: 5

No. / Broj	Plate no. / Tabla broj	Vessel / Posuda	Form / Oblik	Type / Tip	Morphology and decoration / Morfologija i ukras	Fabric description / Opis strukture	Analogies / Analogije
11	2: 11	BG-S2 SJ90 N130/4	pots	I.3. Pots with globular body, everted rim with rounded profile and externally thickened/profiled lip	Dimensions – Rd – 13.2 cm, Wt – 0.5 – 0.7 cm, pH – 3.1 cm Hardness – hard Decoration/surface treatment – incised thin horizontal lines on the shoulder	Mineral inclusions – Type: inclusions poorly sorted, polimodal grain size distribution; big grey, whitish and semi-transparent grains (0.5–2 mm in size), mostly equant, some elongate, sub-angular and sub-rounded, with glassy lustre; abundant fine grain fraction (0.1–0.5 mm), grains white, grey, yellowish, equant, angular and sub-angular. Size: 0.1–2 mm. Frequency: 10–20%. Porosity – very low	CROATIA Guran, Istria Ruffieux 2010: 259, Pl. 1.10 – pots type I. E. SLOVENIA Tonovcov Grad Modrijan, Milavec 2011: 541, Pl. 91: 15 – pots type 4 ITALY Invillino Bierbrauer 1987: Pl. 74: 4 – type IIIc1 ITALY Aquileia, Fondi Cossar Riccato 2020: 220, Pl. XXVI: 3, 5 – pots type 38
12	2: 12	BG-S2 SJ101 N129	pots	I.3. Pots with globular body, everted rim with rounded profile and externally thickened/profiled lip	Dimensions – Rd – 14 cm, Wt – 0.4 – 0.8 cm, pH – 4.3 cm Hardness – hard Decoration/surface treatment – incised horizontal, parallel grooves on shoulder	Mineral inclusions – Type: polimodal grain size distribution; the coarser white, greyish or semi-transparent grains are 0.5–4 mm in size; elongated and equant, angular and sub-angular, often with an isometric shape, a platy habit and a glassy lustre. Most probably calcite. Coarser reddish-brown grains, which are 0.5–1 mm in size, equant and sub-rounded. Rounded reddish grain, circa 2 mm diameter, with very fine, sub-rounded grains inside. The finer grain inclusions are white, greyish or semi-transparent; 0.2–0.5 mm in size, mostly equant, angular and sub-angular. Size: 0.2–4 mm. Frequency: 15–25%. Porosity – low	CROATIA Guran, Istria Ruffieux 2010: 259, Pl. 1 – pots type I. E. ITALY Villaggio San Francesco Comacchio Negrelli 2021: 207, Fig. 6: 6
13	2: 13	BG-S2 SJ53 N81	pots	I.3. Pots with globular body, everted rim with rounded profile and externally thickened/profiled lip	Dimensions – Rd – 15.8 cm, Md – 19.4 cm, Wt – 0.6 – 0.7 cm, pH – 10.9 cm Hardness – hard Decoration/surface treatment – wheel throwing marks on the inner surface under the rim; incised decoration – a wavy multiple lines (wavy band) of low amplitude, large deviation, nervous, carved with a multi-point tool on the shoulder	Mineral inclusions – Type: polimodal grain size distribution; white grains which are 0.2–2 mm in size, sharp-edged, with an isometric shape, a platy habit and a glassy lustre. The grains concentrate on the external and internal surfaces of the pot, which is visible also on the fracture. Most probably calcite. Reddish grains, which are 0.3–0.8 mm in size, equant and sub-rounded. Size: 0.2–2 mm. Frequency: 10–15%. Porosity – very low	CROATIA Guran/Istria Ruffieux 2010: 260, Pl. 2 – pots type I. F. CROATIA Brioni, Castrum Marušić 1986a: 88, Fig. 7: 2 CROATIA Lopar Novi Vinodolski Vrančić, Janež 2020: 184, Pl. 2: 7 – pots type Ie ITALY Ravenna, Classe Brogiolo, Gelichi 1986: 297, Pl. II: 1–4 Gelichi 1983: 129 – pots: 7.1; 7.2; 7.3; 7.4 ITALY Villaggio San Francesco Comacchio Negrelli 2021: 207, Fig. 6: 7 ITALY S. Maria in Pado Vetere Corti 2007: 574, Fig. 4: 4

No. / Broj	Plate no. / Tabla broj	Vessel / Posuda	Form / Oblik	Type / Tip	Morphology and decoration / Morfologija i ukras	Fabric description / Opis strukture	Analogies / Analogije
14	2: 14	PK S1 SJ48 N40/1	pots	I.3. Pots with globular body, everted rim with rounded profile and externally thickened/ profiled lip	Dimensions – Rd – 16.8 cm, Wt – 0.5–0.7 cm, pH – 2.7 cm Hardness – hard Decoration/surface treatment – on the rim on the inner surface – smoothed; horizontal, parallel and delicately defined traces of levigation by a stick are visible on the shoulder	Mineral inclusions – Type: polymodal grain size distribution; the most abundant grains are white, semi-transparent and greyish, very angular – sub-rounded, equant – elongate, 0.2–3 mm in size, with a platy habit and a glassy lustre (most probably calcite); some white grains are matt. Much less abundant brown, brownish-grey and dark grey grains, shiny, which are 0.3–0.8 mm in size, equant and sub-rounded; sparse yellowish-brown grains, 0.3–0.8 mm in size, matt. Size: 0.2–3 mm. Frequency: 10–15%. Porosity – very low, not very numerous pores, 0.5–1 mm in size, mainly isometric, few anisometric	CROATIA Guran, Istria Ruffieux 2010: 261, Pl. 3: 7 – pots type I, H. CROATIA Veštar Bekić 2014: 106, no. 13 CROATIA Principia in Rijeka Bekić 2009: Pl. 1: 5 CROATIA Lopar Novi Vinodolski Vrančić, Janeš 2020: 184, Pl. 2: 7 – pots type I SLOVENIA Tonovcov Grad Modrijan, Milavec 2011: 542, Pl. 92: 7 – pots type 4 ITALY Invillino Bierbrauer 1987: Pl. 76: 3–5 – type IIId4
15	3: 15	BG S2 SJ61 N112	pots	I.3. Pots with globular body, everted rim with rounded profile and externally thickened/ profiled lip	Dimensions – Rd – 13 cm, Wt – 0.6 cm, pH – 4 cm Hardness – hard Decoration/surface treatment – wheel throwing marks in the inner surface; incised decoration: horizontal, parallel lines/grooves on the shoulder	Mineral inclusions – Type: polymodal grain size distribution; the most abundant grains are white, semi-transparent and greyish, very angular – sub-rounded, equant – elongate, 0.1–3 mm in size, with a platy habit and a glassy lustre (most probably calcite); reddish grains, which are 0.2–0.5 mm in size, equant (less often elongated) and sub-rounded. Size: 0.1–3 mm. Frequency: 15–20%. Porosity – very low, sparse small pores (0.2–0.5 mm in size), mostly isometric	CROATIA Guran, Istria Ruffieux 2010: 259, Pl. 1: 11 – pots type: I, E. ITALY Invillino Bierbrauer 1987: Pl. 76: 3–5 – pots type IIId4? ITALY Oderzo Castagna, Spagno 1996: 85, Pl. 1: 13 – pots type 6/B
16	3: 16	BG S2 SJ72 N126/1	pots	I.4. Pots with globular body, everted rim with rounded profile, thinned at the tip, with groove for the lid	Dimensions – Rd – 19 cm, Wt – 0.4 – 0.6 cm, pH – 4.3 cm Hardness – hard Decoration/surface treatment – wheel throwing marks on the inner surface under the rim; incised decoration – on the shoulder a wavy multiple lines (wavy band) of low amplitude, large deviation, nervous, carved with a multi-point tool	Mineral inclusions – Type: polymodal grain size distribution; the most abundant grains are white, semi-transparent and greyish, very angular – sub-rounded, equant – elongate, 0.1–1.5 mm in size, with a platy habit and a glassy lustre (most probably calcite); reddish grains, which are 0.2–0.5 mm in size, equant (less often elongated) and sub-rounded; one big grain, 2 x 1.2 mm in size, brown, mat. Size: 0.1–1.5 mm. Frequency: 15–20%. Porosity – very low, sparse small pores (0.2–0.5 mm in size), mostly isometric, some elongated	CROATIA Betiga kod Barbarige Juroš-Mofardin 1986: 231, Pl. V: 2–3 CROATIA Guran, Istria Ruffieux 2010: 261, Pl. 3 – pots type I, H.
17	3: 17	PK S2 SJ71 N51/1	pots	I.4. Pots with globular body, everted rim with rounded profile, thinned at the tip, with groove for the lid	Dimensions – Rd – 19 cm, Wt – 0.6–0.8 cm, pH – 5.2 cm Hardness – hard Decoration/surface treatment – incised decoration – on the shoulder a decoration band consisting of several horizontal parallel lines, under which there is a strip of diagonal lines	Mineral inclusions – Type: polymodal grain size distribution; the most abundant grains are white, semi-transparent and greyish, very angular – sub-rounded, equant – elongate, 0.2–2.0 mm in size, with a platy habit and a glassy lustre (most probably calcite); sparse reddish-brown grains, which are 0.2–0.5 mm in size, equant and sub-rounded. Size: 0.2–2 mm. Frequency: 15–20%. Porosity – very low	Shape: AUSTRIA, Teurnia Rodríguez 1997: 167, Pl. 2: 11? Decoration: ITALIA Aquileia, Fondi Cossar Riccato 2020: 214, Pl. XX: 8 – pots type 34

No. / Broj	Plate no. / Tabla broj	Vessel / Posuda	Form / Oblik	Type / Tip	Morphology and decoration / Morfologija i ukras	Fabric description / Opis strukture	Analogies / Analogije
18	3: 18	PKS1 SJ121 PN-4/1	pots	1.4. Pots with globular body, everted rim with rounded profile, thinned at the tip, with groove for the lid	Dimensions – Rd – 16 cm, Wt – 0.6 – 0.9 cm, pH – 7.4 cm Hardness – hard Decoration/surface treatment – incised thin horizontal, parallel lines on the shoulder, carved with a multi-point tool	Mineral inclusions – Type: polimodal grains size distribution; the most abundant grains are white, semi-transparent and greyish, very angular – sub-rounded, equant – elongate, 0.2–2 mm in size, many with a platy habit and a glassy lustre (most probably calcite); some white grains are matt. Size: 0.2–2 mm. Frequency: 15–20%. Porosity – very low, not very numerous pores, 0.5–1 mm in size, mainly isometric	CROATIA Nesactium Marušić 1986b: 71, Pl. 8: 3 SLOVENIA Tonovcov grad Modrijan, Milavec 2011: 540, Pl 90: 6 – pots type 2 ITALY Aquileia, Fondi Cossar Riccato 2020: 221, Pl. XXVII: 3 – pots type 39; 222, Pl. XXVIII: 1–2 – pots type 40
19	3: 19	PKS1 SJ32 PN-24	pots	1.5. Pots with globular or biconic body, slightly everted, rounded rim	Dimensions – Rd – 20 cm, Wt – 0.8 – 1.1 cm, pH – 7.3 cm Hardness – hard Decoration/surface treatment – on the outer surface levigation (polishing, smoothing), especially on the neck; on the shoulder at least two wavy bands (multiple lines), carved with multi-point tool; rendering of the inner surface, vertical, parallel shallow grooves on the inner surface under the rim	Mineral inclusions – Type: polimodal grains size distribution; the most abundant grains are semi-transparent, white, greyish and dark grey, very angular – sub-rounded, equant – elongate, 0.2–2 mm in size, many with a platy habit and a glassy lustre (probably calcite); some grains are more rounded, greyish or brownish (sand?). Size: 0.2–2 mm. Frequency: circa 10–15%. Porosity – very low	SLOVENIA Koper Cunja 1996: Pl. 36: 380 CROATIA Virovitica Kiškorija South Jelinić Vučković 2015: 131, Fig. 139, 291, Pl. 23: 8 – type 1 pots, e.g. pot no. 209
20	4: 20	BG-S2 SJ78 N119/2	pots	1.5. Pots with globular or biconic body, slightly everted, rounded rim	Dimensions – Rd – 10.6 cm, Md – 13.4 cm, Wt – 0.7 cm, pH – 4.4 cm Hardness – hard Decoration/surface treatment – unsmoothed, and without decorations	Mineral inclusions – Type: polimodal grain size distribution; the most abundant grains are white, semi-transparent and greyish, very angular – sub-rounded, mostly equant – few elongate, 0.1–2 mm in size, with a platy habit and a glassy lustre (most probably calcite). Size: 0.1–2 mm. Frequency: 20–25%. Porosity – very low, sparse small pores (0.1–0.3 mm in size), most often isometric, few elongate.	ITALY Invillino Bierbrauer 1987: Pl. 106: 14 – pots type IIIa1–3
21	4: 21	BG-S2 SJ90 N130/3	pots	1.5. Pots with globular or biconic body, slightly everted, rounded rim	Dimensions – Rd – 0.8 – 1.1 cm, pH – 2.7 cm Hardness – hard Decoration/surface treatment – on the rim on the inner surface – smoothed	Mineral inclusions – Type: polimodal grain size distribution; white equant (few elongate), angular and sub-angular grains, mostly with an isometric shape and a glassy lustre, 0.2–1.2 mm in size; a few brown, dark brown grains – equant, sub-angular and sub-rounded, 0.2–0.5 mm in size; abundant minor inclusions. Size: 0.2–1.2 mm. Frequency: 10–15%. Porosity – very low	ITALY Invillino Bierbrauer 1987: Pl. 74 – pots type IIIc, ₁
22	4: 22	BG-S2 SJ92 N127/2	pots	1.5. Pots with globular or biconic body, slightly everted, rounded rim	Dimensions – Rd – 19 cm, Wt – 0.6 – 0.7 cm, pH – 2.9 cm Hardness – hard Decoration/surface treatment – on the inner surface – smoothed	Mineral inclusions – Type: mostly small grains (0.2–0.8 mm), elongated and equant, white, semi-transparent, transparent, greyish, dark grey, with a glassy lustre (quartz??); small mica grains with a platy habit and metallic lustre; bigger grains (1–1.5 mm) elongated and equant, sub-angular and sub-rounded, white, pinkish, transparent. Size: 0.2–1.5 mm. Frequency: 5–10%. Porosity – low	

No. / Broj	Plate no. / Tabla broj	Vessel / Posuda	Form / Oblik	Type / Tip	Morphology and decoration / Morfologija i ukras	Fabric description / Opis strukture	Analogies / Analogije
23	4: 23	BG-S2 SJ78 PN-55/1	pots	I.6. Pot with cylindrical body, everted and flattened rim	Dimensions – Rd – 17 cm, Md – 17 cm, Wt – 0.6 – 0.75 cm, pH – 8.7 cm Hardness – hard Decoration/surface treatment – incised decoration – on the walls under the rim thin horizontal, parallel lines/grooves, on the lines in the upper part of the vessel two wavy multiple lines (wavy band); wavy multiple lines on the upper surface of the rim, which is strongly everted outwards	Mineral inclusions – Type: polimodal grain size distribution; the most abundant grains are white, semi-transparent and grayish, very angular – sub-rounded, equant – elongate, 0.1–2 mm in size, with a platy habit and a glassy lustre (most probably calcite). Size: 0.1–2 mm. Frequency: 10–15%. Porosity – middle; small pores (0.2–0.8 mm in size), mostly isometric, some elongated, quite numerous on inner surface, a few on the outer surface	Decoration: SLOVENIA Ančnikovo gradišče Modrijan 2020: 322, Fig. 5 – pots type 1? Shape: SLOVENIA Ajdovski Gradec Knific 1994: Pl. 5: 7
24	4: 24	PK-S1 SJ121 PN-3	pots	I.7. Pot with almost vertical rim with internal ridge – (Fulford 35/ C.A.T.H.M.A 5)	Dimensions – Rd – 17.6 cm, Wt – 0.4–0.75 cm, pH – 8.5 cm Hardness – hard Decoration/surface treatment – wheel throwing marks on the inner surface under the rim: incised thin horizontal lines on the neck and shoulder	Mineral inclusions – Type – polimodal grain size distribution; the most abundant grains are yellowish, reddish brown, whitish, semi-transparent, 0.2–2 mm in size, equant and elongate, sub-angular – sub-rounded, shiny, the large grains (0.5–2 mm) are sparse, the most numerous are very fine grains (0.1–0.3 mm); sparse very pale brown, mat grains (0.5–1 mm in size), equant, sub-rounded; bright (silver, yellowish) mica grains. Size: 0.1–2 mm. Frequency: 10–15%. Porosity – low, sparse bigger pores, 1–1.5 mm in size, equant – elongate; small pores (0.2–0.5 mm in size), mostly isometric	Fulford 35/ C.A.T.H.M.A 5 (Fulford 1984: 187–189, Fig. 70; C.A.T.H.M.A. 1991: 35, Fig. 17)
25	5: 25	PK-S1 SJ96 N56/3	bases	II.1. Pots with flat base	Dimensions – Bd – 11.2 cm, Wt – 0.8 – 1 cm, pH – 4.4 cm Hardness – soft-hard Decoration/surface treatment – wheel throwing marks on the inner surface: on the outer surface incised thin horizontal lines	Mineral inclusions – Type: polimodal grains size; the most abundant grains are white, semi-transparent, greyish and dark grey, very angular – sub-rounded, equant – elongate, 0.1–2.5 mm in size, with a platy habit and a glassy lustre (most probably calcite). Size: 0.1–2.5 mm. Frequency: 15–20%. Porosity – very low, sparse pores, mostly isometric, few elongate	CROATIA Guran, Istria Ruffieux 2010: 264, Pl. 6: 10–11 – base type V. D.
26	5: 26	BG-S2 SJ99 N132/2	bases	II.1. Pots with flat base	Dimensions – Bd – 17 cm, Wt – 0.6–1 cm, pH – 5.1 cm Hardness – hard Decoration/surface treatment – on the outer surface incised thin horizontal, parallel lines	Mineral inclusions – Type: inclusions poorly sorted; polimodal grain size distribution; the coarser grey, whitish and semi-transparent, equant and elongate grains, are 0.5–3 mm in size, sub-angular and sub-rounded; many grains are isometric, with a glassy lustre; abundant fine greyish, whitish and semi-transparent grains, which are 0.1–0.5 mm in size, mostly equant, angular, sub-angular; few small reddish grains, which are 0.2–0.5 mm in size, mostly equant, sometimes elongate, sub-rounded. Size: 0.1–3 mm. Frequency: 20–30%. Porosity – low	ITALY Aquileia, Fondi Cossar: Riccato 2020: 212–213, Pl. XVIII: 4, Pl. XIX.2 – pots type 33

No. / Broj	Plate no. / Tabla broj	Vessel / Posuda	Form / Oblik	Type / Tip	Morphology and decoration / Morfologija i ukras	Fabric description / Opis struktura	Analogies / Analogije
27	5: 27	BGS2 SJ99 N132/3	bases	II.1. Pots with flat base	Dimensions – Bd – 19 cm, Wt – 0.8–1 cm, pH – 4.3 cm Hardness – hard Decoration/surface treatment – on the outer surface incised thin horizontal, parallel lines	Mineral inclusions – Type: inclusions poorly sorted, grain size distribution bimodal (or polymodal); the coarser grey, whitish and semi-transparent grains are 0.5–2 mm in size, equant and elongate, angular, sub-angular and sub-rounded, with a glassy lustre; some grains are isometric; abundant finer greyish, whitish and semi-transparent grains, which are 0.1–0.5 mm in size, mostly equant, angular, sub-angular; few small reddish-brown grains, which are 0.2–0.5 mm in size, mostly equant and sub-rounded. Size: 0.1–2 mm. Frequency: 10–20%. Porosity – low	ITALY Aquileia, Fondi Cossar Riccatò 2020: 212–213, Pl. XVIII: 4, Pl. XIX: 2 – pots type 33
28	5: 28	BGS1 SJ02 N7/1	caseroles/pans	III.1. Caseroles/pans with inverted rim	Dimensions – Rd – 20.2 cm, Md – 22 cm, Wd – 0.6 cm, pH – 2.9 cm Hardness – hard Decoration/surface treatment – on the outer and inner surface – smoothened	Mineral inclusions – Type: polymodal grain size distribution; the most abundant grains are white, semi-transparent and greyish, very angular – sub-rounded, equant – elongate, 0.1–2.5 mm in size, with a platy habit and a glassy lustre (most probably calcite); some bigger grains, 0.5–1.2 mm in size, are yellowish and mat; reddish grains, which are 0.2–1.2 mm in size, equant (less often elongated) and sub-rounded. Size: 0.1–2.5 mm. Frequency: 20–25%. Porosity – very low, sparse pores, mostly isometric	ITALY, Classe Ravenna Cavalazzi, Fabbri 2010: 627, Pl. 1: 1–4 – Casserole Cirelli, Cannavici 2014: 974, Fig. 10: 8–9 – Casserole Classe type ITALY Inwillino Bierbrauer 1987: Pl. 131: 4–5 – bowls typela ITALY Aquileia, Fondi Cossar Riccatò 2020: 228–229, Pl. XXXIV – XXXV – tegami, tipi 5
29	5: 29	PKS1 SJ25 PN25	caseroles/pans	III.1. Caseroles/pans with inverted rim	Dimensions – Rd – 24.2 cm, Wt – 0.5–0.7 cm, pH – 4.8 cm Hardness – hard Decoration/surface treatment – wheel throwing marks on the inner surface under the rim	Mineral inclusions – Type: polymodal grains size; the most abundant grains are semi-transparent, glossy, whitish, pale brown, brownish, greyish, grey, 0.2–2 mm in size, angular – sub-rounded, equant – elongate; some pale brown grains, 0.2–1 mm in size, are matt; a few reddish-brown grains, 0.3–1.5 mm in size, equant – elongate, sub-angular – sub-rounded; a few grains of light mica with a metallic sheen, 0.5–1 mm in size, elongate; a few clay interclasts. Size: 0.1–2 mm. Frequency: 15–25%. Porosity – low, few pores, 0.3–1.5 mm in size, most often isometric	ITALY, Classe Ravenna Cavalazzi, Fabbri 2010: 627, Pl. 1: 1–4 – Casserole Cirelli, Cannavici 2014: 974, Fig. 10: 8–9 – Casserole Classe type ITALY, S. Maria in Pado Vetere Corti, Loschi Ghittoni 2007: 520, Fig. 5: 8, 10
30	5: 30	PKS2 SJ1 N30/4	caseroles/pans	III.2. ACW – Hayes 23B – Culinaire type 1	Dimensions – Rd – 26 cm, Wt – 0.5–0.8 cm, pH – 3.1 cm Hardness – hard Decoration/surface treatment – smoothened	Mineral inclusions – Type: polymodal grains size; the most abundant grains are semi-transparent – transparent, light brown, greyish, grey, sub-rounded – rounded, equant – few elongate, 0.1–1 mm in size – sand?; few reddish brown grains, equant, sub-rounded, 0.2–0.5 mm in size. Size: 0.1–1 mm. Frequency: 5–10%. Porosity – very low, few isometric pores, 0.5–1.5 mm in size	Hayes 1972: 45–47; Bonifay 2004: 211
31	6: 31	PKS2 SJ44 N62/1	caseroles/pans	III.3. Caseroles with thickened rounded rim and biconic body	Dimensions – Rd – 19 cm, Md – 19.5 cm, Wt – 0.4–0.6 cm, pH – 6.4 cm Hardness – hard Decoration/surface treatment – inside horizontal, parallel and quite deep wheel throwing marks on the outer surface – smoothened	Mineral inclusions – Type: polymodal grain size distribution; the most abundant grains are semi-transparent, pale brown and light brownish grey, 0.2–0.8 mm in size, equant, sub-rounded and rounded, shiny (sand, probably quartz); few grains light red – pinkish, elongate, sub-rounded, 0.3–0.6 mm in size, shiny; very sparse larger grains (1–1.5 mm in size), equant, sub-rounded, very pale brown, mat. Size: 0.2–1.5 mm. Frequency: 10–15%. Porosity – very low	ITALY Rome, Ostia Bertoldi, Pacetti 2007: 435 – casse- ruole tipo 8 Ostia IV, Fig. 105

No. / Broj	Plate no. / Tabla broj	Vessel / Posuda	Form / Oblik	Type / Tip	Morphology and decoration / Morfologija i ukras	Fabric description / Opis struktura	Analogies / Analogije
32	6: 32	PK S2 SJ1 N30/3	casse- roles/ pans	III.4. ACW – Hayes form 197 – Culi- naire type 10	Dimensions – Hardness – hard Decoration/surface treatment –	A detailed analysis of the fabric of this sherd could not be carried out; it will be done during the next field campaign	Hayes 1972: 209; Bonifay 2004: 224, Fig. 120: 5, 6
33	6: 33	BG S2 SJ 90 N130/5	baking plates	IV.1. Baking plates with flat shape and rounded lip	Dimensions – Wt – 1.2–1.8 cm Hardness – hard Decoration/surface treatment – upper surface – smoothed	Mineral inclusions – Type: polymodal grain size distribution; the most abundant grains are white, semi-transparent and grayish, very angular – sub-rounded, mostly equant – elongate, 0.1–2.5 mm in size, with a platy habit and a glassy lustre (most probably calcite); sparse reddish grains, which are 0.3–1 mm in size, equant and sub-rounded. Size: 0.1–2.5 mm. Frequency: 10–15%. Porosity – very low, small pores (0.2–0.5 mm in size), most often isometric	SERBIA Horgoš/Horgos Vida 2016: 405, Fig. 19: 4–5
34	6: 34	BG S2 SJ90 N130/6	baking lids	V.1. Baking lid with a straight rim and rounded lip	Dimensions – Wt – 0.7 – 1 cm, pH – 3.1 cm Hardness – hard Decoration/surface treatment – incised decoration on the outer surface, horizontal, parallel and few diagonal lines/grooves	Mineral inclusions – Type: polymodal grain size distribution; the most abundant grains are white, semi-transparent and greyish, very angular – sub-rounded, equant – elongate, 0.1–2 mm in size, with a platy habit and a glassy lustre (probably calcite); sparse dark gray grains, which are 0.2–1 mm in size, equant and elongate, angular – sub-rounded. Size: 0.1–2 mm. Frequency: 10–15%. Porosity – very low, small pores (0.2–0.5 mm in size), most often isometric	CROATIA Guran/Istria Ruffieux 2010: 262–263, Pl. 4: 10–11, Pl. 5: 1–2 – type III. B
35	6: 35	BG S2 SJ90 N125/3	baking lids	V.2. Baking lid with convex wall and thickened lip	Dimensions – Wt – 0.7 cm, pH – 3.2 cm Hardness – hard Decoration/surface treatment – incised horizontal, parallel lines/ thin grooves on the inner surface	Mineral inclusions – Type: polymodal grain size distribution, grains poorly sorted; white, transparent and greyish, sub-angular – sub-rounded equant and elongate, 0.1–2.2 mm in size, with a platy habit and a glassy lustre (most probably calcite); quite numerous pale brown grains, 0.5–1.5 mm in size, mat; sparse reddish brown grains, which are 0.3–1.5 mm in size, equant – elongate and sub-rounded. Size: 0.1–2.2 mm. Frequency: 15–25%. Porosity – low, small pores (0.2–0.5 mm in size), most often isometric	CROATIA Guran/Istria Ruffieux 2010: 262, Pl. 4: 9 – type III. A ITALY Sant'Agata Bolognese Sbarra 2014: 166, Pl. 10: 5 – catini- coperchi Tipo 3
36	6: 36	BG S2 SJ90 N130/1	baking lids	V.3. Baking lid with convex wall and rounded lip	Dimensions – Rd – 28 cm, Wt – 0.75 – 0.9 cm, pH – 4.5 cm Hardness – hard Decoration/surface treatment – incised irregular, diagonal lines on the outer surface	Mineral inclusions – Type: very poorly sorted, polymodal grain size distribution; white, whitish and semi-transparent big grains, which are 1–3 mm in size, equant and elongate, angular with sharp edges and sub-angular, many grains have an isometric shape, a platy habit and a glassy lustre; medium-sized white, whitish and semi-transparent grains, which are 0.3–0.9 mm in size, equant and elongate, angular with sharp edges and sub-angular with a glassy lustre; very fine grain fraction (0.1–0.3 mm), grains white, yellowish, equant, angular and sub-angular; rare elongate, sub-rounded reddish brown grains. Size: 0.1–3 mm. Frequency: 20–30%. Porosity – medium – low	CROATIA Guran, Istria Ruffieux 2010: 262, Pl. 4: 9 – type: III. A ITALY Ravenna Classe Brogiolo, Gelichi 1986: 298, Pl. III: 5 Decoration: SLOVENIA Tonovcov Grad Modrijan, Milavec 2011: 525, Pl. 75: 8–10 Bowls, type 1

No. / Broj	Plate no. / Tabla broj	Vessel / Posuda	Form / Oblik	Type / Tip	Morphology and decoration / Morfolologija i ukras	Fabric description / Opis strukture	Analogies / Analogije
37	6: 37	BG S2 SJ74 N100/1	baking lids	V.4. Bowl-shaped baking lid with folded handles	Dimensions – Wt – 0.6–1 cm, pH – 2.4 cm Hardness – hard Decoration/surface treatment – well smoothed on the inner surface	Mineral inclusions – Type: polimodal grain size distribution; the most abundant grains are white, semi-transparent and greyish, very angular – sub-rounded, mostly equant – elongate, 0.1–2.5 mm in size, with a platy habit and a glassy lustre (most probably calcite); sparse reddish grains, which are 0.3–1 mm in size, equant and sub-rounded. Size: 0.1–2.5 mm. Frequency: 10–15%. Porosity – middle, small pores (0.2–0.5 mm in size), most often isometric, sparse bigger pores (1–3.5 mm in size), isometric and elongate	ITALY Milano Vida 2016: 400, Fig. 12: 4 ITALY Volta di Besta, Ledro B Vida 2016: 404, Fig.17: 7 AUSTRIA Teurnia/Sankt Peter in Holz Rodriguez 1997: Pl. 4: 33, 36
38	7: 38	BG S2 SJ74 N100/2	lids	V.1.1. Lids with regular, concave and externally thickened rim	Dimensions – Rd – 20 cm, Wt – 0.6 cm, pH – 1.7 cm Hardness – hard Decoration/surface treatment – outer surface is smoothed	Mineral inclusions – Type: polimodal grain size distribution; the most abundant grains are white, semi-transparent and greyish, very angular – sub-rounded, mostly equant – elongate, 0.1–2.5 mm in size, some grains with a platy habit and a glassy lustre (probably calcite); sparse reddish grains, which are 0.3–0.8 mm in size, equant and sub-rounded. Size: 0.1–2.5 mm. Frequency: 10–15%. Porosity – very low, small pores (0.2–0.5 mm in size), most often isometric	SLOVENIA Koper Cunja 1996: Pl. 36: 390 ITALY Aquileia, Fondi Cossar Riccato 2020: 240, Pl. XLVI: 6 – coperchi tipo 4
39	7: 39	BG S1 SJ5 N374	lids	V.1.1. Lids with regular, concave and externally thickened rim	Dimensions – Wt – 0.5 cm, pH – 1,1 cm Hardness – hard Decoration/surface treatment – smoothed on the inner surface	A detailed analysis of the fabric of this sherd could not be carried out; it will be done during the next field campaign	SLOVENIA Koper Cunja 1996: Pl. 36: 390
40	7: 40	PK S1 SJ9 PN2	lids	V.1.2. ACW – Hayes 196 – Culinnaire C/A type 11	Dimensions – Hardness – hard Decoration/surface treatment –	A detailed analysis of the fabric of this sherd could not be carried out; it will be done during the next field campaign.	Hayes 1972: 207; Bonifay 2004: 226, Fig. 121
41	7: 41	BG S2 SJ78 N119/1	undetermined		Dimensions – Wt – 0.8 cm, pH – 4,1 cm Hardness – hard Decoration/surface treatment – unsmoothed	Mineral inclusions – Type: polimodal grain size distribution; the most abundant grains are white, semi-transparent and greyish, very angular – sub-rounded, mostly equant – few elongate, 0.1–4 mm in size, with a platy habit and a glassy lustre (most probably calcite), abundant fine fraction (0.1–0.5 mm in size), quite numerous large grains 1–4 mm in size; sparse reddish grains, which are 0.2–1 mm in size, equant or elongate, sub-rounded. Size: 0.1–4 mm. Frequency: 20–25%. Porosity – very low, sparse small pores (0.2–0.5 mm in size), most often isometric	

Tab. 1 Catalogue of vessels classified by form and type, with detailed descriptions of fabrics and analogies. Rd – rim diameter; Md – maximum diameter; Bd – base diameter; Wt – wall thickness; pH – partial height; Hardness: soft – can be scratched by a fingernail; hard – can be scratched by a knife; very hard – can be scratched by a window glass plate (made by: B. Nowacki)
Tab. 1 Katalog posuda klasificiranih prema oblici i tipu, s detaljnim opisom keramičkih struktura i analogijama. BG – Beži Grad; PK – Podkućine. Dimenzije: Rd – promjer oboda; Md – najveći promjer; Bd – promjer dna; Wt – debljina stijenke; pH – djelomična visina. Tvrdoa (hardness): soft – mekana, može se zarežati noktom; hard – tvrda, može se zarežati nožem; very hard – vrlo tvrda, može se zarežati prozorskim staklom (izradio: B. Nowacki)

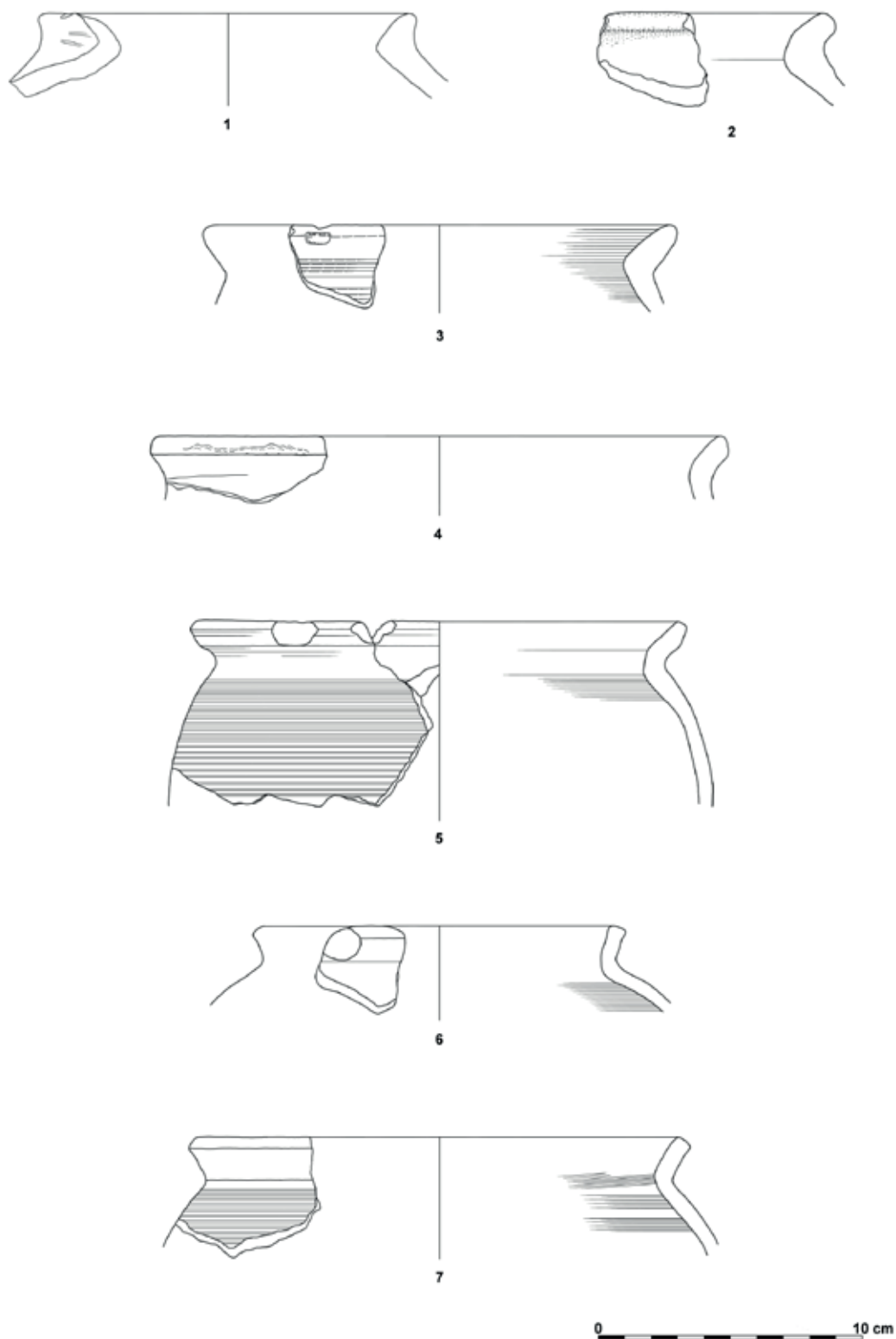

Pl. 1 Pots type I.1.: 1-3; pots type I.2.: 4-7 (drawings: B. Nowacki)
 T. 1 Lonci tip I.1.: 1-3; lonci tip I.2.: 4-7 (crteži: B. Nowacki)

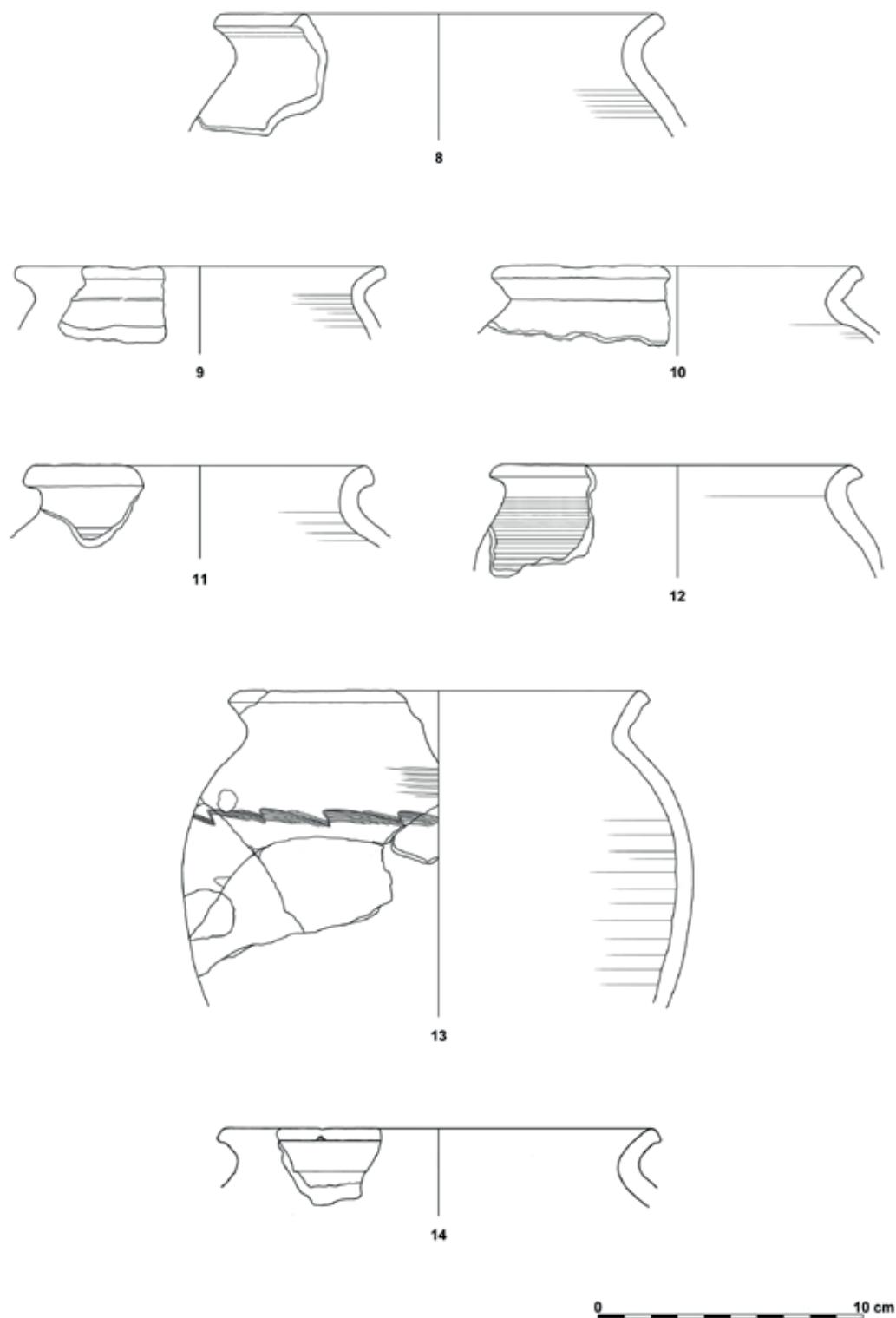

Pl. 2 Pot type I.2.: 8; pots type I.3.: 9-14 (drawings: B. Nowacki)
T. 2 Lonac tip I.2.: 8; lonci tip I.3.: 9-14 (crteži: B. Nowacki)

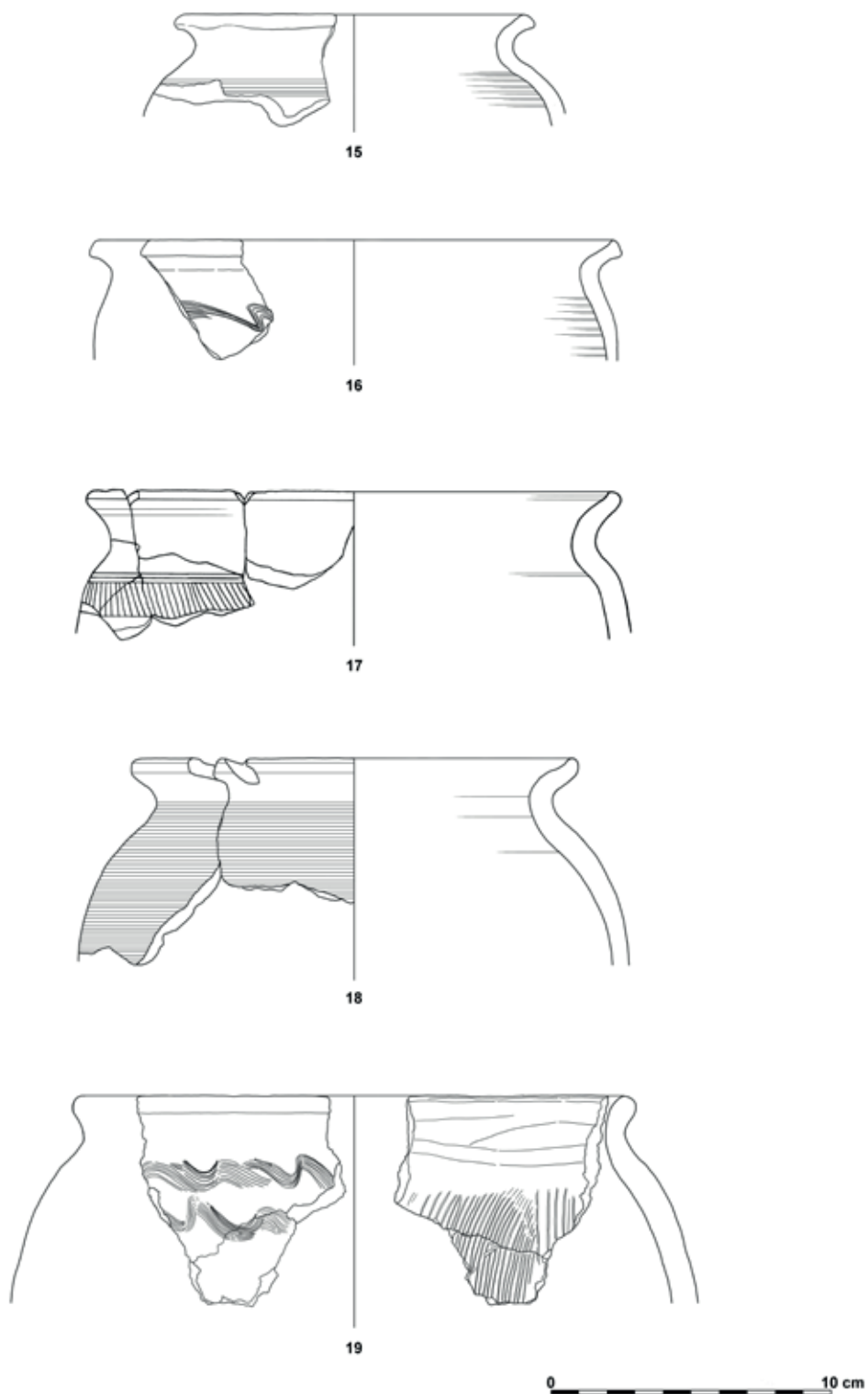

Pl. 3 Pots type I.3.: 15; pots type I.4.: 16-18; pots type I.5.: 19 (drawings: B. Nowacki)
 T. 3 Lonac tip I.3.: 15; lonci tip I.4.: 16-18 (crteži: B. Nowacki)

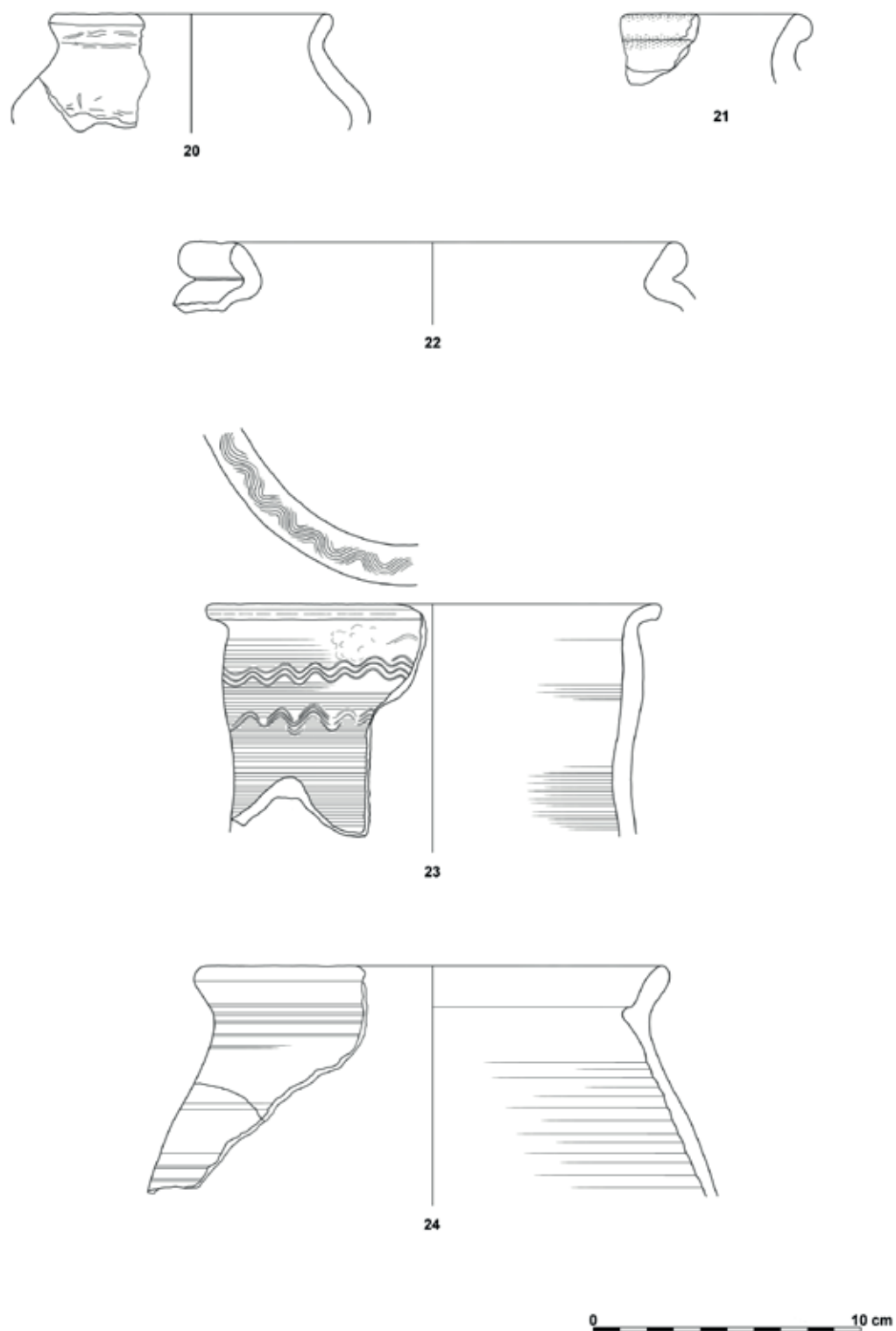

Pl. 4 Pots type I.5.: 20–22; pot type I.6.: 23; pot type I.7.: 24 (drawings: B. Nowacki)
T. 4 Lonci tip I.5.: 20–22; lonac tip I.6.: 23; lonac tip I.7.: 24 (crteži: B. Nowacki)

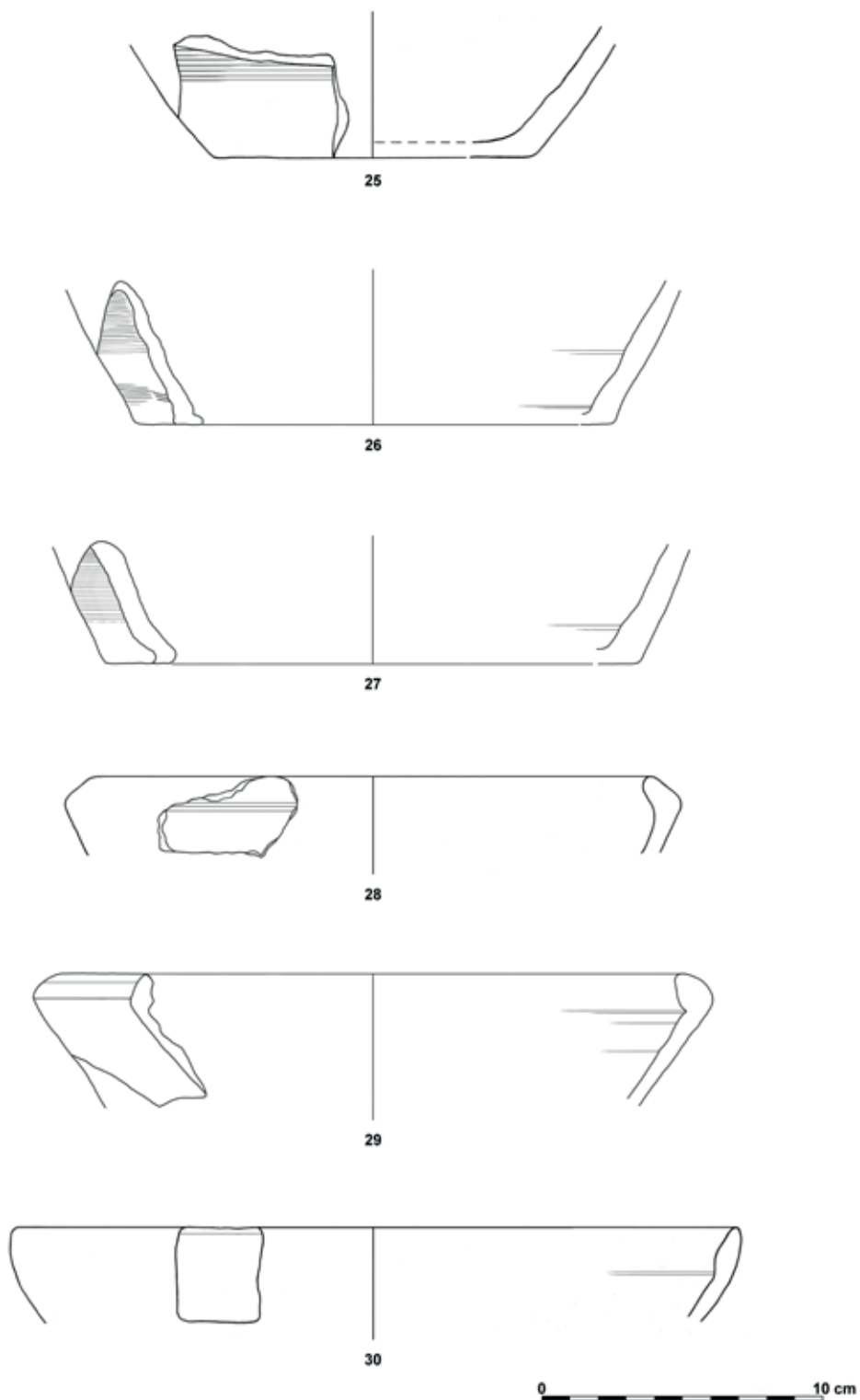

Pl. 5 Bases type II.1.: 25-27; casseroles/pans type III.1.: 28-29; casserole/pan type III.2.: 30 (drawings: B. Nowacki)
 T. 5 Dna tip II.1.: 25-27; kaserole/tave tip III.1.: 28-29; kaserola/tava tip III.2.: 30 (crteži: B. Nowacki)

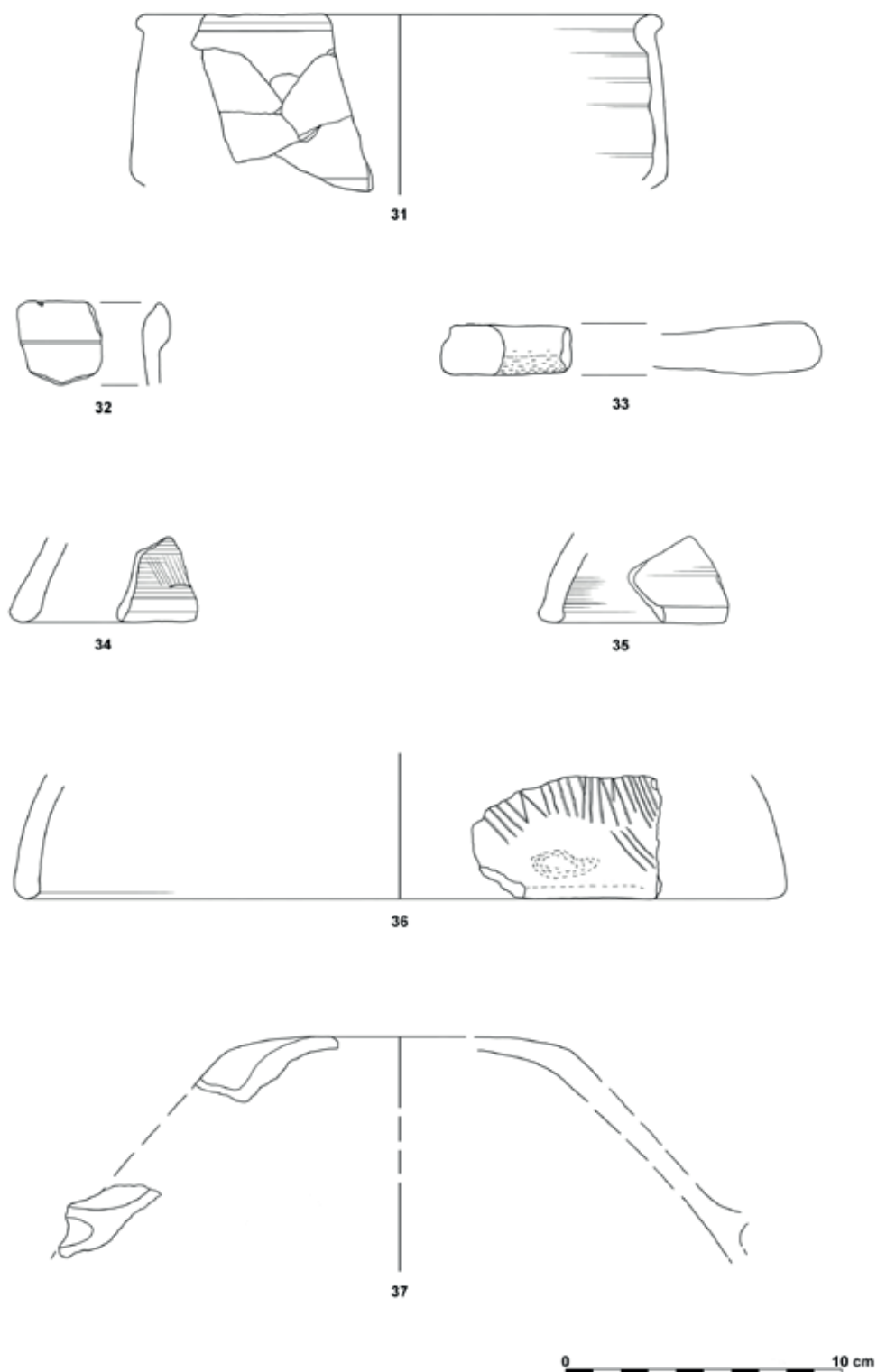

Pl. 6 Casserole type III.3.: 31; casserole/pan type III.4.: 32; baking plate type IV.1.: 33; baking lid type V.1.: 34; baking lid type V.2.: 35; baking lid type V.3.: 36; baking lid type V.4.: 37 (drawings: B. Nowacki)

T. 6 Kaserola tip III.3.: 31; kaserola/tava tip III.4.: 32; pekač tip IV.1.: 33; peka tip V.1.: 34; peka tip V.2.: 35; peka tip V.3.: 36; peka tip V.4.: 37 (crteži: B. Nowacki)

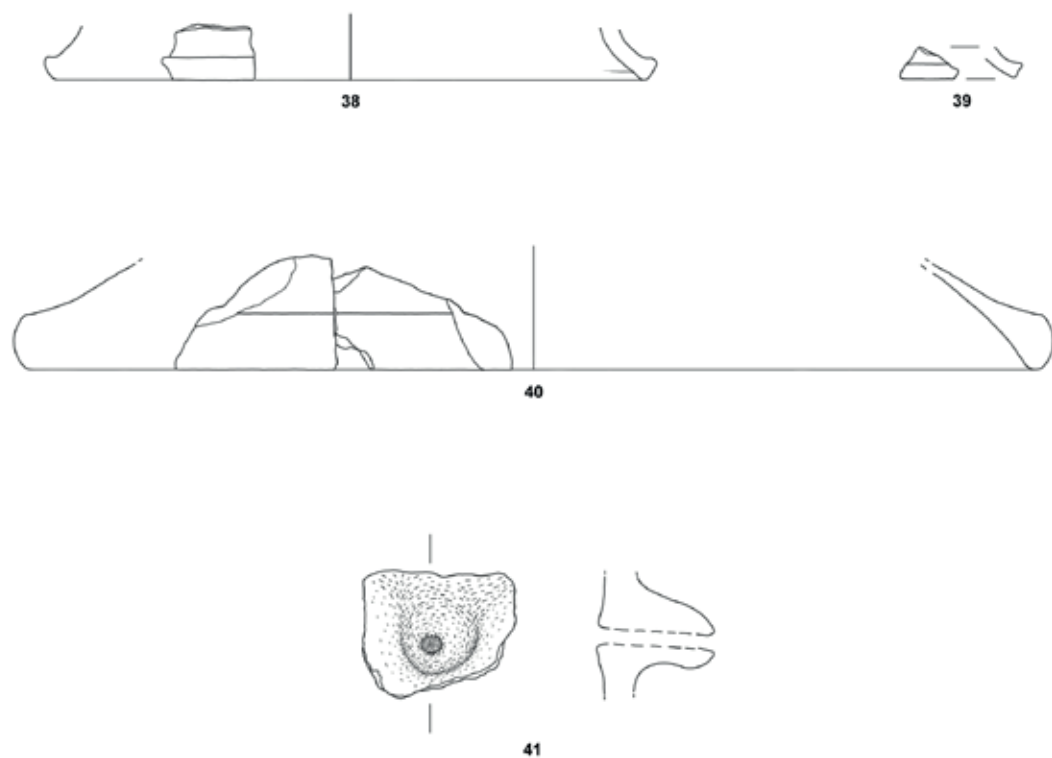

0 10 cm

Pl. 7 Lids type VI.1.: 38–39; lid type VI.2.: 40; undetermined vessel: 41 (drawings: B. Nowacki)
 T. 7 Poklopci tip VI.1.: 38–39; poklopac tip VI.2.: 40; nedeterminirana posuda: 41 (crteži: B. Nowacki)