



# Analysis of Container Terminal Handling System Based on Petri Net and ExtendSim

Danfeng DU<sup>1</sup>, Tiantian LIU<sup>2</sup>, Chun GUO<sup>3</sup>

Original Scientific Paper  
Submitted: 11 June 2022  
Accepted: 12 Jan. 2023

- <sup>1</sup> Corresponding author, ddf72@nefu.edu.cn, School of Traffic and Transportation, Northeast Forestry University  
<sup>2</sup> 17737405280@163.com, School of Traffic and Transportation, Northeast Forestry University  
<sup>3</sup> 1450720698@qq.com, Research and Development Center of Automotive Product, Midea Cloud Technology Co.



This work is licensed under a Creative Commons Attribution 4.0 International License.

Publisher:  
Faculty of Transport and Traffic Sciences,  
University of Zagreb

## ABSTRACT

The container terminal handling system plays an important role in marine transportation, and improving its efficiency has become a big challenge. Therefore, this paper proposes an analytical method that combines a Petri net with simulation tools. Firstly, the container terminal handling system is abstracted into a Petri net system according to the internal logic of the handling process. Next, eigenvalues of the correlation matrix are calculated to analyse the effectiveness of the Petri net system. Then, the Petri net system is simulated using the ExtendSim software. The result suggests that, after optimising, the handling capacity of the berth is clearly improved. Using the Petri net and simulation tools together to analyse the container terminal system is the innovation and the most important aspect of this paper. Because the combination of a Petri net and simulation can not only ensure the reliability of the model but also optimise the container terminal handling system more intuitively.

## KEYWORDS

container terminal; handling system; Petri net; correlation matrix; eigenvalue calculation; simulation.

## 1. INTRODUCTION

With the development of economic globalisation [1], the volume of international trade is gradually increasing. Around 80% of global trade is transported by sea and handled by terminals worldwide [2]. Container transportation has become the major mode of maritime transportation, with its advantages of high freight quality, high transportation efficiency and low transportation cost [3]. The container terminal is a key node of the global container transportation network. It is the place where container ships dock, load and unload. It plays an irreplaceable role in container transportation. In recent years, the throughput of global container terminals has increased rapidly [4–7]. Even affected by COVID-19, the global container throughput in 2021 was still growing at a rate of 6.5% [8]. The rapid growth of the throughput makes the workload of container terminals heavier [9]. Therefore, it is of great significance to improve the efficiency of the container terminal handling system.

The focus of this paper is to develop an analytical method combining a Petri net with simulation to improve the efficiency of the container terminal handling system. The following section reviews previous studies on how to improve the handling efficiency of container terminals. Then, Section 3 discusses how to analyse the container terminal operating system using a Petri net and ExtendSim. Section 4 shows the

simulation results. Next, Section 5 focuses on the optimisation of the simulation system. Finally, Section 6 summarises the research findings, points out the shortcomings of this paper, and discusses future research.

## 2. LITERATURE REVIEW

Improving the handling efficiency of container terminals has become a concern of scholars all over the world. The most widely used method is to establish a mathematical model. Said et al. [10] considered handling problems at container terminals as NP-hard combinatorial optimisation problems. They built a model to minimise the handling time and then proposed an optimisation methodology using the genetic algorithm. Msakni et al. [11] proposed a mixed-integer programming model and a method based on a binary search to determine the optimal loading and unloading schedule for berthed ships. Dkhil et al. [12] developed an integrated model to minimise total operating costs considering the storage location and vehicle scheduling problems during the unloading process and used a tabu search as the solution method. Dik and Kozan [13] proposed a flexible neighbourhood search strategy based on the tabu search (TS) algorithm framework to study the quay crane scheduling problem and eliminated the influence of fixed jobs on the generated scheduling by dynamically changing TS flexible jobs. Kizilay et al. [14] proposed mixed integer programming (MIP) and constraint programming (CP) models to study the integrated problems of quay crane allocation, quay crane scheduling, yard location-allocation and vehicle scheduling operations in container terminals, so as to maximise terminal throughput. Jonker et al. [15] established a coordinated scheduling model for waterside operations of container terminals in the form of a hybrid flow shop (HFS) and solved the model by a tailored simulated annealing (SA) algorithm to obtain the optimal scheduling of quay cranes. Zhuang et al. [16] regarded the integrated scheduling problem of container terminal handling equipment as the blocking hybrid flow shop scheduling problem with bidirectional flows and limited buffers. They developed a compact mixed-integer linear programming model and used an adaptive large neighbourhood search method to solve it.

Container terminals are too complex to be modelled mathematically [17]. Therefore, many scholars optimise the container terminal handling system by simulation. Sun et al. [18] used an improved multi-agent system to represent the various operating processes and different equipment of the container terminal based on the Microport simulation platform, which greatly reduced the modelling work and contributed to the planning and design of integrated solutions for the container terminal. Clausen et al. [19] used ContSim to model the container terminal and identify the factors that restrict the efficiency of container terminal operations, aiming to obtain the best operational strategy to improve efficiency. He et al. [20] proposed a simulation optimisation method, which integrates the genetic algorithm (GA) searching and simulation to improve the loading and unloading efficiency of container terminals by sharing inner cards among multiple container terminals. Schroër et al. [21] studied the efficiency of outer truck transportation between container terminals in Rotterdam, and they proposed an object-oriented and discrete simulation model to analyse how delays due to traffic would affect system performance. Abourraja et al. [22] proposed a multi-agent simulation model including an improved crane scheduling strategy inspired by the ant colony algorithm, which reduces the working time of quay cranes. Castilla-Rodríguez [23] proposed an intelligent system that integrates artificial intelligence techniques and simulation tools to generate a high-quality crane schedule so that cranes can be reasonably scheduled and the handling efficiency of container terminals can be improved. Muravev et al. [24] used AnyLogic to optimise the main parameters of the multi-modal terminal in two stages, and took Zhoushan port, one of the busiest ports in China, as an example to prove the sufficiency and effectiveness of the simulation model established. Rožić et al. [25] combine mathematical models and simulations to study the location assignment of the container terminal. They developed a network-based mathematical model and then validated the model within the FlexSim CT simulation environment.

Because the container terminal handling system is discrete and dynamic, some scholars use a Petri net to study it. Kemper and Fischer [26] applied a stochastic Petri net to model a cargo terminal to determine the waiting space of the set card, thus improving the operational efficiency of the terminal. Fu and Zhong [27] used the CPN Tool, a coloured Petri net modelling tool, to conduct container terminal simulation modelling, so as to obtain data in the simulation process and analyse the maximum queue length and average waiting time. Cavone et al. [28] applied a timed Petri net and cross-efficiency data envelope analysis (DOA) multi-criteria optimisation techniques to terminal resource management, thus helping decision-makers solve problems, such as how to determine berth capacity and ship schedule to cope with cargo flow increase.

At present, container terminal handling system research mostly focuses on the establishment of mathematical models and the use of simulation methods. Only a small part of the literature has applied Petri nets to this field. Therefore, using a Petri net to analyse the container terminal handling problem needs more in-depth research. In this paper, the simulation technology and Petri net idea are combined to analyse the container terminal handling system. First, the handling process of the container terminal system is described logically by Petri net. Next, a mathematical method is used to calculate the reliability of the Petri net system, then, on this basis, the container terminal handling system is simulated. In this way, the feasibility of the simulation is guaranteed, and the container terminal handling system can be optimised more intuitively.

### 3. METHODS

The container terminal handling system is composed of three modules – the ship entry module, the ship operating module and the yard operating module [29, 30]. The ship entry module is mainly concerned with the docking and berthing of ships, while the ship operating module is made up of two parts – ship loading and ship unloading. The yard operating module mainly includes inner truck transportation and outer truck transportation. The structure of the container terminal handling system is illustrated in *Figure 1*.

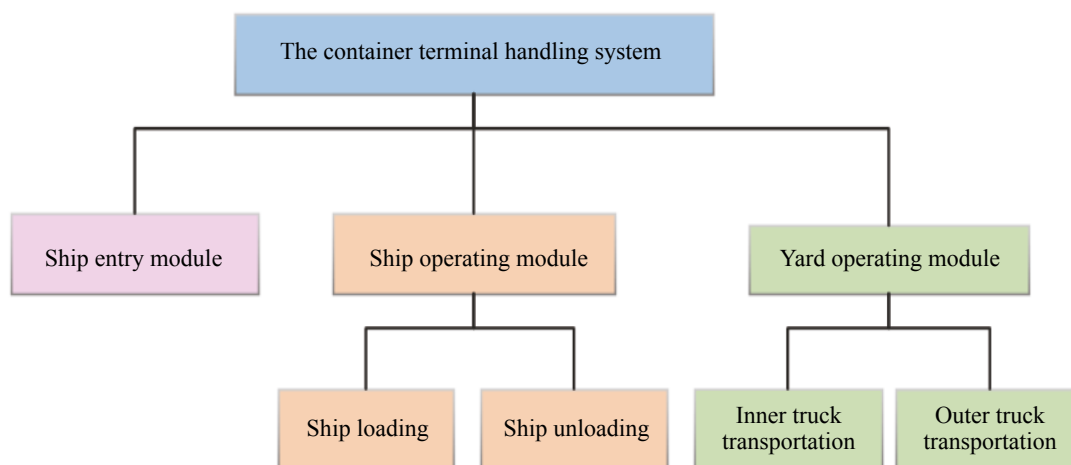

*Figure 1 – The structure of the container terminal handling system*

The examination of the literature shows that Petri net and simulation are applied separately to improve the efficiency of the container terminal handling system. However, Petri net and simulation are combined in this study. The terminal handling system is described by a Petri net, and eigenvalues of the correlation matrix are used to calculate the reliability of the Petri net process. The ExtendSim software is used to simulate and optimise the system terminal handling more intuitively based on the Petri net system. A brief description of the methods used is given in *Figure 2*.

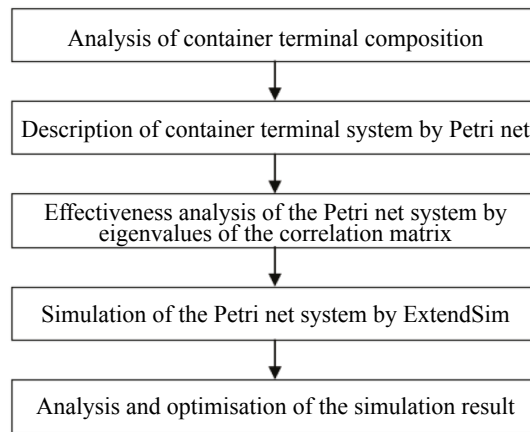

Figure 2 – Flowchart of the study

### 3.1 Petri net

A Petri net can not only describe the structural characteristics of the system but also simulate the state changes in the actual system operation process. At the same time, a Petri net can also reflect the sequence, synchronisation, asynchrony, concurrency and conflict relations of each component in the system. A Petri net has no global control flow and no central control. It only describes dependencies of things, including the causality and the control mechanism objectively existing in the physical system [31–35].

This paper uses the basic network system, which can be described as follows:  $\Sigma=(P,T;F,M_0)$ , where  $P$  is the nonempty finite set of places,  $T$  is the nonempty finite set of transitions,  $F$  is the directed arc set, and  $M_0$  is the initial mode.

Place is used to describe the local state, resources, conditions or information of the system. It is generally represented by circles. Transition is used to describe an event that changes the state of a system. It is usually represented by rectangles.  $F$  is the directed arc set, which is the set of input and output arcs of transition.

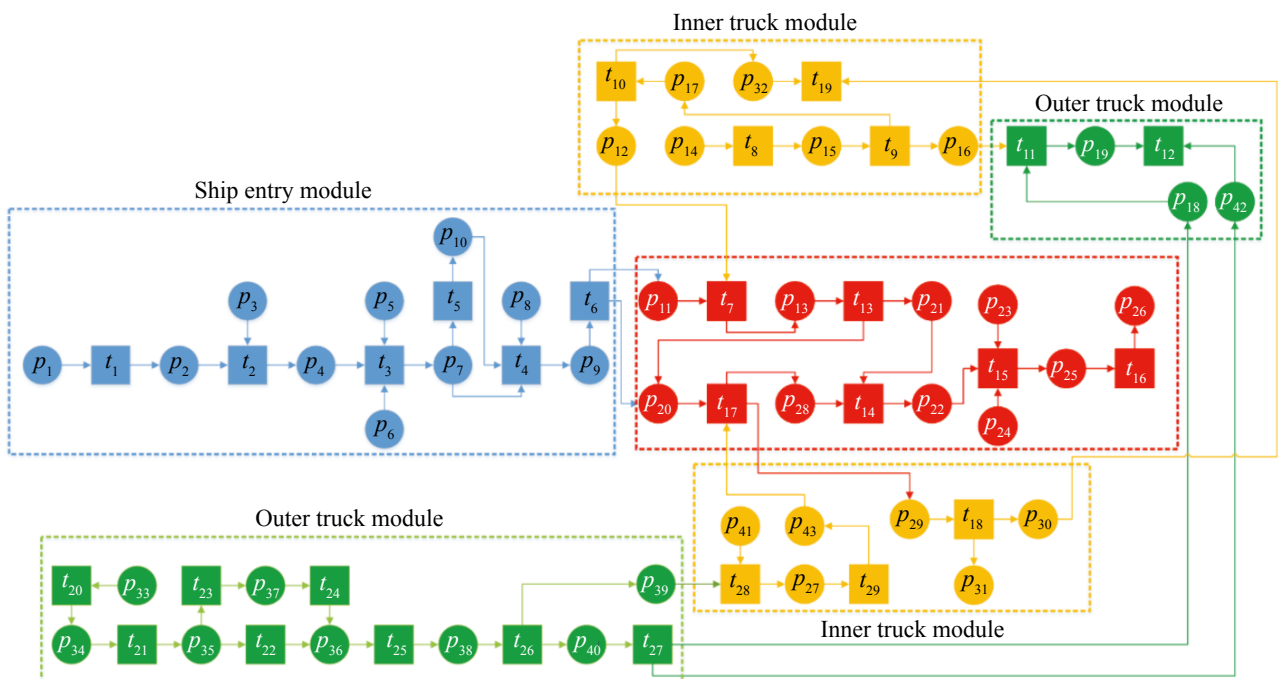

Figure 3 – The Petri net system of container terminal handling operations

The main research object of this study is the container terminal handling system. Its process is discrete, dynamic, complex and uncertain, which meets the requirements of a Petri net. Therefore, a Petri net is used in this paper to describe the handling process of the container terminal.

According to the composition of the container terminal handling system [36], a Petri net is used to model the container terminal handling system in blocks. The whole system is divided into four blocks, which are the ship entry module, the ship operating module, the inter truck operating module and the outer truck operating module. The specific Petri net system is shown in *Figure 3*, and the meaning of places and transitions involved in it is shown in *Table 1*.

According to the Petri net system shown in *Figure 3*, the process of container terminal handling operations can be seen intuitively. First, vessels arrive at the port. Then they load or unload depending on vessel type, which involves the horizontal transportation of containers between the front edge of the wharf and the rear yard by the inner trucks and the collecting and dispatching operation between the yard and the dock gate by the outer truck.

### 3.2 Eigenvalues of incidence matrices

A Petri net with one output arc at most for each place is called a choice-free net (CF net for short), and there is no conflict structure in a CF net. A Petri net with one output arc at most for each transition is called a link-free net (LF net for short), and there is no concurrency structure in an LF net [37].

The matrices  $U$  and  $V$  are defined as follows:

$$U = [u_{ij}]_{m \times n}, \quad u_{ij} = \begin{cases} 1, & p_i \in {}^*t_j \\ 0, & \text{otherwise} \end{cases} \quad (1)$$

$$V = [v_{ij}]_{m \times n}, \quad v_{ij} = \begin{cases} 1, & p_i \in t_j^* \\ 0, & \text{otherwise} \end{cases} \quad (2)$$

Assuming that  $H$  is the incidence matrix in the Petri net:

$$H = [h_{ij}]_{m \times n}, \quad h_{ij} = \begin{cases} -1, & p_i \in {}^*t_j \\ 1, & p_i \in t_j^* \\ 0, & \text{otherwise} \end{cases} \quad (3)$$

In a CF net and an LF net, let

$$W = H^T U \quad (4)$$

$$Z = HV^T \quad (5)$$

For non-CF net and non-LF nets, matrices  $W$  and  $Z$  need to be transformed into  $\tilde{W}$  and  $\tilde{Z}$ , and the transformation process is as follows:

$$\tilde{W} = [\tilde{w}_{ij}]_{m \times n}, \quad \tilde{w}_{ij} = \begin{cases} \max(0, w_{ij}), & i \neq j \\ w_{ij}, & i = j \end{cases} \quad (6)$$

$$\tilde{Z} = [\tilde{z}_{ij}]_{m \times n}, \quad \tilde{z}_{ij} = \begin{cases} \min(0, z_{ij}), & i \neq j \\ z_{ij}, & i = j \end{cases} \quad (7)$$

There are 5 theorems [38] based on the eigenvalues of matrix  $M$  to judge the structure boundedness, structure repeatability and coordination of a Petri net.

Theorem 1: If the Petri net is a CF net and all real eigenvalues of  $W$  are non-positive, then the Petri net is structurally bounded.

Theorem 2: If the Petri net is an LF net and all real eigenvalues of  $Z$  are non-negative, then the Petri net is structurally repeatable.

Table 1 – The meaning of places and transitions that are involved in the Petri net system of container terminal handling operations

Places			
$p_1$	The ship arriving at the port	$p_{23}$	No incoming ships in the channel
$p_2$	The ship waiting at an anchorage outside the harbour	$p_{24}$	Meet the safe distance from the departing ship
$p_3$	The anchorage in the harbour is free	$p_{25}$	The outbound ship in the channel
$p_4$	The ship entering an anchorage in a harbour	$p_{26}$	The ship leaving the port
$p_5$	No outbound ships in the channel	$p_{27}$	The inner truck with export containers
$p_6$	Meet the safe distance from the incoming ship	$p_{28}$	The ship finished the loading operation
$p_7$	The ship entering the channel	$p_{29}$	The inner truck completed the container loading operation
$p_8$	The berth is free	$p_{30}$	The inner truck not participating in the loading operation
$p_9$	The ship that has finished berthing	$p_{31}$	The inner truck participating in the loading operation
$p_{10}$	The ship waiting for free berth	$p_{32}$	The inner truck not participating in the unloading operation
$p_{11}$	The ship that needs to be unloaded	$p_{33}$	Ship arrival plan
$p_{12}$	The inner truck for unloading the ship	$p_{34}$	The terminal received the plan
$p_{13}$	The ship finished unloading operation	$p_{35}$	The outer truck with the export containers arriving at the terminal gate
$p_{14}$	The inner truck with import containers	$p_{36}$	The outer truck that has been checked out
$p_{15}$	The inner truck with the containers arriving at the yard	$p_{37}$	The Control Centre gets the message
$p_{16}$	Import containers that are unloaded	$p_{38}$	The outer truck arriving at the designated location in the yard
$p_{17}$	The inner truck that completes the container unloading operation	$p_{39}$	The export container placed in designated locations
$p_{18}$	The outer truck for the container loading operation	$p_{40}$	The outer truck that finished the container unloading task
$p_{19}$	The outer truck with imported containers	$p_{41}$	The ship loading plane
$p_{20}$	The ship that needs to be loaded	$p_{42}$	The outer truck not participating in vanning
$p_{21}$	The ship that does not need to be loaded	$p_{43}$	Containers stacked on the shore
$p_{22}$	The ship waiting to depart		
Transitions			
$t_1$	The ship in port waits to berth in the anchorage outside the harbour	$t_{16}$	The ship leaves the port
$t_2$	The ship enters the anchorage in the harbour	$t_{17}$	The quayside container crane is loading the ship
$t_3$	The ship enters the channel	$t_{18}$	Determine whether the inner truck will continue to participate in the loading operation
$t_4$	The ship berths	$t_{19}$	The inner truck returns to the parking lot
$t_5$	The ship waits for free berth	$t_{20}$	Make the container concentration plane and send it to the terminal
$t_6$	The Centre determines the type of ship	$t_{21}$	Arrange for the outer truck to transport export containers to the yard at a specific time
$t_7$	The quayside container crane unloads the ship	$t_{22}$	The outer truck enters the gate and for inspection
$t_8$	The inner truck delivers the container to the yard	$t_{23}$	Send the arrival information about export containers and outer trucks
$t_9$	he container yard crane carries out the unloading operation	$t_{24}$	The Centre makes the plan about transporting containers and tells drivers
$t_{10}$	Determine whether the inner truck will continue to participate in the unloading operation	$t_{25}$	The outer truck arrives at the yard
$t_{11}$	The container yard crane is loading containers	$t_{26}$	The container yard crane is unloading containers
$t_{12}$	The outer truck leaves the port	$t_{27}$	Determine whether the outer truck will continue to participate in the loading operation
$t_{13}$	Determine whether the ship needs to be loaded	$t_{28}$	The container yard crane places containers into the inner truck
$t_{14}$	The ship is waiting to leave the port	$t_{29}$	The quayside container crane unloads containers on the shore
$t_{15}$	The leaving ship enters the channel		



Theorem 3: If the Petri net is an LF net and 0 is a simple eigenvalue of  $Z$ , and all other real eigenvalues are positive, then the Petri net is compatible.

Theorem 4: If the Petri net is a non-CF net and all the real eigenvalues of  $\tilde{W}$  are non-positive, then the Petri net is structurally bounded.

Theorem 5: If the Petri net is a non-LF net and all the real eigenvalues of  $\tilde{Z}$  are non-negative, then the Petri net is structurally repeatable.

The whole Petri net system for the container terminal handling operation involves a large number of places and transitions, and its structure is relatively complex. It is difficult to directly analyse the eigenvalues of incidence matrices. Therefore, the whole system is analysed into modules.

*Ship entry module*

By analysing the Petri net of ship entry module in *Figure 4*, it can be seen that there is one output arc at most for each place and one output arc at most for each transition. Therefore, the ship entry module belongs to both a CF net and an LF net.

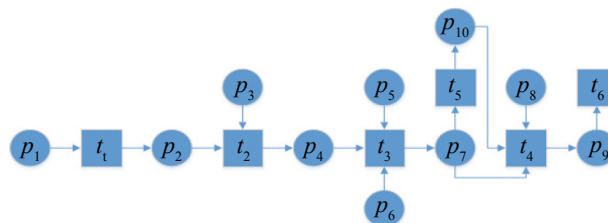

Figure 4 – The Petri net of ship entry module

First, the incidence matrix  $A$  of the ship entry module is calculated according to *Formula 3*. Then  $U(A)$  and  $V(A)$  are calculated according to *Formulas 1 and 2*, respectively. Finally,  $W(A)$  and  $Z(A)$  are calculated according to *Formulas 4 and 5*:

$$W(A) = A^T U(A) = \begin{bmatrix} -1 & 1 & 0 & 0 & 0 & 0 \\ 0 & -2 & 1 & 0 & 0 & 0 \\ 0 & 0 & -3 & 1 & 1 & 0 \\ 0 & 0 & 0 & -3 & -1 & 1 \\ 0 & 0 & 0 & 0 & -1 & 0 \\ 0 & 0 & 0 & 0 & 0 & -1 \end{bmatrix} \quad Z(A) = AV^T(A) = \begin{bmatrix} 0 & -1 & 0 & 0 & 0 & 0 & 0 & 0 & 0 & 0 \\ 0 & 1 & 0 & -1 & 0 & 0 & 0 & 0 & 0 & 0 \\ 0 & 0 & 0 & -1 & 0 & 0 & 0 & 0 & 0 & 0 \\ 0 & 0 & 0 & 1 & 0 & 0 & -1 & 0 & 0 & 0 \\ 0 & 0 & 0 & 0 & 0 & 0 & -1 & 0 & 0 & 0 \\ 0 & 0 & 0 & 0 & 0 & 0 & -1 & 0 & 0 & 0 \\ 0 & 0 & 0 & 0 & 0 & 0 & 1 & 0 & -1 & -1 \\ 0 & 0 & 0 & 0 & 0 & 0 & 0 & 0 & -1 & 0 \\ 0 & 0 & 0 & 0 & 0 & 0 & 0 & 0 & 1 & 0 \\ 0 & 0 & 0 & 0 & 0 & 0 & 0 & 0 & -1 & 1 \end{bmatrix}$$

After calculation,  $W(A)$  has 6 eigenvalues, which are respectively:  $\lambda_{1,5,6}=-1, \lambda_2=-2, \lambda_{3,4}=-3$ .

$Z(A)$  has 10 eigenvalues, which are respectively:  $\lambda_{1,3,5,6,8}=0, \lambda_{2,4,7,9,10}=1$ .

All eigenvalues of  $W(A)$  are non-positive, so it can be known that the Petri net of this module is structurally bounded according to Theorem 1. All eigenvalues of  $Z(A)$  are non-negative, so the Petri net of this module is structurally repeatable according to Theorem 2. At the same time, there is 0 as an eigenvalue of  $Z(A)$ , so Theorem 3 shows that the Petri net of this module is compatible.

*Ship operating module*

By analysing the Petri net of ship operating module in *Figure 5*, it can be seen that in this module there is one output arc at most for each place, but there are two output arcs for transition of  $t_6$ . Therefore, the ship entry module is a CF net and a non-LF net.

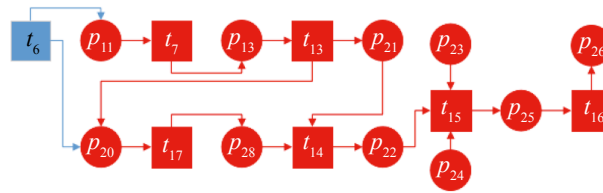

Figure 5 – The Petri net of ship operating module

Firstly, the incidence matrix  $B$  of the ship operating module is calculated according to *Formula 3*. Then,  $U(B)$  and  $V(B)$  are calculated according to *Formulas 1 and 2*, respectively. Finally,  $W(B)$  and  $Z(B)$  are calculated according to *Formulas 4 and 5*:

$$W(B) = B^T U(B) = \begin{bmatrix} 0 & 1 & 0 & 0 & 0 & 0 & 1 \\ 0 & -1 & 1 & 0 & 0 & 0 & 0 \\ 0 & 0 & -1 & 1 & 0 & 0 & 1 \\ 0 & 0 & 0 & -2 & 1 & 0 & 0 \\ 0 & 0 & 0 & 0 & -3 & 1 & 0 \\ 0 & 0 & 0 & 0 & 0 & -1 & 0 \\ 0 & 0 & 0 & 1 & 0 & 0 & -1 \end{bmatrix} \quad Z(B) = BV^T(B) = \begin{bmatrix} 1 & -1 & 1 & 0 & 0 & 0 & 0 & 0 & 0 & 0 \\ 0 & 1 & -1 & -1 & 0 & 0 & 0 & 0 & 0 & 0 \\ 1 & 0 & 2 & 1 & 0 & 0 & 0 & 0 & 0 & -1 \\ 0 & 0 & 1 & 1 & -1 & 0 & 0 & 0 & 0 & 0 \\ 0 & 0 & 0 & 0 & 1 & 0 & 0 & -1 & 0 & 0 \\ 0 & 0 & 0 & 0 & 0 & 0 & 0 & -1 & 0 & 0 \\ 0 & 0 & 0 & 0 & 0 & 0 & 0 & -1 & 0 & 0 \\ 0 & 0 & 0 & 0 & 0 & 0 & 0 & 1 & -1 & 0 \\ 0 & 0 & 0 & 0 & 0 & 0 & 0 & 1 & 0 & 0 \\ 0 & 0 & 0 & 0 & -1 & 0 & 0 & 0 & 0 & 1 \end{bmatrix}$$

Since the ship operating module is a non-LF net,  $Z(B)$  needs to be transformed according to *Formula 7*, and  $\tilde{Z}(B)$  can be obtained:

$$\tilde{Z}(B) = \begin{bmatrix} 1 & -1 & 0 & 0 & 0 & 0 & 0 & 0 & 0 & 0 \\ 0 & 1 & -1 & -1 & 0 & 0 & 0 & 0 & 0 & 0 \\ 0 & 0 & 2 & 0 & 0 & 0 & 0 & 0 & 0 & -1 \\ 0 & 0 & 0 & 1 & -1 & 0 & 0 & 0 & 0 & 0 \\ 0 & 0 & 0 & 0 & 1 & 0 & 0 & -1 & 0 & 0 \\ 0 & 0 & 0 & 0 & 0 & 0 & 0 & -1 & 0 & 0 \\ 0 & 0 & 0 & 0 & 0 & 0 & 0 & -1 & 0 & 0 \\ 0 & 0 & 0 & 0 & 0 & 0 & 0 & 1 & -1 & 0 \\ 0 & 0 & 0 & 0 & 0 & 0 & 0 & 0 & 1 & 0 \\ 0 & 0 & 0 & 0 & -1 & 0 & 0 & 0 & 0 & 1 \end{bmatrix}$$

After calculation,  $W(B)$  has 7 eigenvalues, which are, respectively:  $\lambda_1=0, \lambda_{2,3,4,7}=-1, \lambda_5=-2, \lambda_6=-3$ .

$\tilde{Z}(B)$  has 10 eigenvalues, which are, respectively:  $\lambda_{1,2,4,5,6,9,10}=1, \lambda_3=2, \lambda_{7,8}=0$ .

All eigenvalues of  $W(B)$  are non-positive, so it can be known that the Petri net of this module is structurally bounded according to *Theorem 1*. All eigenvalues of  $\tilde{Z}(B)$  are non-negative, so the Petri net of this module is structurally repeatable according to *Theorem 5*.

The coordination of the Petri net of this module is analysed by solving the  $p$ -invariant: calculate  $B^T X=0$ ,  $x_1=(0,0,0,0,0,-1,1,0,0,0)^T$ ,  $x_2=(0,0,0,0,0,1,0,1,1,0)^T$ ,  $x_3=(-1,-1,1,-2,-1,1,0,0,0,1)^T$ .

It can be seen that three P invariants are supporting all transitions, so the Petri net of the ship operating module is coordinated.

### Inner truck operation module

By analysing the Petri net of inner truck operation module in *Figure 6*, it can be seen that in this module there is one output arc at most for each place, but there are three output arcs for transitions  $t_9, t_{10}$  and  $t_{28}$ . Therefore, the inner truck operation module is a CF net and a non-LF net.





It can be seen that three P invariants are supporting all transitions, so the Petri net of the inner truck operation module is coordinated.

*Outer truck operation module*

By analysing the Petri net of outer truck operation module in Figure 7, it can be seen that in this module there are two output arcs for place  $p_{35}$ , and two output arcs for transitions  $t_{26}$ ,  $t_{27}$ . Therefore, the outer truck operation module is neither a CF net nor an LF net.

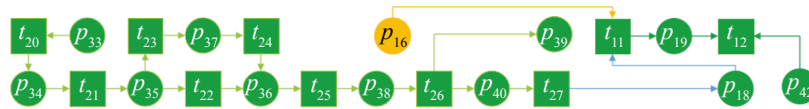

Figure 7 – The Petri net of outer truck operation module

Firstly, the incidence matrix  $D$  of the outer truck operation module is calculated according to Formula 3. Then  $U(D)$  and  $V(D)$  are calculated according to Formulas 1 and 2, respectively. Finally,  $W(D)$  and  $Z(D)$  are calculated according to Formulas 4 and 5:

$$W(D) = D^T U(D) = \begin{bmatrix} -2 & 1 & 0 & 0 & 0 & 0 & 0 & 0 & 0 & 0 & 0 & 0 \\ 0 & -2 & 0 & 0 & 0 & 0 & 0 & 0 & 0 & 0 & 0 & 0 \\ 0 & 0 & -1 & 1 & 0 & 0 & 0 & 0 & 0 & 0 & 0 & 0 \\ 0 & 0 & 0 & -1 & 1 & 1 & 0 & 0 & 0 & 0 & 0 & 0 \\ 0 & 0 & 0 & 0 & -1 & -1 & 0 & 1 & 0 & 0 & 0 & 0 \\ 0 & 0 & 0 & 0 & -1 & -1 & 1 & 0 & 0 & 0 & 0 & 0 \\ 0 & 0 & 0 & 0 & 0 & 0 & -1 & 1 & 0 & 0 & 0 & 0 \\ 0 & 0 & 0 & 0 & 0 & 0 & 0 & -1 & 1 & 0 & 0 & 0 \\ 0 & 0 & 0 & 0 & 0 & 0 & 0 & 0 & -1 & 1 & 1 & 0 \\ 0 & 1 & 0 & 0 & 0 & 0 & 0 & 0 & 1 & -1 & 0 & 0 \\ 0 & 0 & 0 & 0 & 0 & 0 & 0 & 0 & 0 & 0 & -1 & 0 \end{bmatrix} \quad Z(D)ZV^T(D) = \begin{bmatrix} 0 & 0 & -1 & 0 & 0 & 0 & 0 & 0 & 0 & 0 & 0 & 0 \\ 0 & 0 & -1 & 0 & 0 & 0 & 0 & 0 & 0 & 0 & 0 & 0 \\ 0 & 0 & 1 & 0 & 0 & 0 & 0 & 0 & 0 & 0 & 0 & 0 \\ 0 & 0 & 0 & 0 & -1 & 0 & 0 & 0 & 0 & 0 & 0 & 0 \\ 0 & 0 & 0 & 0 & 1 & -1 & 0 & 0 & 0 & 0 & 0 & 0 \\ 0 & 0 & 0 & 0 & 0 & 1 & -1 & -1 & 0 & 0 & 0 & 0 \\ 0 & 0 & 0 & 0 & 0 & 0 & 2 & 0 & -1 & 0 & 0 & 0 \\ 0 & 0 & 0 & 0 & 0 & 0 & -1 & 1 & 0 & 0 & 0 & 0 \\ 0 & 0 & 0 & 0 & 0 & 0 & 0 & 0 & 2 & -1 & -1 & 1 \\ 0 & 0 & 0 & 0 & 0 & 0 & 0 & 0 & 0 & 1 & 1 & 0 \\ 0 & 0 & 0 & 0 & 0 & 0 & 0 & 0 & -1 & 1 & 1 & -1 \\ 0 & 0 & 0 & 0 & 0 & 0 & 0 & 0 & 1 & 0 & 0 & 1 \end{bmatrix}$$

Since the outer truck operation module is a non-CF net and a non-LF net,  $W(D)$  and  $Z(D)$  need to be transformed according to Formulas 6 and 7 and  $\tilde{W}(D)$  and  $\tilde{Z}(D)$  can be obtained:

$$\tilde{W}(D) = \begin{bmatrix} -2 & 1 & 0 & 0 & 0 & 0 & 0 & 0 & 0 & 0 & 0 & 0 \\ 0 & -2 & 0 & 0 & 0 & 0 & 0 & 0 & 0 & 0 & 0 & 0 \\ 0 & 0 & -1 & 1 & 0 & 0 & 0 & 0 & 0 & 0 & 0 & 0 \\ 0 & 0 & 0 & -1 & 1 & 1 & 0 & 0 & 0 & 0 & 0 & 0 \\ 0 & 0 & 0 & 0 & -1 & 0 & 0 & 1 & 0 & 0 & 0 & 0 \\ 0 & 0 & 0 & 0 & 0 & -1 & 1 & 0 & 0 & 0 & 0 & 0 \\ 0 & 0 & 0 & 0 & 0 & 0 & -1 & 1 & 0 & 0 & 0 & 0 \\ 0 & 0 & 0 & 0 & 0 & 0 & 0 & -1 & 1 & 0 & 0 & 0 \\ 0 & 0 & 0 & 0 & 0 & 0 & 0 & 0 & -1 & 1 & 1 & 0 \\ 0 & 1 & 0 & 0 & 0 & 0 & 0 & 0 & 1 & -1 & 0 & 0 \\ 0 & 0 & 0 & 0 & 0 & 0 & 0 & 0 & 0 & 0 & -1 & 0 \end{bmatrix} \quad \tilde{Z}(D) = \begin{bmatrix} 0 & 0 & -1 & 0 & 0 & 0 & 0 & 0 & 0 & 0 & 0 & 0 \\ 0 & 0 & -1 & 0 & 0 & 0 & 0 & 0 & 0 & 0 & 0 & 0 \\ 0 & 0 & 1 & 0 & 0 & 0 & 0 & 0 & 0 & 0 & 0 & 0 \\ 0 & 0 & 0 & 0 & -1 & 0 & 0 & 0 & 0 & 0 & 0 & 0 \\ 0 & 0 & 0 & 0 & 1 & -1 & 0 & 0 & 0 & 0 & 0 & 0 \\ 0 & 0 & 0 & 0 & 0 & 1 & -1 & -1 & 0 & 0 & 0 & 0 \\ 0 & 0 & 0 & 0 & 0 & 0 & 2 & 0 & -1 & 0 & 0 & 0 \\ 0 & 0 & 0 & 0 & 0 & 0 & -1 & 1 & 0 & 0 & 0 & 0 \\ 0 & 0 & 0 & 0 & 0 & 0 & 0 & 0 & 2 & -1 & -1 & 0 \\ 0 & 0 & 0 & 0 & 0 & 0 & 0 & 0 & 0 & 1 & 0 & 0 \\ 0 & 0 & 0 & 0 & 0 & 0 & 0 & 0 & -1 & 0 & 1 & -1 \\ 0 & 0 & 0 & 0 & 0 & 0 & 0 & 0 & 0 & 0 & 0 & 1 \end{bmatrix}$$

After calculation,  $\tilde{W}(D)$  has 11 eigenvalues, which are, respectively:  $\lambda_{1,2,3,4,5,6,11}=-1, \lambda_7=0, \lambda_{8,9,10}=-2$ .

$\tilde{Z}(D)$  has 12 eigenvalues, which are, respectively:  $\lambda_{1,8,9}=0, \lambda_{2,3,4,10,11,12}=1, \lambda_5=2, \lambda_6=0.382, \lambda_7=2.618$ .

All eigenvalues of  $\tilde{W}(D)$  are non-positive, so it can be known that the Petri net of this module is structurally bounded according to Theorem 4. All eigenvalues of  $\tilde{Z}(D)$  are non-negative, so the Petri net of this module is structurally repeatable according to Theorem 5.

The coordination of the Petri net of this module is analysed by solving the p-invariant:

Calculate  $D^T X=0$ ,

$$x_1=(-0.4826,0.4826,0,-0.2762,-0.2762,-0.2762,-0.2762,-0.2762,-0.2762,0,-0.2762,0)^T$$

$$x_2=(0.5168,-0.5168,0,-0.2580,-0.2580,-0.2580,-0.2580,-0.2580,-0.2580,0,-0.2580,0)^T$$

It can be seen that two P invariants are supporting all transitions, so the Petri net of outer truck operation module is coordinated.

### 3.3 Simulation by ExtendSim

The ExtendSim software is used to simulate the container terminal handling system. ExtendSim is a visual simulation software with high flexibility and scalability. It can simulate discrete event systems and continuous systems. At the same time, it adopts a modular structure, which can greatly improve the efficiency of modelling [39].

ExtendSim is used to simulate the whole process of the container terminal handling system in this study. The construction of the simulation model for the container terminal handling system is mainly divided into the following steps: firstly, determine initial data, including the number of berths, quayside container cranes, container yard cranes, and container trucks, the ratio of the inner and outer trucks and other data. Then, the Petri net system of container terminal handling operation is used as the main logic to design the specific contents of each module according to the arrival, berthing, loading, and unloading of ships and the flow direction of containers. The construction framework of the simulation model is shown in *Figure 8*.

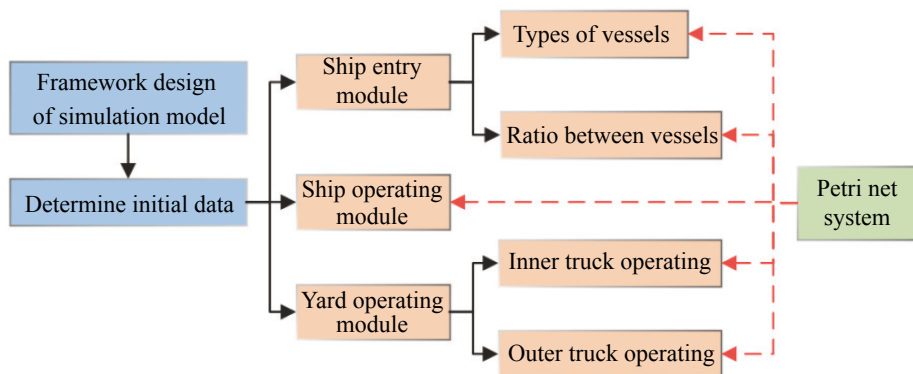

Figure 8 – Framework design of simulation model

#### Design of ship entry module

In the ship entry module, the Create is used to generate vessels, whose arrival time is by the exponential distribution with a mean of 240 min. The Equation is used to define the type of vessels. There are three types of vessels: large ships, medium ships and small ships. The detailed numbers of each type are shown in *Table 2* [40].

Table 2 – Vessels carrying capacity

Type of vessels	Average number of unloading containers	Standard deviation of unloading containers	Average number of loading containers	Standard deviation of containers
Small	90	20	100	20
Medium	180	40	200	40
Large	360	80	400	80

Meanwhile, the Set is used to make the number of ships, shipping capacity, and other relative attributes attached to the flow of ships. Then set the delay time to 60 min in the Activity, which means that the preparation time for ships from the port into the berth is 60 min. The design of this module is shown in *Figure 9*.

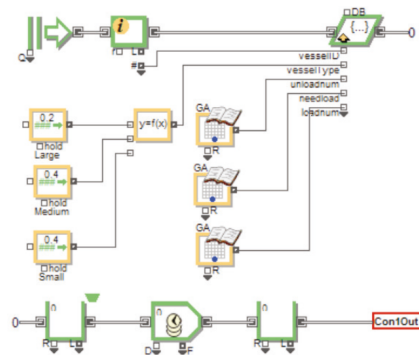

Figure 9 – Ship entry module

*Design of ship operating module*

When the ship is berthed, the Unbatch is used to release the container resources in the ship. Then vessels will be loaded or unloaded, and the handling quantity is up to the type of ship.

The unloading process is to read the number of ship unloading containers first, then line up and determine whether there are any quayside container cranes available. The Batch helps inner trucks load with containers. The inner trucks carry containers to the yard. Then the inner trucks without containers return to the wharf apron and keep working. The design of this part is just as shown in Figure 10.

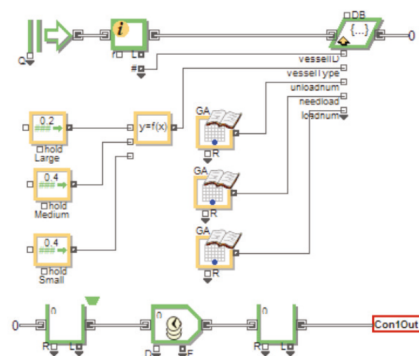

Figure 10 – Unloading containers module

The loading process is to read the number of containers required for the ship first. Then get a Gate as a switch. When it is on, the Batch packs containers and trucks up. When the trucks with containers arrive at the wharf apron, the quayside container cranes start to work until the ship is fully loaded. The design of this part is just as shown in Figure 11.

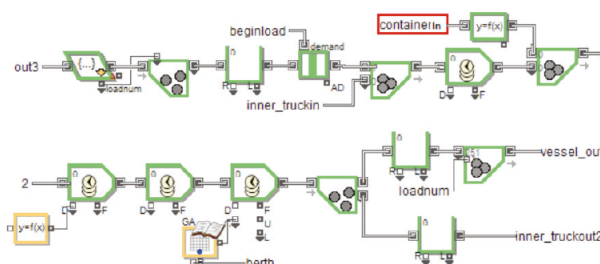

Figure 11 – Loading containers module

There is a switch module that links up the unloading process and the loading process. When the length of the queue in the loading process is 0, which means that the ship has already been fully loaded, the Gate opens. Then the number of the containers the ship needs is read. It determines whether there is a need for

loading. If there is, the Set makes attributes attached to the container, which is flowing to the loading part. If not, the ship leaves from the container terminal. The design of this part is just as shown in *Figure 12*.

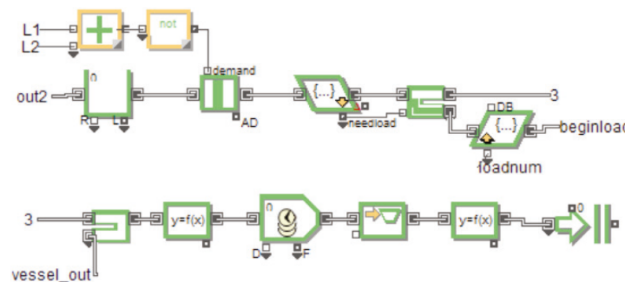

Figure 12 – Switch module

### Design of yard operating module

In this module, we make the following assumptions:

- 1) The number of container yard cranes is sufficient, and loading and unloading operations can be carried out immediately as long as there is demand.
- 2) The capacity of the yard is sufficient, and there is no competition for storage space.

The Resource Item is used to simulate the initialisation of the resource on the yard. Containers in the yard include two categories. One will stay in the yard, the other will be carried away. To count the number of containers that remain to be transferred, the Plotter is set here. The design of the module is just as shown in *Figure 13*.

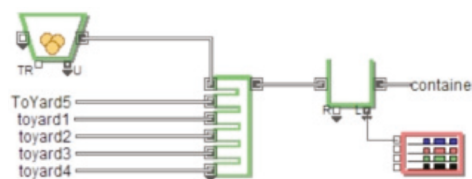

Figure 13 – Yard operating module

## 4. RESULTS

The statistical data of the ship entry module include the average waiting time, the longest waiting time, the longest queue and the average queue length of the ship. As shown in *Table 3*, the average waiting time is 1210 min, about 20 hours, and the average queue length is 4 ships, which indicates that there is a certain degree of congestion in the wharf apron. Congestion may be due to the lack of quayside container cranes, its low efficiency, or the lack of inner container trucks, or may be due to the low efficiency of the container yard crane. Those are all points where we search for ways to improve.

Table 3 – Statistics on ship entry module

Attribute	Value
Average waiting time [min]	1210
Maximum waiting time [min]	2210
Average queue length (ship)	4
Maximum queue length (ship)	6
Quantity of vessels handled (ship)	20

The physical flow of berths 1, 2, 3 and 4 consists of two categories, one is the imported containers, and the other is export containers. The specific data is shown in *Figure 14*. Berth 2 handles far more containers than the other three berths, and berth 4 handles far fewer than other berths. Although the four berths are equipped with the same machinery, there is a gap in handling capacity between the four berths which explains the port congestion to a certain degree. In fact, the quayside container cranes in the terminal will not be the same type, and the handling capacity of each quayside container crane is different. Therefore, the handling capacity of the berth corresponding to each quayside container crane is also different. But this paper simplifies this point.

In the yard operating module, the quantity of containers in the yard is dynamic. Initially, there are 100 containers, the curve in *Figure 15* vividly shows the dynamic change of containers. It can be seen that the number of containers in the container yard changes dynamically. The initial number of containers is 80 boxes. With the operation of the model, the number of containers shows a rising tendency and reaches the peak of 1800 at 3200 min. In this model, there is no way to know the utilisation of yard space, because the yard capacity is unavailable. Concerning the dynamic change curve of the container quantity, the capacity design and space planning of the yard can be made more reasonable.

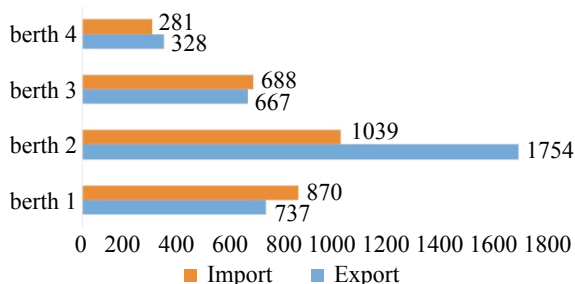

Figure 14 – The physical flow of berth

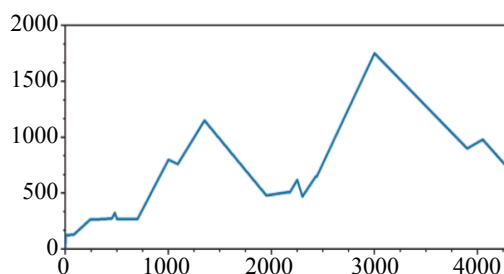

Figure 15 – Quantity of containers in the yard

## 5. DISCUSSION

The simulation results in the previous chapter show the average waiting time of ships is 1210 min, and the average queue length is 4 ships, with a certain congestion phenomenon in berths. Therefore, we optimised the model from three aspects. After optimisation, the berth handling capacity of the model was increased, and the average waiting time and average queue length of ships were reduced. The following is the specific optimisation process.

*Modify the entity parameters.* Both reducing waiting or moving times of the container trucks on the yard or improving the loading and unloading speed of the quayside container cranes and the container yard cranes can improve the work efficiency of the harbour. High speed and stability is the developmental trend of container terminal handling machinery.

In the new model, the running speed of container trucks is improved to reduce the moving time in the yard. Since the number of container yard cranes is assumed to be sufficient, container trucks can be loaded or unloaded directly at the yard. The waiting time for container trucks in the yard will not be longer with the increase in speed. Therefore, we increased the speed of container trucks by 16.7% to reach the maximum allowed speed in the container terminal. The comparison of simulation results between the original and the new model is shown in *Figure 16* and *Table 4*.

It can be seen that the average queuing time of vessels is reduced by 47.2%, the average queue length is reduced by 17.5%, and the handling capacity of the berth is improved by 9.9%. In other words, when the speed of the container truck is increased, the average waiting time of the ship is reduced greatly and the average queue length is reduced, which effectively alleviates the congestion at the berth and makes the system run more smoothly.



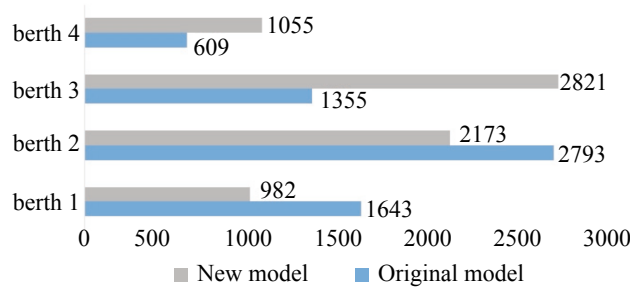

Figure 16 – Comparison 1

Table 4 – Comparison 1 of queuing data

	Original model	New model
Average waiting time [min]	1210	637.9
Average queue length (ship)	4	3.3

*Change the number of entities.* Examples are increasing the quantity of quayside container cranes and inner trucks or changing the ratio of inner trucks to outer trucks. The ratio of quayside container cranes to inner trucks, and the ratio of the inner truck to the outer truck both are key points of the problem.

In the new model, we try to improve the handling speed and reduce the average waiting time of ships by adjusting the number of inner trucks. The initial number of inner trucks was 20, and we recorded the processing data of the berths after adding 5, 10, 15, 20, 25 and 30 inner trucks, respectively. As can be seen from the data in the *Figure 17*, when the number of inner trucks is increased by 20, the physical flow of the berth is significantly increased, but if the number of inner trucks continues to be added, the physical flow of the berth is difficult to be improved due to the limitations of the number and operating efficiency of quayside container cranes. So, the optimal scenario is to add 20 inner trucks. The comparison of simulation results between the original and the new model is shown in *Figure 18* and *Table 5*.

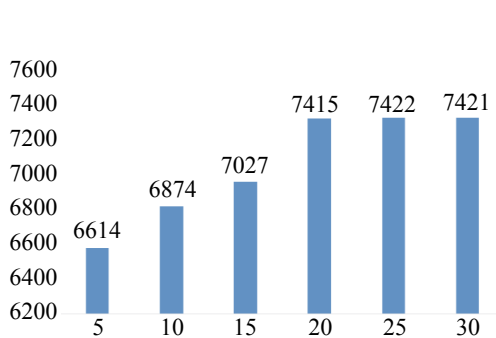

Figure 17 – Comparison about physical flow of berth

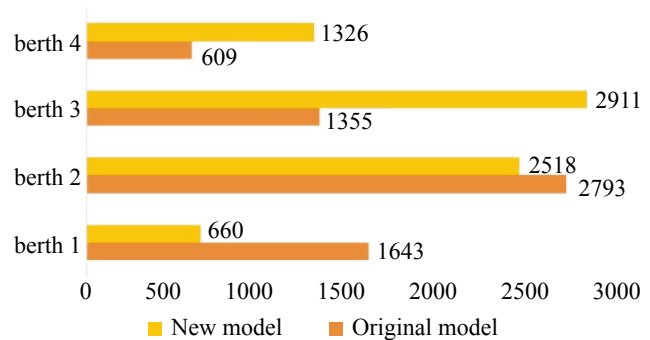

Figure 18 – Comparison 2

Table 5 – Comparison 2 of queuing data

	Original model	New model
Average waiting time [min]	1210	968.2
Average queue length (ship)	4	3.1

It can be seen that the average queuing time is reduced by 36.5%, the average queue length is reduced by 22.5%, and the handling capacity of the berth is improved by 15.9%. In other words, at the same time, the total amount of containers handled in the harbour has increased significantly and the efficiency has been greatly improved.

*Change the mode.* The mode of allocation of the quayside container cranes could change from flexible assignment to rigid assignment. Meanwhile, the mode of operation of container trucks could change from a cross-running mode to a non-cross-running mode.

In the new model, quayside container cranes are assigned rigidly, which is different from the model in the old model. The comparison of simulation results between the original and the new model is shown in Figure 19 and Table 6.

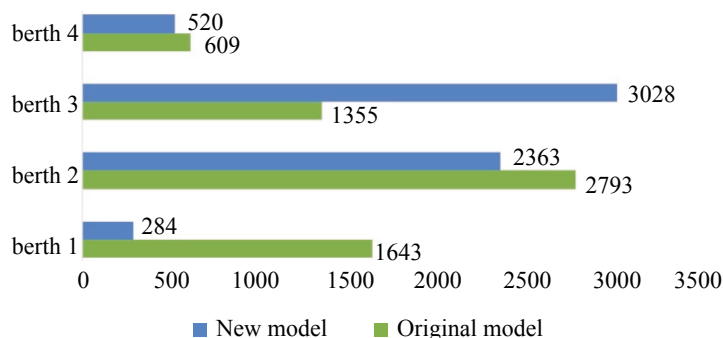

Figure 19 – Comparison 2

Table 6 – Comparison 3 of queuing data

	Original model	New model
Average waiting time [min]	1210	409.5
Average queue length (ship)	4	2.0

It can be seen that the average queuing time and the average queue length of vessels significantly decrease, but the handling capacity of the berth has decreased by 3.2%. That is, when the quayside container cranes adopt a rigid distribution mode, the waiting time of ships decreases, but the handling capacity of the port declines slightly.

## 6. CONCLUSION

This paper analyses the container terminal handling system. In the early stage of modelling, relevant literature was perused to acquaint with the conditions of correlation studies at home and abroad. Next, a Petri net was used to describe the process of the container terminal handling and the Petri net system was verified to ensure the rationality and feasibility of the loading and unloading process. Then the ExtendSim model of the container handling system was built and run. In the end, by analysing the simulation result, the following conclusions were obtained.

- 1) Improving the velocity of container trucks and reducing their running time can effectively alleviate the operating pressure in the wharf apron, which improves system operation fluency and the efficiency of container terminal handling operations.
- 2) The efficiency of the container handling system is affected by the ratio of quayside container cranes and inner trucks. When the quantity of quayside container trucks is certain, the quantity of inner trucks increases within a certain range, the average staying time of vessels decreases, and what is more, the efficiency of the container handling system improves.
- 3) Equipping berths with a different type of handling machinery corresponding with the handling capacity of berths can improve the efficiency of the container handling system, making the most use of handling machinery and reducing port operating costs.

In this paper, Petri net and ExtendSim are combined in an innovative way to design the simulation model of the container terminal handling system. However, this is based on some ideal conditions. The number of container yard cranes and yard capacity are not limited, so the problem of container storage is ignored. In the future, it is possible to make a progressive study on container location assignment in the yard and container yard crane assignment.

## ACKNOWLEDGEMENTS

This work is supported by the National Natural Science Foundation of China under Grant 51972050; Heilongjiang Provincial Natural Science Foundation of China under Grant LH2020E006.

## REFERENCE

- [1] Haralambides H. Globalization, public sector reform, and the role of ports in international supply chains. *Maritime Economics and Logistics*. 2017;19(1):1-51. DOI: 10.1057/s41278-017-0068-6.
- [2] Agra A, Oliveira M. MIP approaches for the integrated berth allocation and quay crane assignment and scheduling problem. *European Journal of Operational Research*. 2018;264(1):138-148. DOI: 10.1016/j.ejor.2017.05.040.
- [3] Barbosa F, Rampazzo P, Yamakami A, Camanho A. The use of frontier techniques to identify efficient solutions for the Berth Allocation Problem solved with a hybrid evolutionary algorithm. *Computers & Operations Research*. 2019;107(2019):43-60. DOI: 10.1016/j.cor.2019.01.017.
- [4] Yang D, Zhao Y, Yanagita T. A frame study of correlation analysis between open macroeconomics system and container throughput. *Transportation Research Procedia*. 2017;25:2784/2796. DOI: 10.1016/j.trpro.2017.05.233.
- [5] Xie G, Zhang N, Wang S. Data characteristic analysis and model selection for container throughput forecasting within a decomposition-ensemble methodology. *Transportation Research Part E: Logistics and Transportation Review*. 2017;108:160-78. DOI: 10.1016/j.tre.2017.08.015.
- [6] Notteboom T. The adaptive capacity of container ports in an era of mega vessels: The case of upstream seaports Antwerp and Hamburg. *Journal of Transport Geography*. 2016;54:295-309. DOI: 10.1016/j.jtrangeo.2016.06.002.
- [7] Haralambides HE. Gigantism in container shipping, ports and global logistics: A time-lapse into the future. *Maritime Economics and Logistics*. 2019;21:1-60. DOI: 10.1057/s41278-018-00116-0.
- [8] Song WP. *Shanghai International Shipping Research Center reported: The growth rate of container throughput at global ports rebounded to 6.5%, surpassing the pre-pandemic level*. <https://news.cnstock.com/news,bwqx-202204-4862514.htm> [Accessed 9th Nov. 2022].
- [9] Vrakas G. The effects of evolving port technology and process optimisation on operational performance: The case study of an Australian container terminal operator. *The Asian Journal of Shipping and Logistics*. 2021;37(2021):281-290. DOI: 10.1016/j.ajsl.2020.04.001.
- [10] Said GAEA, El-Horbaty EM. An optimization methodology for container handling using genetic algorithm. *Procedia Computer Science*. 2015;65(2015):662-671. DOI: 10.1016/j.procs.2015.09.010.
- [11] Msakni MK, et al. Exact methods for the quay crane scheduling problem when tasks are modeled at the single container level. *Computers and Operations Research*. 2018;99(2018):218-233. DOI: 10.1016/j.cor.2018.07.005.
- [12] Dkhil H, Yassine A, Chabchoub H. Multi-objective optimization of the integrated problem of location assignment and straddle carrier scheduling in maritime container terminal at import. *Journal of the Operational Research Society*. 2017;1-23. DOI: 10.1057/s41274-017-0184-9.
- [13] Dik G, Kozan E. A flexible crane scheduling methodology for container terminals. *Flexible Services and Manufacturing Journal*. 2017;29:64-96. DOI: 10.1007/s10696-016-9264-4.
- [14] Kizilay D, Eliiyi DT, Van Hentenryck P. Constraint and mathematical programming models for integrated port container terminal operations. In: Van Hoesve WJ. (ed.) *Integration of constraint programming, artificial intelligence, and operations research*. CPAIOR 2018. Lecture Notes in Computer Science. Springer, Cham; 2018. p. 10848.

- [15] Jonker T, et al. Coordinated optimization of equipment operations in a container terminal. *Flexible Services and Manufacturing Journal*. 2021;33:281-311. DOI: 10.1007/s10696-019-09366-3.
- [16] Zhuang ZL, et al. Optimization for integrated scheduling of intelligent handling equipment with bidirectional flows and limited buffers at automated container terminals. *Computers & Operations Research*. 2022;145(2022):105863. DOI: 10.1016/j.cor.2022.105863.
- [17] Lee LH, Chew EP, Teng S, Chen Y. Multi-objective simulation-based evolutionary algorithm for an aircraft spare parts allocation problem. *European Journal of Operational Research*. 2008;189( 2):476-491. DOI: 10.1016/j.ejor.2007.05.036.
- [18] Sun Z, Lee LH, Chew EP, Tan KC. MicroPort: A general simulation platform for seaport container terminals. *Advanced Engineering Informatics*. 2012;26(1):80-90. DOI: 10.1016/j.aei.2011.08.010.
- [19] Clausen U, Kaffka J, Meier F. CONTSIM – Container terminal management with simulation. *Procedia - Social and Behavioral Sciences*. 2012;54(2012):332-340. DOI: 10.1016/j.sbspro.2012.09.752.
- [20] He JL, Zhang WM, Huang YF. A simulation optimization method for internal trucks sharing assignment among multiple container terminals. *Advanced Engineering Informatics*. 2013;27(2013):598-614. DOI: 10.1016/j.aei.2013.08.001.
- [21] Schroër HJ, et al. Evaluation of inter terminal transport configurations at Rotterdam Maasvlakte using discrete event simulation. *Proceedings of the winter simulation conference 2014*. IEEE; 2014. p. 1771-1782. DOI: 10.1109/WSC.2014.7020026.
- [22] Abourraja MN, et al. A multi-agent based simulation model for rail-rail transshipment: An engineering approach for gantry crane scheduling. *IEEE Access*. 2017;5:13142-13156. DOI: 10.1109/ACCESS.2017.2713246.
- [23] Castilla- Rodríguez L, et al. Simulation-optimization for the management of the transshipment operations at maritime container terminals. *Expert Systems with Applications*. 2020;139:112852. DOI: 10.1016/j.eswa.2019.112852.
- [24] Muravev D, Hu H, Rakhmangulov A, Mishkurov P. Multi-agent optimization of the intermodal terminal main parameters by using AnyLogic simulation platform: Case study on the Ningbo-Zhoushan Port. *International Journal of Information Management*. 2021;57:102133. DOI: 10.1016/j.ijinfomgt.2020.102133.
- [25] Rožić T, Ivanković B, Bajor I, Starčević M. A network-based model for optimization of container location assignment at inland terminals. *Applied Sciences*. 2022;12(12):5833. DOI: 10.3390/app12125833.
- [26] Alessandri A, et al. Model-based feedback control of container handling in intermodal terminals. *IFAC Proceedings Volumes*. 2006;39(12):531-536. DOI: 10.3182/20060829-3-NL-2908.00092.
- [27] Fu Q, Zhong CY. Modeling and simulation of container port logistics system based on HTCPN. *Logistics Technology*. 2014;33(05):419-421+429. DOI: 10.3969/j.issn.1005-152X.2014.03.133.
- [28] Cavone G, Dotoli M, Epicoco N, Seatzu C. Intermodal terminal planning by Petri Nets and Data Envelopment Analysis. *Control Engineering Practice*. 2017;69(2017):9-22. DOI: 10.1016/j.conengprac.2017.08.007.
- [29] Si YJ. *Study of berth and quay crane assignment and container truck scheduling problem*. PhD thesis. Hebei University of Technology; 2017.
- [30] Facchini F, Digiesi S, Mossa G. Optimal dry port configuration for container terminals: A non-linear model for sustainable decision making. *International Journal of Production Economics*. 2020;219(2020):164-78. DOI: 10.1016/j.ijpe.2019.06.004.
- [31] Yuan CY. *Principle of Petri net*. Beijing: Electronics Industry; 1998.
- [32] Yu W, et al. Modeling and analysis of medical resource allocation based on Timed Colored Petri net. *Future Generation Computer Systems*. 2020;111:368-74. DOI: 10.1016/j.future.2020.05.010.
- [33] Flores Geronimo M, et al. A multiagent systems with Petri Net approach for simulation of urban traffic networks. *Environment and Urban Systems*. 2021;89:101662. DOI: 10.1016/j.compenvurbsys.2021.101662.
- [34] Jensen K, Kristensen LM. *Coloured Petri Nets: Modelling and validation of concurrent systems*. Berlin: Springer; 2009.
- [35] Yuan JM. *Petri Net modeling and functional analysis for reliability of complex systems*. Beijing: National Defense Industry; 2011.

- [36] Guo ZF. *Optimization of outbound containers collection and shipment in container terminal with considering energy consumption analysis*. PhD thesis. Dalian Maritime University; 2019.
- [37] Teruel E, Silva M. Structure theory of equal conflict systems. *Theoretical Computer Science*. 1996;153(1-2):271-300. DOI: 10.1016/0304-3975(95)00124-7.
- [38] Liao JJ, Wang MZ. Eigenvalues of incidence matrices applied to the analysis of Petri net structure. *Journal of Applied Science*. 2010;28(4):417-423. DOI: 10.3969/j.ssn.0255-8297.2010.04.015.
- [39] Alodhaibi S, Burdett RL, Yarlalagadda PKDV. Impact of passenger-arrival patterns in outbound processes of airports. *Procedia Manufacturing*. 2019;30:323-30. DOI: 10.1016/j.promfg.2019.02.046.
- [40] Qin TB, Wang YF. *Application oriented simulation modeling and analysis with ExtendSim*. Beijing: Tsinghua University; 2011.

杜丹丰<sup>1</sup>, 刘甜甜<sup>2</sup>, 郭纯<sup>3</sup>

<sup>1</sup> ddf72@nefu.edu.cn, 东北林业大学, 交通学院

<sup>2</sup> 17737405280@163.com, 东北林业大学, 交通学院

<sup>3</sup> 1450720698@qq.com, 美云智数科技有限公司, 自动化产品研发中心

#### 基于Petri网和ExtendSim的集装箱码头装卸系统分析

##### 摘要

集装箱码头装卸系统在海运中起着重要的作用, 如何提高其作业效率是我们面临的重大挑战。因此, 本文提出了一种将PETRI网与仿真工具相结合的分析方法。首先, 根据集装箱码头装卸过程的内在逻辑, 将集装箱码头装卸系统抽象为PETRI网系统。其次, 计算关联矩阵的特征值来对PETRI网系统进行有效性分析。然后利用EXTENDSIM软件对PETRI网系统进行仿真。结果表明, 优化后的泊位处理能力得到了明显提高。利用PETRI网和仿真工具对集装箱码头系统进行分析是本文的创新之处, 也是最重要的部分。因为PETRI网与仿真相结合不仅可以保证模型的可靠性, 而且可以更直观地对集装箱码头装卸系统进行优化。

##### 关键字

集装箱码头; 装卸系统; Petri网; 关联矩阵; 特征值计算; 仿真