

H⁻ AND He ION SOURCE FOR TANDEM ACCELERATOR

S. Fazinic, T. Tadic, L. Kukec, V. Valkovic
Ruder Boskovic Institute, Zagreb

The 6 MV Tandem Electrostatic Accelerator at the "Ruder Boskovic" Institute went into operation in 1987. Negative ion source is essential part of such an accelerator. Negative ion sources installed with tandem accelerator at "Ruder Boskovic" Institute are duoplasmatron with exchange canal and sputtering ion source (installation in progress). Duoplasmatron is used mostly for production of H⁻ beams. Modification of donor canal, for production of He⁻ ions, is in progress. Tantalum filament is replaced with directly heated lanthanum hexaboride filament. It is expected that the source lifetime of about 100 hours will be increased several times with the addition of that new filament.

1. Duoplasmatron

A schematic diagram of the ion source and its associated electrical circuits is shown in fig. 1. Arc space in a duoplasmatron (fig. 2) is formed by an anode with a very small ion-emission hole on the tantalum plate, a cathode to emit thermal electrons and an intermediate electrode between them, which is cone shaped to narrow the arc from the cathode to the anode, and which is magnetized by a solenoid coil at its root to make an intense axial magnetic field from the tip onto the anode for focusing the arc. The mild steel intermediate electrode is fitted with a tantalum cap to reduce erosion. It's internal diameter is 4

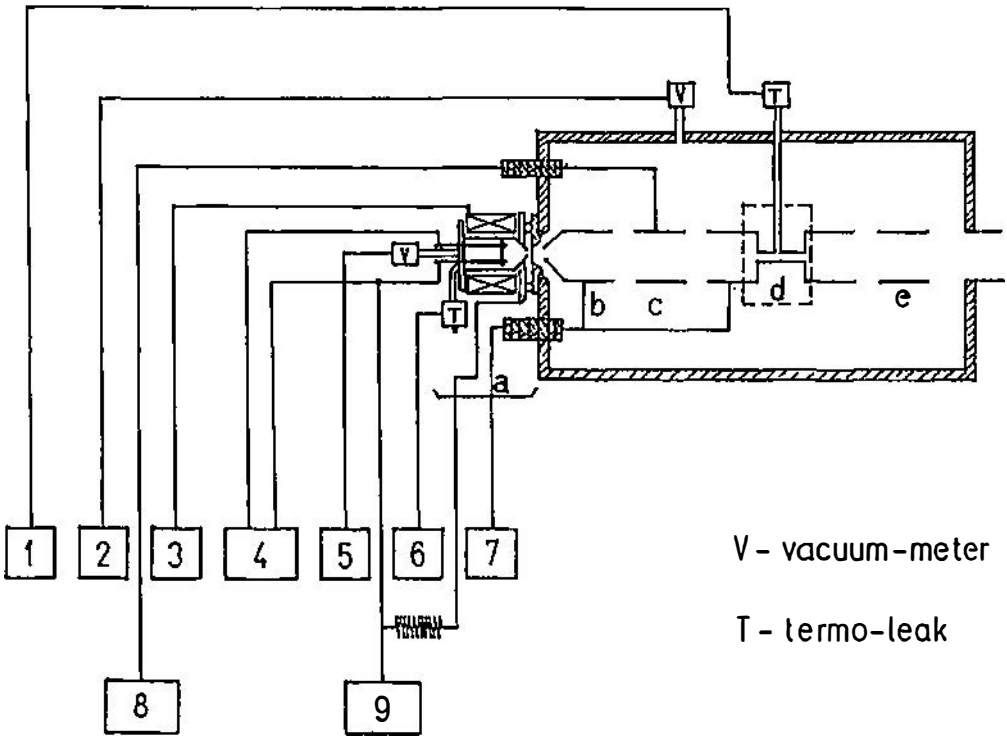

1. A schematic diagram of the ion source and its associated electrical circuit

a-duoplasmatron, b-extraction electrode, c-focus electrode, d-donor canal, e-ground electrode

1. Thermo-leak power supply, 2. Penning gauge, 3. Solenoid current power supply, 4. Filament current power supply, 5. Pirani gauge, 6. Thermo-leak power supply, 7. 30 kV extraction voltage power supply, 8. 10 kV focus electrode voltage power supply, 9. Arc voltage power supply

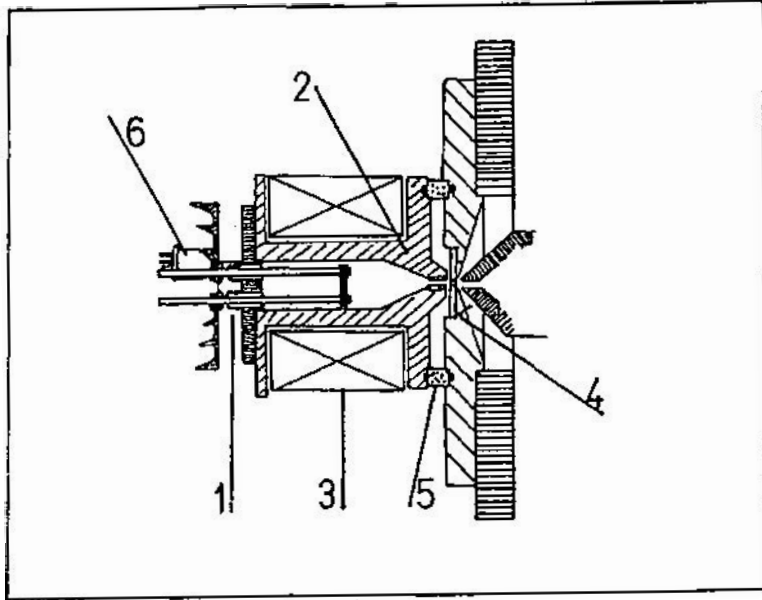

2. A schematic diagram of the duoplasmatron source with LaB_6 filament

- 1. Filament holder with LaB_6 filament, 2. Intermediate electrode, 3. Solenoid magnet, 4. Anode with emission hole, 5. Ceramic insulator, 6. Pirani gauge

mm. There is a double arc constriction due to the intermediate electrode, which results in the dense and stable plasma with a high efficiency of gas consumption. The mild steel anode has an anode insert which is of copper (for better heat exchange), fitted with a tantalum with a ion emission hole . It's diameter is 0.5 mm.

The source lifetime was limited by the evaporation rate of the 1 mm diameter tantalum filament. From the published data [1] the evaporation rate ($\text{g}/\text{cm}^2/\text{s}$) of tantalum and tungsten are both two orders of magnitude higher than that of LaB_6 which means that the lifetime of a LaB_6 filament (which depends largely on the evaporation rate) should be much larger than that of the tungsten or tantalum filament.

A filament cathode operating in a gas discharge is constantly being bombarded by ions. If the rate of sputtering of the filament material by the positive ions is high, then the lifetime of the filament will also be limited. The sputtering rate of LaB_6 and tungsten have been compared under the same environment by Kudinsteva et all [2]. The loss in weight for the tungsten sample is approximately ten times higher than the LaB_6 . Since tungsten is about four times heavier than LaB_6 , the volume of LaB_6 material sputtered away by the ions is still a factor 2.5 less than that of the tungsten.

When heated to a temperature of 1400°K or higher, LaB_6 is a copious emitter of electrons. The maximum emitted current density is given approximately by the Richardson Dushman equation

$$J_{\max} = AT^2 \exp(-e\phi/kT) \quad [\text{A/cm}^2] \quad (1)$$

where A is Richardson's constant, T is the cathode temperature in degrees kelvin, $e\phi$ is the work function in electron volts, k is the Boltzman constant. From eq. (1) it can be seen that the normal operating temperature for the LaB_6 cathode is much lower than those of tantalum or tungsten. At a given filament temperature, the emission current density for LaB_6 is two orders of magnitude higher than that of tantalum and tungsten (for LaB_6 $A=30 \text{ A/cmdeg}$, $e\phi = 2.76 \text{ eV}$, for $T= 1600 \text{ K}$ emission current density is 0.2 A/cm^2 ; for tungsten $A= 70 \text{ A/cm}^2\text{deg}^2$, $e\phi= 4.55 \text{ eV}$, emission density of 0.2 A/cm^2 is given if a temperature of the emitter is $2500 \text{ }^\circ\text{K}$).

LaB_6 filament has been tested in duoplasmatron ion source. The filament (strip $1.5 \text{ mm} \times 3 \text{ mm} \times 15 \text{ mm}$, total surface area $\approx 1.4 \text{ cm}^2$) was mounted on the mild steel holders. Since LaB_6 attacks metals like mild steel, copper or molybdenum, a filament was mounted with a piece of rhenium foil in between (LaB_6 don't attacks rhenium), as shown in fig. 1. It has operated more than 300 hours until now, with an arc voltage of 140 V and an arc current of 0.8 A. The heater current required was about 50 A. The plasma is very stable and no adjustments has to be made to the arc or heater power supply during the discharge process.

2. Extraction system

The components of the extraction system are: an expansion canal in which the plasma expands and into which electric field

cannot penetrate, an expansion cone in which the plasma spreads out to form a broad concave surface, a focus electrode for focusing the beam of positive ions to exchange canal, extract electrode for positive ions, electrode with exchange canal, and electrode for extraction of negative ions into accelerator. The use of a focus electrode has the advantage that the donor canal can be of smaller bore which minimize the gas or vapor flow. However, the lens introduces some aberrations and degrades the brightness of the positive ion source.

From plasma in the expansion cone positive ions are extracted by electrostatic field. The behaviour of the beam in the region between the extract electrode and the plasma surface is governed by Poisson equation $\nabla^2 \phi = -\rho e / \epsilon$ where ρ is the total (ion and electron) space charge density, so that Poisson equation can be written [3] as

$$\nabla^2 \phi = - \frac{e}{\epsilon_0} \left[n_i - n_{e0} \exp \left(-e \cdot \frac{\phi_0 - \phi}{kT_e} \right) \right].$$

The electron space charge term on the right hand side of the equation corresponds to Maxwellian distribution of electron energies with a temperature T_e and density n_{e0} in the center of the plasma; the potential ϕ is lower (decelerating for electrons) than the potential ϕ_0 in the unperturbed plasma. The sheath edge is assumed to be the ion emitting surface. At this position the plasma is still neutral $n_i = n_e$.

Current density j from source, potential difference U between

extraction electrode and plasma sheath edge, and distance d between extraction electrode and sheath edge are connected as:

$$d^2 \approx \epsilon_0 \cdot \sqrt{\frac{2e}{m_i}} \cdot \frac{U^{3/2}}{j}$$

3. Donor Canal

The H^- beam is formed by charge exchange in H_2 gas. This process is known to have a peak cross section for a H^+ energy in the region of 12 keV [4]. Most of the beam emerges from the donor medium as neutrals or positive ions but generally up to 1% emerges as a negative ions (at 12 keV about 2% ; at 30 keV about 1%).

It is planned to install new exchange canal for He^- production, in which He^- will be formed by charge exchange in lithium vapor [5]. This process is known to have a peak cross section for a He^+ energy in the region of 20 keV. The lithium vapor diffuses from the lithium oven into a long tapered canal, the whole unit being surrounded by a heat shield.

The donor canal defines the maximum emittance of the negative ion beam, which should match the acceptance of the tandem stripper. The donor canal is followed by a cylindrical electrostatic lens.

The method has the advantage that if donor canal is at a negative potential the positive ion source can be at ground potential and the emerging negative ions on returning to ground potential have been accelerated twice. The additional energy is a

distinct advantage for tandem injection.

R E F E R E N C E S

- [1] Walter H. Kohl, Handbuck of Materials and Techniques for Vacuum Devices (Reinhold, New York, 1967)
- [2] G. A. Kudintva, A. I. Mel'inkov, A. V. Morozov, B. P. Nikonov, Termoelectronije Katody (Energia, Moscow, 1966) Sec. 5 , p309.
- [3] Design for the Preinjector for the CERN RFQ2 Project", Ch. Hill, K. Prelec and M. Weiss, CERN/PS/HI 88-72
- [4] S. K. Allison, Rev. Mod. Phys. 30 , (1958) 1137
- [5] S. Berger, F. Dworschak, Nucl. Instr. Meth. A268, (1984)470