

STUDY OF DEGRADATION PROCESSES OF SILVER MIRRORS BY METHOD OF LIGHT SCATTERING

A. ANĐONOVSKI, S. BAHČEVANĐIZEV, D. GERŠANOVSKI AND B. VELJANOSKI

Institute of Physics, Faculty of Science, P. O. Box 162, Skopje

A B S T R A C T

The time evolution of the hologram of the light scattered by the surface of silver mirrors which are chemically deposited on glass substrate has been investigated.

The mirrors are treated within an atmosphere enriched by oxygen, carbon dioxide, sulfur dioxide and 100% humidity. The intensity of the scattered light for the corresponding polarization per unit solid angle is related to the optical and surface parameters of the mirrors by the known theoretical relations [1,2]. For determination of the intensity of the light scattered by a mirror with given optical and surface parameters, the theoretical relations were programmed by computer.

1. Introduction

The intensity of the light scattered per unit solid angle by the thin film, measured in incident plane ($\phi=0$), according to the vector theory of light scattering from mirror surface, is given by [3]

$$\frac{1}{I_0} \frac{dI}{d\Omega} = \frac{16\pi^2}{\lambda^4} \cos\theta_0 \cos^2\theta |1-\varepsilon|^2 \left\{ \frac{|x_\theta|^2}{|q'+q\varepsilon|^2} + \frac{|x_\phi|^2}{|q'+q_0|^2} \right\} \varepsilon_1(|\vec{k}-\vec{k}_0|) \quad (1)$$

where

$\varepsilon_1(|\vec{k}-\vec{k}_0|)$ - is the spectral density function of the micro-roughness of mirror surface;

I_0 - is the intensity of incident monochromatic light of wave length λ ;

$\frac{dI}{d\Omega}$ is the partial intensity of scattered light per unit solid angle ($d\Omega = \sin\theta d\theta d\phi$) scattered into direction (θ, ϕ) , Fig. 1;

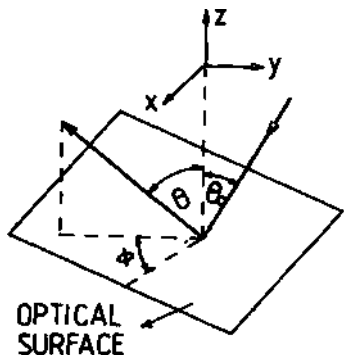

Fig. 1

θ_0 - is the incident polar angle in incident x-y plane;

θ ; ϕ - are polar angle and azimuth angle of the scattered light respectively;

ϵ - is the dielectric constant of the layer ($\epsilon = N^2$; $N = n - ik$ - complex refractive index of a material of the layer);

\vec{k} ; \vec{k}_0 - are the wave vectors of the scattered and incident light respectively;

ϕ' is the angle between the vector of incident electric field of the incident monochromatic light and the incident plane;

$\phi' = 0$ - incident electric field vector is parallel to the plane of incidence, i.e. the incident and scattered light are horizontally polarized (H_h);

$\phi' = \pi/2$ - the incident and scattered light have vertically polarization with respect to the plane incidence;

In this case χ_θ and χ_ϕ are expressed by:

-for H_h component ($\phi' = 0$)

$$\chi_\theta = \frac{(q'q_0 - kk_0\epsilon)}{q'_0 + q_0\epsilon} \quad (2)$$

-for V_v component ($\phi' = \pi/2$)

$$\chi_\phi = - \left(\frac{2\pi}{\lambda}\right)^2 \frac{1}{q'_0 + q} \quad (3)$$

2. Experiment

The measurements of the intensity of the light scattered by the mirrors were done by Brice - photometer, M - 2000 (USA). The schema of the measurements is given on Fig 2. The measurements

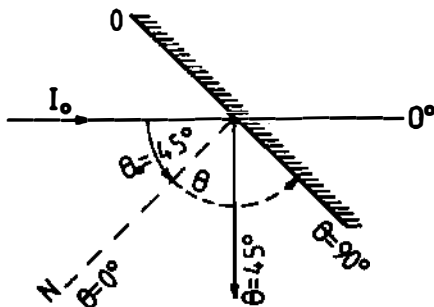

Fig. 2

0 - mirror; I_0 - intensity of the incident light; N - normal of mirror; θ_0 - incident angle; θ - scattering angle.

of the intensity of the light by the mirror are made by the same sensitivity of the photometer with monochromatic light ($\lambda=546$ nm) with vertical and horizontal polarization of the light within the angle $0^\circ \leq \theta \leq 85^\circ$. The logarithm of intensity of the polarized light, $I_{\theta, H}$ and $I_{\theta, V}$, obtained from the measurements are related to the optical and surface parameters of the mirrors by the following relations: /4/

$$\log I_{\theta, H} \cos \theta = \log \frac{16\pi^2}{\lambda^4} \cos \theta_0 \cos^2 \theta |1-\varepsilon|^2 \left[\frac{|\chi_\theta|^2}{|q'+q_0|^2} \right] \varepsilon_l(|\vec{k} - \vec{k}_0|) \quad (4)$$

$$\log I_{\theta, V} \cos \theta = \log \frac{16\pi^2}{\lambda^4} \cos \theta_0 \cos^2 \theta |1-\varepsilon|^2 \left[\frac{|\chi_\phi|^2}{|q'+q_0|^2} \right] \varepsilon_l(|\vec{k} - \vec{k}_0|) \quad (5)$$

where χ_θ and χ_ϕ are given by the (2) and (3).

The intensity of the light scattered by mirrors was calculated for silver layer of $n = 0.2$ and $k = 3.4$.

It is taken into account the surface microroughness of mirrors have 4 different correlation length (σ_{1l}) to which belong 4 different square roots of the average value of the microroughness (σ_{1l}). For such surface the spectral density function of microroughness used in theoretical calculations is given by

$$\begin{aligned} \varepsilon(|\vec{k} - \vec{k}_0|) = & \pi [\sigma_{11}^2 \sigma_{11}^2 \exp(-|\vec{k} - \vec{k}_0|^2 \sigma_{11}^2 / 4) + \\ & + \sigma_{12}^2 \sigma_{12}^2 \exp(-|\vec{k} - \vec{k}_0|^2 \sigma_{12}^2 / 4) + \sigma_{13}^2 \sigma_{13}^2 \exp(-|\vec{k} - \vec{k}_0|^2 \sigma_{13}^2 / 4) + \\ & + \sigma_{14}^2 \sigma_{14}^2 \exp(-|\vec{k} - \vec{k}_0|^2 \sigma_{14}^2 / 4)] \quad (6) \end{aligned}$$

The silver mirrors are obtained by hemical deposition to clean glass plates. The treatment for given time interval in the atmosphere of O_2 , CO_2 , and SO_2 was done in exicators.

3. Results and discussion

The first measurement were made immediately after preparation, and the others after given time interval during their treatment.

The following figures are show the obtained experimental results and optimal theoretical curves of the first and fourth measurement for some of the investigated mirrors.

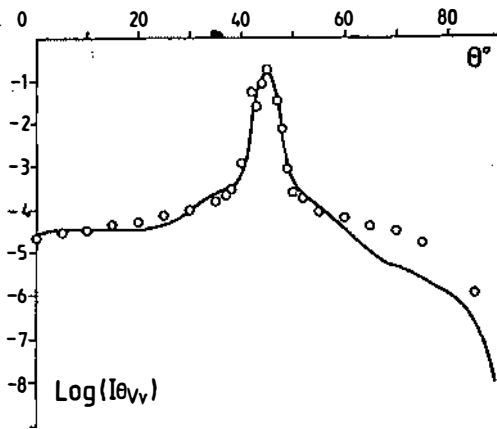

Fig. 3

Fig. 3. Mirror in 5% atmosphere of CO_2 and 100% humidity.

(o o o o) - experimental curve of first measurement on 12.05.1987:

(—) - optimal theoretical curve for:

$\delta_{11} = 1$ nm

$\delta_{11} = 100$ nm; $\delta_{12} = 0.2$ nm;

$\delta_{12} = 100$ nm; $\delta_{13} = 0.5$ nm;

$\delta_{13} = 1000$ nm; $\delta_{14} = 1.8$ nm;

$\delta_{14} = 6000$ nm.

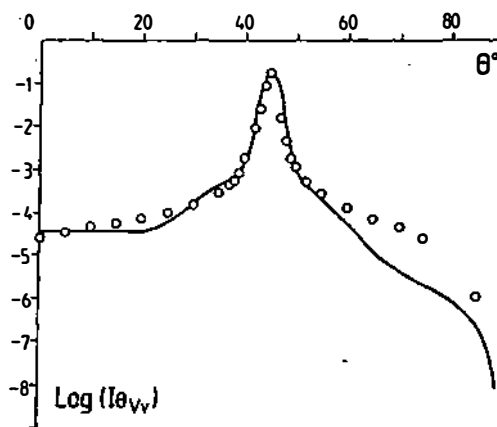

Fig. 4

Fig. 4. Mirror in 5% atmosphere of CO_2 and 100% humidity.

(o o o o) - experimental curve of fourth measurement on 23.11.1987:

(—) - optimal theoretical curve for:

$\delta_{11} = 1$ nm

$\delta_{11} = 100$ nm; $\delta_{12} = 0.2$ nm;

$\delta_{12} = 100$ nm; $\delta_{13} = 0.7$ nm;

$\delta_{13} = 1000$ nm; $\delta_{14} = 2$ nm;

$\delta_{14} = 5300$ nm.

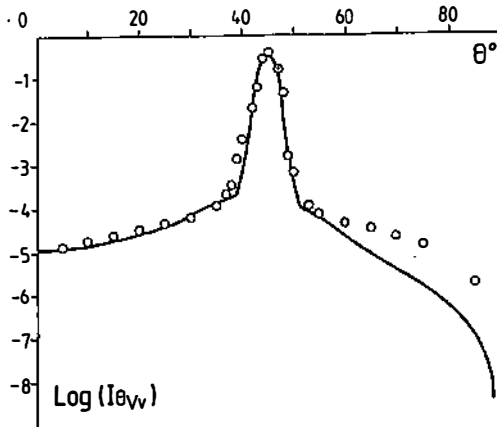

Fig. 5

Fig. 5. Mirror in 5% atmosphere of CO_2 and 100% humidity.

(o o o o) - experimental curve of first measurement on 10.06.1987:

(—) - optimal theoretical curve for:

$\delta_{11} = 0.6 \text{ nm}$
 $\delta_{12} = 100 \text{ nm}; \delta_{13} = 0.3 \text{ nm};$
 $\delta_{14} = 500 \text{ nm}; \delta_{15} = 0.3 \text{ nm};$
 $\delta_{16} = 1000 \text{ nm}; \delta_{17} = 2.7 \text{ nm};$
 $\delta_{18} = 6000 \text{ nm}.$

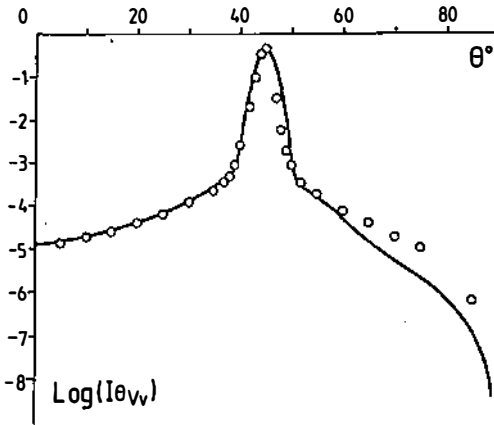

Fig. 6

Fig. 6. Mirror in 5% atmosphere of CO_2 and 100% humidity.

(o o o o) - experimental curve of fourth measurement on 23.11.1987:

(—) - optimal theoretical curve for:

$\delta_{11} = 0.6 \text{ nm}$
 $\delta_{12} = 100 \text{ nm}; \delta_{13} = 0.4 \text{ nm};$
 $\delta_{14} = 500 \text{ nm}; \delta_{15} = 0.5 \text{ nm};$
 $\delta_{16} = 1000 \text{ nm}; \delta_{17} = 3.4 \text{ nm};$
 $\delta_{18} = 5000 \text{ nm}.$

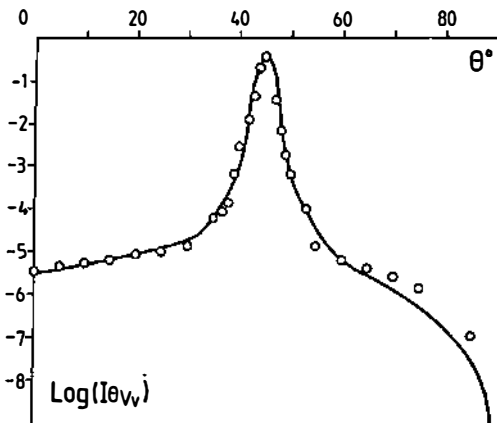

Fig. 7

Fig. 7. Mirror in 0.5% atmosphere of SO_2 and 100% humidity.

(o o o o) - experimental curve of first measurement on 9.06.1987:

(—) - optimal theoretical curve for:

$\delta_{11} = 0.3 \text{ nm}$
 $\delta_{12} = 100 \text{ nm}; \delta_{13} = 0.2 \text{ nm};$
 $\delta_{14} = 500 \text{ nm}; \delta_{15} = 0.4 \text{ nm};$
 $\delta_{16} = 1800 \text{ nm}; \delta_{17} = 3 \text{ nm};$
 $\delta_{18} = 6000 \text{ nm}.$

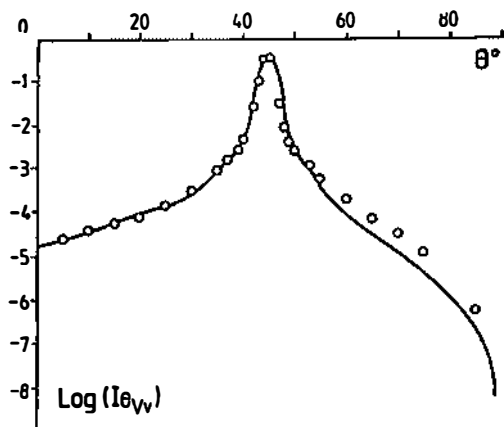

Fig. 8

Fig. 8. Mirror in 0.5% atmosphere of SO_2 and 100% humidity.

(o • o • o) - experimental curve of fourth measurement on 24.11.1987:

(- - -) - optimal theoretical curve for: $\delta_{11} = 0.65 \text{ nm}$

$\delta_{12} = 100 \text{ nm}$; $\delta_{13} = 0.65 \text{ nm}$;

$\delta_{14} = 500 \text{ nm}$; $\delta_{15} = 1 \text{ nm}$;

$\delta_{16} = 1400 \text{ nm}$; $\delta_{17} = 3 \text{ nm}$;

$\delta_{18} = 5500 \text{ nm}$.

The degradation processes of mirrors depend on the manner of preparation, and also on protection. They are the most intensive in the atmosphere with SO_2 and 100% humidity.

REFERENCES

- /1/ P. Beckmann and A. Spizzichino, "The Scattering of Electromagnetic Waves from Rough Surface", (Pergamon Press, Oxford, London, New York, Paris, 1963).
- /2/ J. Elson and H. Bennet, Opt. Eng. **18**, 116 (1979).
- /3/ J. Bennet, Thin Solid Films, **123**, 27 (1984).
- /4/ J. Elson, J. Rahn and J. Bennet, Applied Optics, Vol. 19, No. 5, 669 (1980).