

Received: 01.10.2025.  
Reviewed: 31.10.2025.  
Accepted: 03.11.2025.

Electronic collection of papers of the  
Faculty of Civil Engineering University of Mostar

Professional paper

<https://doi.org/10.47960/2232-9080.2025.30.15.49>

ISSN 2232-9080

## Load testing of the Drivuša bridge

**Marino Jurišić, Ph.D.**

University of Mostar, Faculty of Civil Engineering, Architecture, and Geodesy  
marino.jurismic@fgag.sum.ba

**Mladen Kustura, Ph.D.**

University of Mostar, Faculty of Civil Engineering, Architecture, and Geodesy  
mladen.kustura@fgag.sum.ba

**Goran Šunjić, Ph.D.**

University of Mostar, Faculty of Civil Engineering, Architecture, and Geodesy  
goran.sunjic@fgag.sum.ba

**Abstract:** This paper details the static and dynamic proof load testing of the Drivuša bridge near Zenica on Corridor Vc. It includes a description of the bridge structure and the testing methodology. The measurement process and the equipment utilized are presented. The final section provides the measurement results and their comparison with the theoretically calculated values. It has been determined that the measured results correlate well with the numerical calculations.

**Key words:** bridges, load test, oscillation frequencies, displacements, stresses

## Ispitivanje probnim opterećenjem mosta Drivuša

**Sažetak:** Rad prikazuje statičko i dinamičko ispitivanje probnim opterećenjem mosta Drivuša u blizini Zenice na koridoru Vc. Daje se opis konstrukcije mosta, kao i načina ispitivanja. Prikazan je proces mjerenja, kao i oprema koja je korištena za mjerenje. Na kraju su dani rezultati mjerenja, sa usporedbom sa računskim vrijednostima. Utvrđeno je da se mjereni rezultati dobro slažu sa računskim pretpostavkama.

**Ključne riječi:** mostovi, ispitivanje probnim opterećenjem, frekvencije osciliranja, pomaci, naprezanja

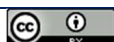

## 1. INTRODUCTION

This paper presents the results of load testing of the Drivuša bridge. The bridge is located on Corridor Vc (Drivuša-Klopče section) and spans the Bosna River (Figures 1 and 2). The contractor was Hering d.d. Široki Brijeg [1].

The load testing was performed in accordance with standard U.M1.046 from 1984, which was derived from the JUS standard [2] and is currently valid in Bosnia and Herzegovina. This standard requires that the effect of the test load must correspond to the effect of the moving load used in the static analysis [3].



Figure 1. - Bridge location on Corridor Vc



Figure 2. - The Drivuša bridge

In accordance with the applicable regulations, load testing of bridges is one of the requirements for technical inspection and issuance of an operating permit, and it applies to road bridges with spans greater than 15 meters and railway bridges with spans greater than 10 meters. The load testing of the Drivuša bridge was carried out by staff of the Faculty of Civil Engineering, Architecture and Geodesy, University of Mostar. The testing determines the behavior of the structure when subjected to specific static and dynamic loads prescribed by the design [4].

## 2. DESCRIPTION OF THE BRIDGE STRUCTURE

The Drivuša bridge is located at the beginning of the Drivuša - Klopče section, near the Drivuša interchange. It was designed as two separate structures, the left and right bridges, which extend from chainage KM 0+534.00 to chainage KM 1+189.00. The length of the left bridge is 652.30 m, and the right bridge 657.70 m, measured along the central axis of the bridge.

Horizontally, the bridges are situated in a constant curve with a radius of 1,800 m. Vertically, they begin with a constant curve and continue with a constant longitudinal gradient. Structurally, the bridges are continuous frames with 17 spans and 18 supports. Piers S5, S6, S7, and S8 are monolithically connected to the superstructure, while the other piers and abutments are equipped with bearings.

Left bridge spans:

$$34.855+(10\cdot 39.835)+(2\cdot 34.855)+(3\cdot 39.835)+29.876=652.30 \text{ m}$$

Right bridge spans:

$$35.144+(10\cdot 40.165)+(2\cdot 35.14)+(3\cdot 40.165)+30.12=657.70 \text{ m}$$

The superstructure is a prestressed box girder extending over 17 spans and resting on 18 supports. The cross section is a trapezoidal box 13.76 m wide and 3.00 m high. The cantilevers are 3.50 m long with a thickness of 25 cm at the free end and 55 cm at the fixed end at the web. The webs are 50 cm thick and are set back 55 cm at the bottom. The bottom slab has a thickness of 25 cm, and is thickened to 60 cm at the web connection. The top slab has a thickness of 25 cm, and is thickened to 55 cm at the web connection. Longitudinally, when approaching the supports, the bottom slab is thickened to 60 cm. The webs on the piers are thickened to 1.30 m, and the webs on the abutments are thickened to 1.80 m. In this way, at each support a 3.00 m long cross beam is formed with an opening intended for the passage of internal formwork and staff responsible for inspection and maintenance of the structure.

The piers have a circular cross section with a diameter of 2.70 m, with a widened pier head to accommodate the bearings. Piers S5-S7, S9, S11-S14 have shallow foundations on spread footings. The other piers are founded on 6 piles with a diameter of 1.20 m. Abutments U1 and U2 are common to the left and right bridges and are founded on piles. Piers S5-S8 are monolithically connected to the superstructure, while the other piers and abutments are equipped with longitudinally movable bearings.

The abutments have thin side and front walls, as well as supports for transition slabs. The side walls have openings for easier access to the abutment and expansion joint. The bearing seats of the abutments are inclined and equipped with gutters and drainage channels. The foundation on piles was carried out on the basis of geotechnical study G31.

The concrete classes specified for the structural elements are:

Superstructure: C40/50

Piers and abutments: C30/37

Piles: C30/37

Spread footings: C30/37

Transition slabs: C25/30

The structure is reinforced with reinforcing steel B500 B, and prestressed with prestressing steel Y1860S7.

The superstructure of the Drivuša bridge was constructed in 17 phases. The concreting breaks were made at 0.25·L of the span to reduce the unfavorable effects of the construction phases of adjacent spans.

The girder was constructed using the "span by span" method using the Movable Scaffolding System (MSS). This technology implies that the formwork is supported by a scaffold consisting of a rear support, a front support, a main girder, hangers, a front nose, a central launching support girder and a front leg. When launched, the MSS carries all elements of the formwork with it. It is necessary to prepare supports because the front nose rests on a pier, and the rear

part of the MSS rests on an already constructed element of the superstructure. This specific MSS is of the Overhead type, which means that the main girder is above the superstructure. This type provides less clearance below the structure than Underhead systems, where the main girder is below the superstructure.

### 3. TESTING PROGRAM

Load testing of bridges is a key step in the process of verifying the constructed structure. Its fundamental role is to verify the behavior of the Drivuša structure under static and dynamic traffic loads for compliance with design requirements, and to assess the quality of work and the ability of the structure to safely bear the designed load. In accordance with applicable rules and standards, the effect of the test load must correspond to a certain extent to the effect of the mobile load that was applied in the static calculation.

Since the static analysis uses standard loads prescribed for road bridges, whereas heavy trucks are used for load testing, it was necessary to carefully determine their number and mass in order to ensure that the adequate internal forces were achieved. According to the Testing Program, which was prepared and subsequently approved by the supervisory authority and the designer, the load testing of the Drivuša bridge was carried out using six heavy trucks. The individual mass of each vehicle was about 400 kN, and the trucks were positioned so as to induce the maximum stresses both in the spans and above the supports (Figures 3 and 4).

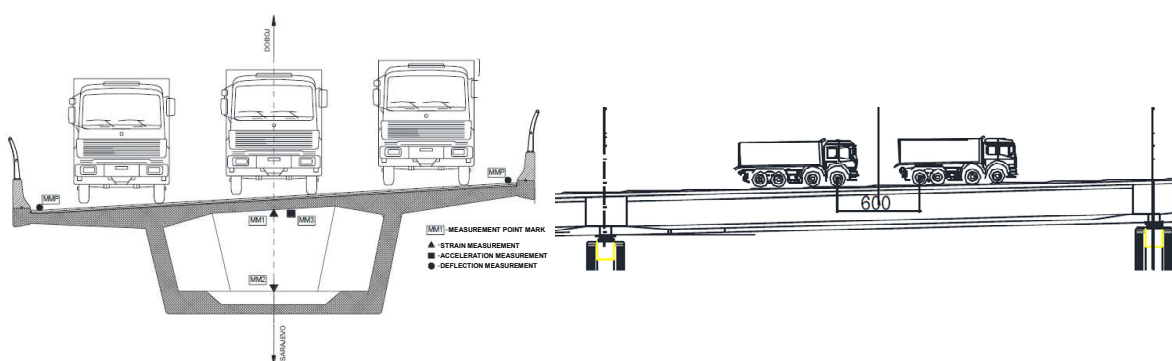

Figure 3. – Position of the trucks in the cross section Figure 4. – Longitudinal position

The success of the conducted testing was determined by calculating the efficiency coefficient. This coefficient is defined as the ratio of the effect of the design load to the effect of the actual test load applied by heavy trucks. According to the regulations used, its value must be within the range of 0.5 to 1.0. The Testing Program of the Drivuša bridge confirmed that the specified condition was met, because the lowest efficiency coefficient was 0.56, recorded during the testing of support S2, while the highest was 0.78, registered during the testing of span 2.

#### 4. MEASUREMENT EQUIPMENT USED

A total of 32 measurement locations were observed on the Drivuša bridge, where strain gauges were installed on the concrete structure inside the bridge (Figure 5).



Figure 5. - Strain gauge at the test location

For measuring relative deformations, strain gauges manufactured by HBM, type K-LY411-15-120-0, were used (Figure 6).



Figure 6. - Strain gauges for concrete

Acceleration was measured using an acceleration transducer, namely an HBM uniaxial accelerometer, type B12/500 (Figure 7a). The measured values were collected by the *MGC plus* system (Figure 7b) and were processed in the Catman AP software package.



a) Acceleration transducer



b) "MGC plus" device

Figure 7. - Measurement equipment used

## 5. RESULTS OF STATIC TESTS AND COMPARISON WITH CALCULATION

Static tests (Figure 8) were carried out according to the loading schemes presented in Chapter 3. The test results for vertical displacements and strains will be presented in the following text.



Figure 8. – Load placed in position

### 5.1 Vertical displacements of the bridge

Vertical displacements were measured using geodetic instruments at two points in the bridge cross section, as shown in Chapter 4, with measurements taken before, during and after the application of the test load. The maximum values for the middle point are shown below. The results obtained from the load test were compared with the results of the computational model developed in the SOFiSTiK software, and the difference is shown. Due to the large number of results, the comparison will be shown only for the left point of the left bridge. The other results also agree very well with the calculated values (Table 1).

The deflection diagram from the computational model, which serves for comparison with the measured deflections, will be shown as an example (Figure 9).

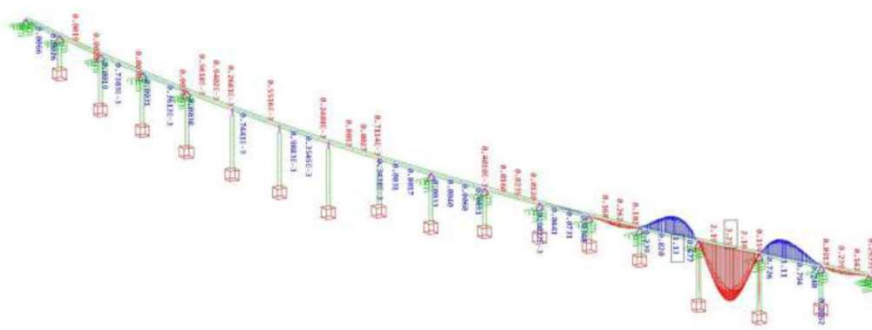

Figure 9. – Example of deflection diagram from computational model

Table 1. – Comparison of measured and calculated deflection results for the left side of the left bridge

POINT	Measurement	Measurement	Measurement		
Measurement	0	1	2		
Date	25.07.'18.	LOADED	UNLOADED		
4	9.6491	9.6463	-2.8	9.6489	- 0.2
P2-5	10.5716	10.5683	-3.3	10.5714	- 0.2
12	11.529	11.5256	-3.4	11.5292	0.2
P4-13	12.6247	12.6215	-3.2	12.6251	0.4
20	13.8438	13.8407	-3.1	13.8441	0.3
P6-21	15.1342	15.1314	-2.8	15.1346	0.4
28	16.5755	16.5725	-3	16.5757	0.2
P8-29	18.0982	18.0954	-2.8	18.098	- 0.2
36	19.7373	19.7347	-2.6	19.7374	0.1
P10-37	21.4818	21.4782	-3.6	21.4822	0.4
44	23.3258	23.3229	-2.9	23.3261	0.3
P12-45	25.1598	25.1575	-2.3	25.1601	0.3
52	26.9165	26.9139	-2.6	26.9169	0.4
P14-53	28.7897	28.7862	-3.5	28.7901	0.4
60	30.787	30.7833	-3.7	30.7867	- 0.3
P16-61	32.7883	32.7852	-3.1	32.7879	- 0.4
68	34.6031	34.6009	-2.2	34.6034	0.3

## 5.2 Relative deformations and stresses of the bridge

The load test results are presented in tables and in diagrams obtained by processing the measured values in the Catman AP software package. Based on the measured strains and known values of the modulus of elasticity for concrete, the stresses are determined according to the formulas:

- Stress for concrete (C40/50):  $\sigma = \varepsilon(\%) \cdot 35000(\text{MPa})$

Due to the large number of results, an example of a diagram for span U1-S1 (left bridge) will be shown (Figure 10), after which a comparison of stresses by measurement points on the left bridge will be presented in a table (Table 2).

Jurišić, M., Kustura, M., Šunjić, G.  
**Load testing of the Drivuša bridge**

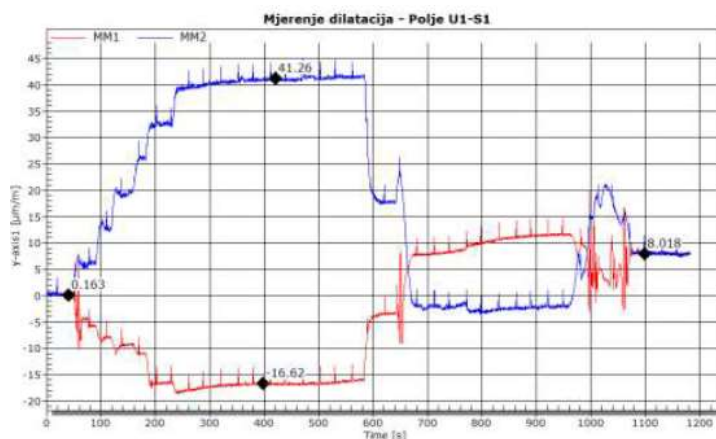

Figure 10. – Example of measured values of relative deformations for span U1-S1 (left bridge)

Table 2. – Comparison of stresses by measurement points on the left bridge

Measurement point	Measured (MPa)		Calculated (MPa)		Difference (MPa)	
	MM1	MM2	MM1	MM2	MM1	MM2
Span U1-S1	-0.58	1.43	-0.68	1.33	0.1	0.1
Support S1	0.39	-0.08	0.45	-0.47	0.06	0.39
Span S1-S2	-0.66	1.06	-0.62	1.33	0.04	0.27
Support S2	0.2	/	0.33	-0.34	0.13	/
Span U2-S16	-0.67	0.85	-0.52	1.03	0.15	0.18
Support S16	0.34	-0.09	0.47	-0.5	0.13	0.41
Span S15-S16	-0.74	1.04	-0.61	1.3	0.13	0.26
Support S15	0.18	/	0.29	-0.32	0.11	/

## 6. RESULTS OF DYNAMIC TESTS AND COMPARISON WITH CALCULATION

In the dynamic testing of the bridge, vertical accelerations induced by excitation with a vehicle traveling at approximately 30 km/h over a 5 cm thick wooden plank in span S15-S16 were measured using an accelerometer (Figure 11). After processing the results, a diagram of the oscillation frequencies of the bridge was obtained (Figure 12).

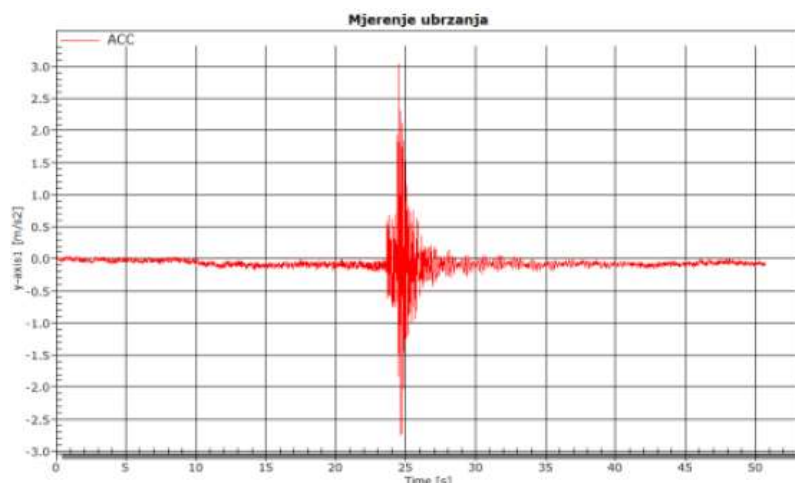

Figure 11. - Acceleration record obtained by the accelerometer

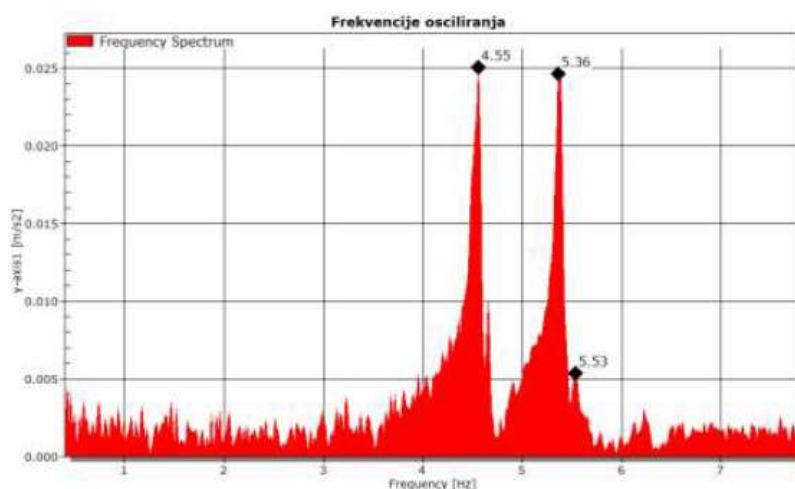

Figure 12. - Oscillation frequencies

Modal shapes of oscillation were determined using the computational model (Figure 13). The results were then processed to determine the bridge oscillation frequencies, which were compared with the calculated values (Table 3).

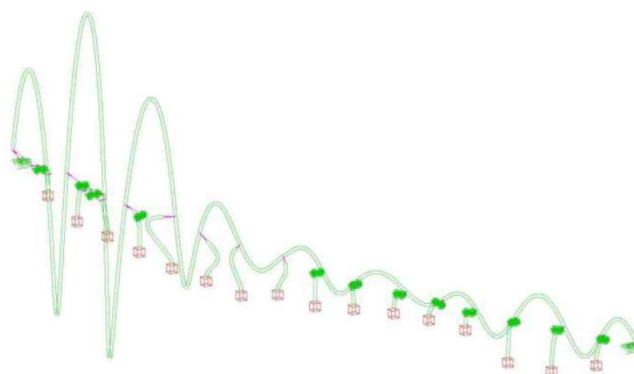

Figure 13. - First calculated modal shape of oscillation (T= 4.01 Hz)

Table 3. - Comparison of oscillation frequencies

Frequency (Hz)	Value 1	Value 2	Value 3
Calculated values	4.01	4.13	4.24
Measured values	4.55	5.36	5.53

## 7. CONCLUSION

For the purpose of a comprehensive analysis of the structural behavior, the Drivuša bridge was load tested in order to verify its compliance with the project, confirm the quality of the performed works and evaluate the ability to bear the designed static and dynamic traffic load. During these tests, key static and dynamic parameters, including displacements, stresses and natural frequencies, were experimentally determined and then compared with the corresponding calculated (theoretical) values. The analysis performed showed a high level of agreement between the experimentally measured and calculated parameters, which unequivocally confirms that the bridge behaves in accordance with the design under service conditions. This successfully verified the performance of the structure, thus fulfilling the prerequisite for putting the Drivuša bridge into service.

## 8. REFERENCES

1. <https://www.jpautoceste.ba/>
2. JUS U.M1.046:1984 Pravilnik za ispitivanje mostova probnim opterećenjem, Sl. list 60/84
3. Rak, M.; Krolo, J.; Bartolac, M.: Ispitivanje i analiza parametara velikih lučnih mostova, Građevinar 62, pp. 913-920, Zagreb, 2010.
4. Biondić, H.: Probno opterećenje mostova, Ekscentar, No. 14, pp. 80-83, Zagreb, 2011.
5. Test Report for the Drivuša bridge on the Corridor Vc motorway, section Drivuša-Klopče, Faculty of Civil Engineering, University of Mostar, Mostar, August 2018 (in Croatian).
6. <https://www.sofistik.com/en/>