

LUMINESCENCE OF PHOSPHORUS COMPOUNDS

Z. Vejnović, M. Davidović
„Boris Kidrič“ Institute of Nuclear Sciences, Vinča, Beograd
and
F. Boreli
Faculty of Electrical Engineering, University of Belgrade, Beograd

Abstract

Thin layers of phosphorus compounds ZnS : Ag, (Zn, Cd) S : Ag and Gd₂O₂S : Tb were examined by method of optical luminescence. The apparatus was assembled in order to measure the x-ray conversion efficiency (light output per incident x-ray energy).

Phosphorus screens were excited with x-rays in the energy range 26 – 40 keV obtained from a Cu target spectrographic tube. The screens were prepared by sedimentation. The phosphorus efficiency was measured as a function of screen weight for different x-ray tube voltages.

1. INTRODUCTION

The luminescence of the ZnS : Ag, (Zn, Cd) S: Ag and Gd₂O₂S : Tb, was investigated. Luminescence, the emission of visible light, is a property associated with interstitial or substitutional impurities. The general pattern for luminescence of inorganic luminescent materials or phosphorus is a crystal lattice containing emission centres, which may be either interstitial or substitutional impurities, excess atoms, ions. The band theory of crystalline solids provides a suitable model for the effect of luminescence of inorganic crystals¹⁾. Variations are due to impurities producing local electronic levels in the forbidden region between the conduction and valence bands. If these levels are unoccupied, electrons and holes, which appear in the x-ray absorption process, moving in the conduction and the valence band in their vicinity may enter these centers. There are three main types of centres: luminescence, quenching and traps. The same centre may contain luminescence, quenching and trapping levels, their relative population being determined by the Boltzmann statistical distribution.

The x-ray conversion efficiency of phosphorus screens can be described as the efficiency with which incident x-ray energy is converted in to useful light energy. This efficiency, G , may be expressed as:

$$G = a \cdot \eta \cdot \gamma \quad (1)$$

where a is the fraction of the incident X-ray energy which is absorbed, η is the efficiency of the phosphorus for the conversion of absorbed X-ray energy (luminescent yield), and γ is the efficiency with which the light energy is transmitted through the phosphorus layer to the detector. The efficiency η depends on the incident X-ray spectrum, composition of the screen and screen weight. The efficiency γ is at least approximately equal to the efficiency of the phosphorus under cathode ray excitation and it depends on activator concentration. The transmission efficiency depends on the light scattering and absorption parameters of the screen, screen weight and the boundary conditions on the surfaces.

2. EXPERIMENT

The experimental arrangement is shown in Fig. 1. It consisted of an X-ray spectrographic Cu tube, optical system, calibrating system, monochromator and detecting system. This apparatus was enabled to measure the spectral brightness of the phosphorus screen excited with X-rays. The photomultiplier sensitivity to the spectrum emitted by phosphorus was calibrated by a standard source of spectral brightness (tungsten-strip lamp). The screen were prepared by sedimentation. The screen's substrate was optical glass.

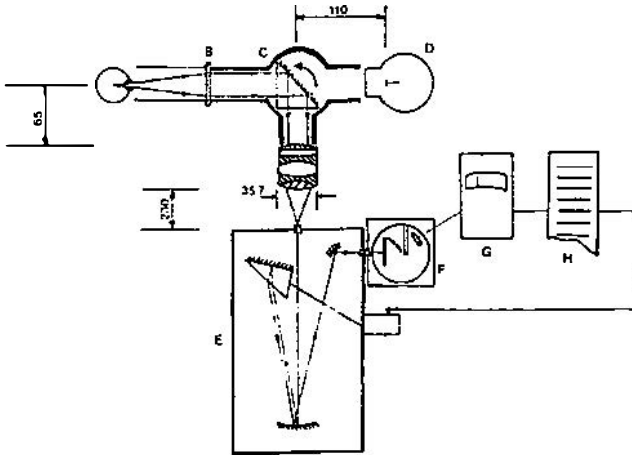

Fig. 1. Experimental arrangement: (A) X-ray tube, (B) phosphorus screen, (C) optical system, (D) tungsten-strip lamp, (E) monochromator, (F) photomultiplier, (G) electrometer, (H) plotter

Low energy radiation from the X-ray tube excites the phosphorus as screen. Emission of visible light with a characteristic spectrum follows the absorption of x radiation, which is of higher energy than the emission. Visible light from the phosphorus screen passes through the optical system, is analyzed by monochromator from short wavelength 390 nm up to 650 nm, and measured with the photomultiplier and electrometer. The results are recorded on the plotter.

3. RESULTS

The variations of the measured X-ray absolute efficiency $G(\%)$ versus tube voltage, for different screen weights W are plotted in Fig. 2.

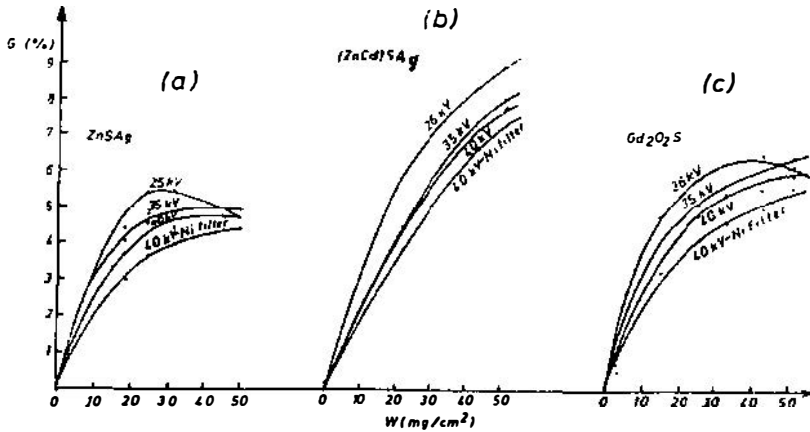

Fig. 2. X-ray conversion efficiency of (a) ZnS : Ag, (b) (Zn, Cd) S : Ag, and (c) Gd₂O₂S : Tb phosphorus screens

4. DISCUSSION AND CONCLUSION

In selecting a powder phosphorus for efficient x-ray detection one must obviously optimize the three factors^{2, 3, 4)}. X-ray absorption is determined only by phosphorus composition and screen weight. The luminescence yield will vary somewhat with preparative techniques, but usually not by more than 20 – 30%. The transmission efficiency γ (Equ. 1) will depend on the grain size of phosphorus and their distribution in the screen.

The result of this paper is that (Zn, Cd) S : Ag screens were superior, for the low x-ray energy region, (Fig. 2.) in x-ray conversion efficiency in relation on the other screens. In the low energy x-ray region there is no advantage in absorption α (Equ. 1) for any phosphor screen. In this energy region (Zn, Cd) S : Ag has a higher luminescence yield η and transmission efficiency γ (Equ. 1).

The author (V. Z.) would like to thank Mr. S. Todorović and Mrs. M. Vajs, from the electronic Industry – Niš, for cooperation concerning the production of the samples.

REFERENCES

1. J. B. Birks, The Theory and Practice of Scintillation Counting, Pergamon Press Ltd., 1967
2. G. W. Ludwig, J. Electrochem. Soc. 118, 1152 (1971)
3. G. W. Ludwig, JEEE Trans. Nucl. Sci. NS-19, No 4, 3 (1972)
4. C. D. Nomicos, G. E. Giakoumakis, P. C. Euthymiou and P. H. Sandilos, J. Appl. Phys., 49 (6), June 1967