

### A c k n o w l e d g m e n t

The work was supported in part by the Federal Fund for Scientific Work. The experiments have been made during the authors stay at the Institute for Electron Physics, Royal Institute of Technology, Stockholm.

### R e f e r e n c e s

- 1) E. Smars and K. Acinger, VIII th ICPIG, Vienna (1967) paper 3. 2. 8. 5;
- 2) M. Kock and J. Richter, *Z. Astrophysik* 69 (1968) 180;
- 3) O. Roder and Z. *Astrophysik* 55 (1962) 38;
- 4) R. Hefferlin and J. Gearhart, *JQSRT* 4 (1964) 3;
- 5) I. Miyachi and K. Jaya Ram, *J. Phys. B* 2 (1969) 425;
- 6) K. H. Krysmanski, *Annalen der Physik* 15 (1965) 162 and 207.

#### 3.16 Time-resolved spectroscopy of a pulsed discharge in a magnetic field

A. PETRAKIEV and R. MILANOVA, *University of Sofia, Department of Physics, Sofia, Bulgaria*

#### 3.17 Spectroscopic observations of D<sub>2</sub>T — tube plasma behind reflected shock front

M. PAVLOV, *Zavod za fiziku i matematiku, Novi Sad, Yugoslavia*

#### 3.18 Optical spectrum of the pulsed gas magnetron discharge

V. I. MILJEVIĆ and D. Đ. TOŠIĆ, *Institute of Nuclear Sciences "Boris Kidrič", Beograd, Yugoslavia*

Low density plasmas are strongly influenced by external fields. This is also the case with the cylindrical magnetron diode at low pressure, in which the axial magnetic field set above a critical value, increases enormously the electron paths and probability for ionization. According to the equivalent pressure conception, the system consisting of crossed electric and magnetic fields can be replaced with a system without the magnetic field, where instead of the existing pressure  $p$  the equivalent pressure is used  $p_{\text{eq}} = p (1 + (\omega_c/\nu_c)^2)^{1/2}$ , where  $\omega_c$  is the cyclotron frequency and  $\nu_c$  collision frequency. For example, at the magnetic field of the order

of 100 Gs and pressure  $10^{-5}$ – $10^{-4}$  torr,  $\omega_c \gg \nu_c$ , we obtain  $p_{eq} \approx p\omega_c/\nu_c$ , which means that the equivalent pressure has also been increased for several orders of magnitude.

In our experiments it was shown that the application of the external magnetic field on the gas diode leads to appearance of an intense gas discharge, although the pressure is low. In the experiments we used the cylindrical magnetron diode, filled with argon ( $p=10^{-5}$ – $10^{-4}$  torr), through which a condenser bank ( $5 \mu\text{F}$ , 800 V) was discharged. The maximum discharge currents were about 50 A. The optical spectrum was registered through the 3 mm anode slit, defined in such a way that a cathode could be seen partially through it. The spectra were registered with a STE-1 spectrograph in two wave length regions: 4<sup>th</sup> order spectra 2375–3500 Å,  $d=4.7$  Å/mm; 3<sup>rd</sup> order spectra 3165–4660 Å,  $d=6.4$  Å/mm.

The experimental arrangement is shown in Fig. 1. Spectra were analysed at the following working conditions:

- (a)  $p = 5 \cdot 10^{-4}$  torr,  $B = 600$  Gs,  $U_a = 800$  V;  
 (b)  $p = 5 \cdot 10^{-5}$  torr,  $B = 600$  Gs,  $U_a = 800$  V.

In the first case, 70 spectral lines in the wave range of 3920–4660 Å were identified. The spectrum contained intense lines of ionized argon (AII) and impurity lines: Oxygen (OII) and tungsten (WI). The oxygen is residual gas, while the tungsten was evaporated from the cathode. The spectrum contains 33 lines of AII and

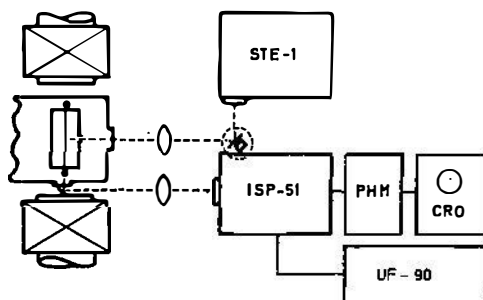

Fig. 1. The experimental arrangement.

15 lines of OII. The atomic lines of argon were not registered, although there is a great number of intense lines in this region. The time appearance of the spectral lines with respect to the anode voltage pulse was about  $10 \mu\text{s}$ . The spectrum registered under the conditions (b) has fewer lines in the same wave length region.

The part of the spectrum of the pulsed discharge with the reference iron spectrum for conditions (a) is presented in Fig. 2. The reproduced shapes and intensities of the spectral lines of that part of the spectrum are given in Fig. 3.

As it can be seen, the optical spectrum of the gas magnetron discharge contains only argon and oxygen ion lines. This points out that excited ions are produced in direct collisions between electrons and atoms in the ground state. Thus the electron energy distribution possesses a group of unequilibrium fast electrons with an energy of about 36 eV.

