

Evaluation of milk and dairy products by electronic tongue

*Mirjana Hruškar**, *Nikola Major*, *Marina Krpan*,
Ines Panjkota Krbavčić, *Goran Šarić*, *Ksenija Marković*, *Nada Vahčić*

Department of Food Quality Control and Nutrition,
Faculty of Food Technology and Biotechnology, University of Zagreb,
Pierottijeva 6, Zagreb

Received - Prispjelo: 01.04.2009.

Accepted - Prihvaćeno: 09.07.2009.

Summary

The concept of electronic tongue or taste sensor has been developed rapidly in the last decade due to their large potential in food quality control. The electronic tongue is based on electrochemical sensors combined with multivariate data analysis. The aim of this study was to evaluate the discriminating ability of the electronic tongue for the recognition of different milk and yoghurt samples from different producers and various dairy products from one producer. The results were evaluated by multivariate data analysis - Principal components analysis. The electronic tongue α -ASTREE (Alpha M.O.S) has successfully distinguished five brands of milk purchased on the Croatian market, five brands of yoghurt also purchased on Croatian market and differentiated among various products from one dairy producer.

Key words: electronic tongue, dairy products, sensor array

Introduction

The electronic tongue uses a sensor array with partially overlapping selectivity to get information on quality parameters such as sample condition, the state of a process, or expected human perception (Winqvist et al., 2004). Sensors forming the array should exhibit various selectivity patterns to minimize correlation between sensor responses, which provides more information about the sample (Ciosek et al., 2006). The logic behind the application of low-selectivity sensors is based on an analogy to biological organization of the olfactory and taste systems in mammals. Millions of nonspecific olfactory receptors are located in the nose and tongue which respond to various substances in gas or liquid form. The signal is transmitted to the brain where olfactory neurons process the signal and the image of the sensed substance is formed (Vlasov et al., 2005). As the electronic tongue classifies particular properties in complex systems, the results are not

necessarily compared to human sensation but with other quality properties in a sample (Winqvist et al., 2004). Various recognition techniques are applied in electronic tongues; potentiometry, voltammetry and conductometry being most commonly used (Winqvist et al., 2004). The data obtained from the electronic tongue is processed by multivariate data analysis (MVDA), primarily by principal components analysis (PCA) which explains the variance in the experimental data. Potentiometric electronic tongues using lipid/polymer membranes have a concept of global selectivity which implies the ability to classify vast kinds of chemical substances into several groups, as really found in the taste reception in biological systems (Toko, 1998). The measuring principle is based on the potential of electrodes across an ion-sensitive membrane with zero current flow (Winqvist et al., 2004). Voltammetric electronic tongues are based on metal electrodes with different selectivity and sensitivity patterns (Söderström et al., 2003). Through these electrodes a

*Corresponding author/Dopisni autor: Phone/Tel.: +385 1 4605 043; E-mail: mhruskar@pbf.hr

varying potential is applied to change the current/voltage characteristics of an electrolytic solution which is then measured. Conductometry is the direct measurement of the conductance between two inert identical electrodes, so that most specific effects due to electrodes are eliminated (Pioggia et al., 2007).

The use of sensor arrays in food analysis grew rapidly in the last decade. It has been used in wine analysis (Buratti et al., 2007; Parra et al., 2006; Buratti et al., 2004; Riul et al., 2004; Di Natale et al., 2004; Legin et al., 2003; Di Natale et al., 2000), honey classification (Dias et al., 2008), soy sauce analysis (Iiyama et al., 2000), water analysis (Moreno et al., 2006; Gallardo et al., 2003; Riul et al., 2003) and other beverages like soft drinks, beer, tea, coffee and milk (Ciosek et al., 2007; Ciosek and Wróblewski, 2007; Ciosek et al., 2006; Ciosek et al., 2004; Lvova et al., 2002; Legin et al., 2000; Vlasov et al., 2000; Legin et al., 1997; Winqvist et al., 1997). Other uses, which do not include food analysis, are microbial species detection (Söderström et al., 2003), heavy metals detection (Gismera et al., 2009; Calvo et al., 2007; Rudnitskaya et al., 2008), rare earth metal ion detection (Legin et al., 2008) and ion detection (Gutierrez et al., 2008; Gutierrez et al., 2007).

Sensor arrays combined with multivariate data analysis are a powerful tool for monitoring quality control in various fields of dairy industry. Both the electronic nose (Brudzewski et al., 2004; Capone et al., 2001) and electronic tongue were used in the assessment of dairy products. Winqvist et al. (1998) started to use the voltammetric electronic tongue to monitor the deterioration of milk quality due to microbial growth. Winqvist et al. (2005) also implemented the voltammetric electronic tongue into the production line to follow different sources of milk coming into the process and to monitor the cleaning process after pasteurization. Dias et al. (2009) developed a potentiometric electronic tongue and used it in the detection of goat milk adulteration with bovine milk. Paixão and Bertotti (2009) developed a disposable voltammetric electronic tongue and it was used to differentiate among milks with different pasteurization processes and adulterated milk with hydrogen peroxide. Bjorklund et al. (2009) used a voltammetric electronic tongue to monitor yoghurt production in a pilot facility.

The aim of this work was to evaluate the discriminating ability of the electronic tongue to differentiate milk and yoghurt samples from different producers and various dairy products from only one producer. The electronic tongue used in this study is based on potentiometry and the sensor array consists of seven sensors coated with lipid/polymer material and an Ag/AgCl reference electrode.

Materials and methods

The potentiometric electronic tongue

The potentiometric electronic tongue used in this study was α -ASTREE, Alpha M.O.S. Co., Toulouse, France. It included the automatic sampling system, the sensor array with the reference electrode, the signal processing unit and a personal computer with the Software Astree 3.0.1. installed. The sensor array consisted of seven sensors coated with lipid/polymer material and a reference Ag/AgCl electrode. The interaction of compounds in the sample and the sensitive coating of sensors generate potential on the membranes which is measured between the sensors and the reference electrode. Potentiometry is the direct application of the Nernst equation through the measurement of the potentials of non-polarized electrodes with no current flowing. The potentials depend on the nature and concentration of the ionic species in solution as well as on the medium and the type of electrodes (Pioggia et al., 2007). Sensors were conditioned with milk samples before the actual measurements were performed.

Samples

The analyzed samples were obtained from the local distributor in triplicate and stored at +4 °C. The six samples of milk were purchased from five producers (Vindija, Meggle, Ljubljanske Mlekarne, KIM, Dukat), five samples of yoghurt (Vindija, Meggle, KIM, Dukat, Đurđevački) and seven different samples of dairy products from one producer (milk, "AB kultura", kefir, "Sensia", sour cream, liquid and firm yoghurt).

Measurement procedure

Three series of products were analyzed (milk brands, yoghurt brands and the range from one

producer). Three measurements were performed each day during three days for each product series. The obtained data was evaluated and each day one measurement was selected according to the lowest available sensor drift value. The selected results were further analyzed by PCA. Each day a fresh package of milk or dairy product was opened prior to analysis. The acquisition time was 200 seconds for each sample, which was experimentally determined to be optimal for flat responses of the sensors. Between each measurement the sensors were cleaned with deionized water. The sensor signals were acquired using the Software Astree 3.0.1. installed on a PC.

Data analysis

The acquired data was evaluated using principal components analysis (PCA) with the embedded Software Astree 3.0.1. This statistical method is favorable because it is a way of identifying patterns in data and it expresses the data in such a way that it highlights their differences and similarities. It reduces the amount of data to a smaller number of new derived variables which represent the original data adequately (Shlens, 2005).

Results and discussion

Application of the potentiometric electronic tongue to differentiate milk samples

The electronic tongue was used to differentiate among six samples of milk regularly found on Croatian market. Figure 1 represents the PCA plot with the first two principal components (C1, C2) for five different milk brands, while Figure 2 represents the PCA plot with the first three principal components (C1, C2, C3) of the same milk brands. In Figure 1 the first principal component (C1) explains 59.157 % of the total variance and the samples are grouped into three distinct groups - Vindija and Ljubljanske Mlekarne belong to one group, two Dukat samples are the second group, KIM and Meggle samples being the third group. The second principal component (C2) in Figure 1 explains 30.386 % of the variance between the samples and two groups of samples are formed. The first group comprises of Ljubljanske Mlekarne sample and two Dukat samples. The second group is formed from Vindija, KIM and Meggle samples. If the third component is introduced (Figure 2), which explains 6.584 % of the total variance, all the samples can be clearly distinguished, except the two samples from Dukat (Dukat milk with 2.8 % milk

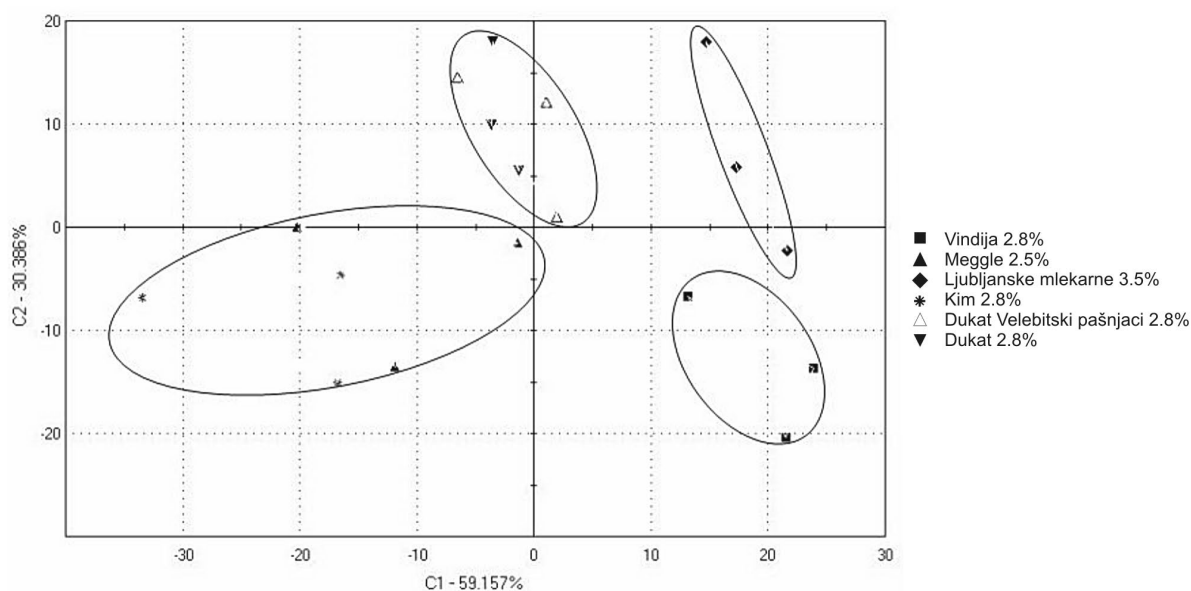

Figure 1: 2D PCA plot of milk samples measurements
Slika 1: 2D PCA prikaz rezultata mjerenja uzoraka mlijeka

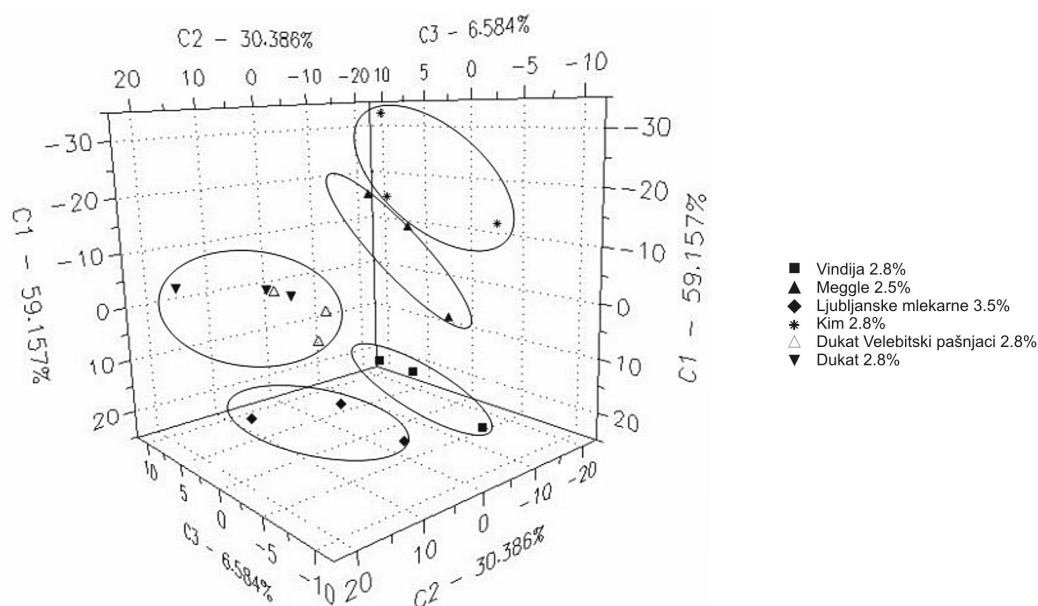

Figure 2: 3D PCA plot of milk samples measurements
Slika 2: 3D PCA prikaz rezultata mjerenja uzoraka mlijeka

fat and Dukat Velebitski pašnjaci milk with 2.8 % milk fat) which have no distinctive differences on the first three principal components (C1, C2, C3). The total variance explained among the samples by the first three principal components (C1, C2, C3) is 96.127 % and the PCA plot shows the difference between all of the five milk producers. Results obtained by Ciosek and Wróblewski (2008; 2006) are similar to the results presented in this paper. The authors were able to differentiate among five brands of milk using an electronic tongue with partially selective electrodes. Also, similar results were obtained by Collier et al. (2003) where an electronic tongue based on differential pulse voltammetry was developed and used to discriminate among cultured and non-cultured dairy products, among milks and a range of yoghurts. In the authors experiment with milk samples four brands of milk were successfully recognized and distinguished.

Application of the potentiometric electronic tongue to differentiate yoghurt samples

The second part of the experiment was performed on yoghurt. Five yoghurt samples from different producers were analyzed by electronic tongue. Figure 3 presents the PCA plot with two principal components (C1, C2) explaining 79.902 % of the total variance between the samples. The first

principal component (C1) explains 57.888 % of the variance and the samples form four distinct groups: Vindija samples group, Đurđevački samples group, Meggle samples group and Kim samples group. Meggle and KIM samples groups can be differentiated from each other but not so clearly as the other two groups. Dukat samples are positioned widely across the middle of the PCA plot entering in the KIM, Meggle and Vindija groups. The second principal component (C2) represents 22.014 % of the total variance and on this component no distinct groups are formed meaning that the differences between the samples of the same producer are greater than the differences between different producers for the given variance. On Figure 4 the third principal component (C3) explains 10.968 % of the variance between the samples. Although there are no distinct groups on the third principal component (C3) (similarly as the second component) it gives a more accurate distinction between all of the samples when paired with the first principal component (C1). The first three principal components (C1, C2, C3) explain 90.870 % of the total variance and the PCA plot shows that the differences between all of the five yoghurt producers are recognized. In conformance to the results in this paper Collier et al. (2003) were able to distinguish between four brands of yoghurt using a self-constructed electronic tongue.

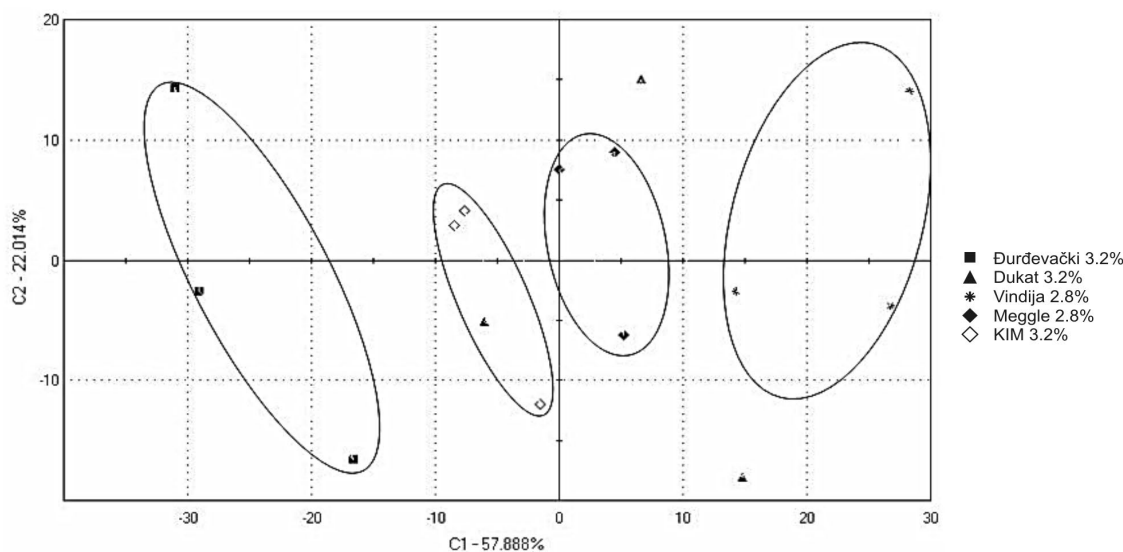

Figure 3: 2D PCA plot of yoghurt samples measurements
Slika 3: 2D PCA prikaz rezultata mjerenja uzoraka jogurta

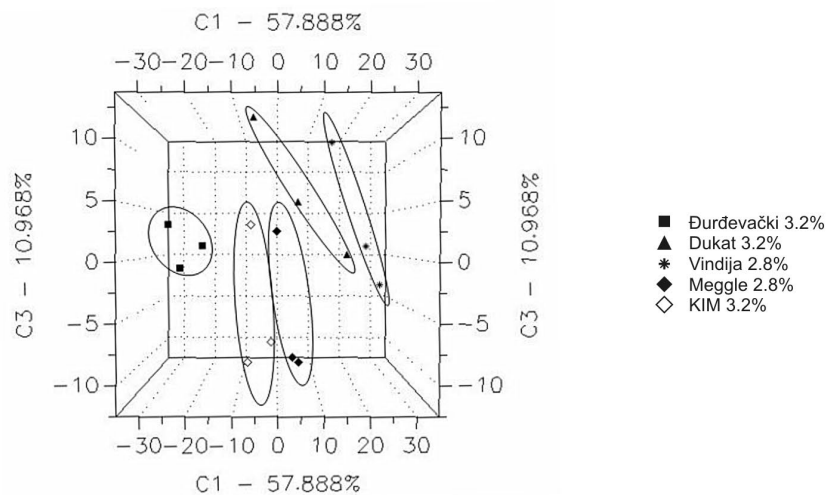

Figure 4: 3D PCA plot of yoghurt samples measurements
Slika 4: 3D PCA prikaz rezultata mjerenja uzoraka jogurta

Application of the potentiometric electronic tongue to differentiate among different dairy products

Figure 5 presents the PCA plot of different dairy products. The total variance of the first two principal components (C1, C2) is 97.104 %. The first principal component (C1) explains 92.516 % and the second principal component (C2) 4.588 % of the total variance. The samples form four groups on the first principal component (C1): milk and “AB

kultura” samples are one group, kefir samples the second, “Sensia”, sour cream and yoghurt samples are the third group and firm yoghurt samples being the fourth group.

On the second principal component (C2) the samples form three groups: milk samples and kefir samples are two opposite groups, while the third group comprises of the “AB kultura”, sour cream, “Sensia”, yoghurt and firm yoghurt samples. When

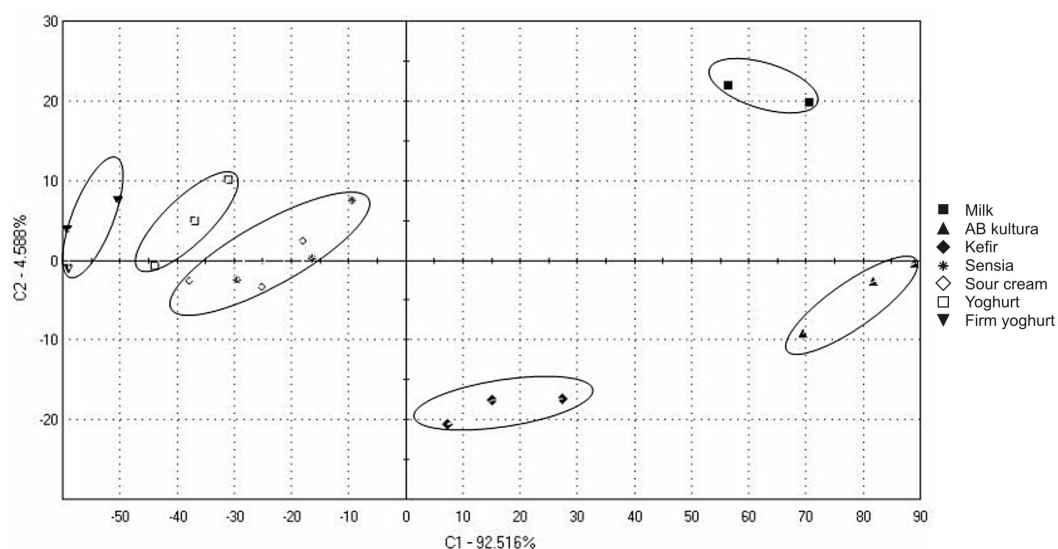

Figure 5: 2D PCA plot of milk and dairy products measurements

Slika 5: 2D PCA prikaz rezultata mjerenja uzoraka mlijeka i mliječnih proizvoda

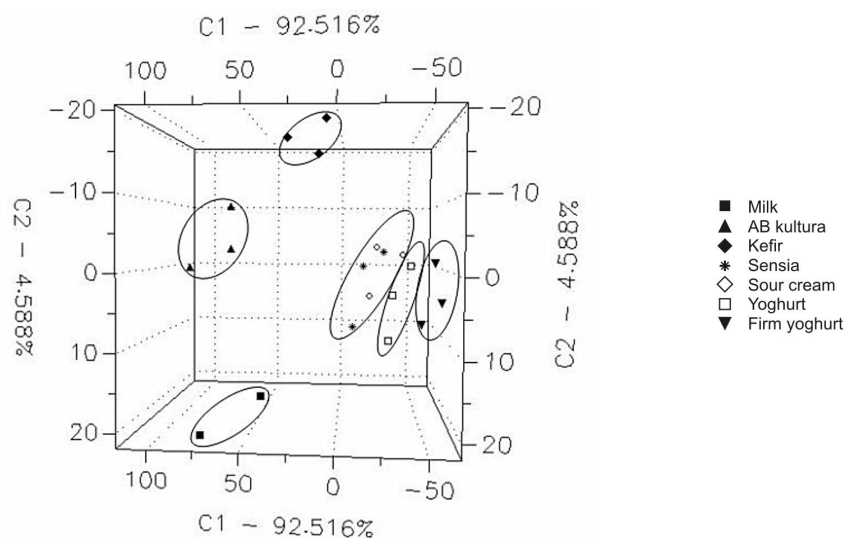

Figure 6: 3D PCA plot of milk and dairy products measurements

Slika 6: 3D PCA prikaz rezultata mjerenja uzoraka mlijeka i mliječnih proizvoda

the first two principal components (C1, C2) are combined on the PCA plot, the samples form six distinctive groups. The first group is the milk samples, the second "AB kultura" samples, the third kefir samples, the fourth group is combined from the sour cream and "Sensia" samples, the fifth group is the yoghurt samples and the sixth group firm yoghurt samples. The third principal component (C3) does not bring any more clarification among the

samples thus is omitted from the PCA plot (Figure 6). Results obtained by Winqvist et al. (2000) can be partially compared to the results in this paper. The authors used an electronic tongue for the classification of six different types of fermented milk. Collier et al. (2003) successfully distinguished cultured and non-cultured dairy products.

Conclusion

The demand for sensor arrays in the food industry is growing because the versatility and ease of operation of those instruments make them appropriate for fast and accurate analysis of various products or for monitoring quality in the production process. This study has shown that a commercial electronic tongue can be used for the evaluation of various products in the dairy industry. The used electronic tongue has successfully distinguished five brands of milk purchased on the Croatian market, five brands of yoghurt also purchased on the Croatian market and differentiated among various products from one dairy producer.

Ocjena mlijeka i mliječnih proizvoda elektronskim jezikom

Sažetak

Elektronski jezik ili senzor okusa prilično je dobro razvijen u posljednjih desetak godina, zahvaljujući njegovu velikom potencijalu u kontroli kvalitete prehrambenih proizvoda. Temeljen je na elektrokemijskim senzorima u kombinaciji s multivarijantnim analizama podataka. Cilj ovog rada bio je pomoću elektronskog jezika raspoznati različite uzorke mlijeka i jogurta različitih proizvođača te različite mliječne proizvode jednog proizvođača. Rezultati su izvedeni iz prikaza dobivenih statističkom metodom analize glavnih komponenata. Pomoću elektronskog jezika α -ASTREE (Alpha M.O.S) uspješno su prikazane razlike između pet uzoraka mlijeka različitih proizvođača kupljenih na hrvatskom tržištu, pet uzoraka jogurta različitih proizvođača kupljenih također na hrvatskom tržištu, te između različitih mliječnih proizvoda jednog proizvođača.

Ključne riječi: elektronski jezik, mliječni proizvodi, matrica senzora

References

1. Bjorklund, R.B., Magnusson, C., Mårtensson, P., Winquist, F., Krantz-Rülcker, C. (2009): Continuous monitoring of yoghurt fermentation using a noble metal electrode array. *International Journal of Food Science & Technology* 44 (3), 635-640.
2. Brudzewski, K., Osowski, S., Markiewicz, T. (2004): Classification of milk by means of an electronic nose and SVM neural network. *Sensors and Actuators B* 98, 291-298.
3. Buratti, S., Benedetti, S., Scampicchio, M., Pangerod E.C. (2004): Characterization and classification of Italian Barbera wines by using an electronic nose and an amperometric electronic tongue. *Analytica Chimica Acta* 525, 133-139.
4. Burrati, S., Ballabio, D., Benedetti, S., Cosio, M.S. (2007): Prediction of Italian red wine sensorial descriptors from electronic nose, electronic tongue and spectrophotometric measurements by means of Genetic Algorithm regression models. *Food Chemistry* 100, 211-218.
5. Calvo, D., Dur'an, A., del Valle, M. (2007): Use of sequential injection analysis to construct an electronic-tongue. Application to multidetermination employing the transient response of a potentiometric sensor array. *Analytica Chimica Acta* 600, 97-104.
6. Capone, S., Epifani, M., Quaranta, F., Siciliano, P., Taurino, A., Vasaneli, L. (2001): Monitoring of rancidity of milk by means of a electronic nose and a dynamic PCA analysis. *Sensors and Actuators B* 78, 174-179.
7. Ciosek, P., Augustyniak, E., Wróblewski, W. (2004): Polymeric membrane ion-selective and cross-sensitive electrode-based electronic tongue for qualitative analysis of beverages. *Analyst* 129, 639-644.
8. Ciosek, P., Brzozka, Z., Wróblewski, W. (2006): Electronic tongue for flow-through analysis of beverages. *Sensors and Actuators B* 118, 454-460.
9. Ciosek, P., Wróblewski, W. (2006): The analysis of sensor array data with various pattern recognition techniques. *Sensors and Actuators B* 114, 85-93.
10. Ciosek, P., Wróblewski, W. (2007): Performance of selective and partially selective sensors in the recognition of beverages. *Talanta* 71, 738-746.
11. Ciosek, P., Mamińska, R., Dybko, A., Wróblewski, W. (2007): Potentiometric electronic tongue based on integrated array of microelectrodes. *Sensors and Actuators B* 127, 8-14.
12. Ciosek, P., Wróblewski, W. (2008): Miniaturized electronic tongue with an integrated reference microelectrode for the recognition of milk samples. *Talanta* 76, 548-556.
13. Collier, W.A., Baird, D.B., Park-Ng, Z.A., More, N., Hart, A.L. (2003): Discrimination among milks and cultured dairy products using screen-printed electrochemical arrays and an electronic nose. *Sensors and Actuators B* 92, 232-239.
14. Di Natale, C., Paolesse, R., Macagnano, A., Mantini, A., D'Amico, A., Ubigli, M., Legin, A., Lvova, L., Rudnitskaya, A., Vlasov, Y. (2000): Application of a combined artificial olfaction and taste system to the quantification of relevant compounds in red wine. *Sensors and Actuators B* 69, 342-347.
15. Di Natale, C., Paolesse, R., Burgio, M., Martinelli, E., Pennazza, G., D'Amico, A. (2004): Application of metalloporphyrins-based gas and liquid sensor arrays to the analysis of red wine. *Analytica Chimica Acta* 513, 49-56.
16. Dias, L.A., Peres, A.M., Vilas-Boas, M., Rocha, M.A., Estevinho, L., Machado, A.A.S.C. (2008): An electronic tongue for honey classification. *Microchimica Acta* 163, 97-102.

17. Dias, L.A., Peres, A.M., Veloso, A.C.A., Reis, F.S., Vilas-Boasa, M., Machado, A.A.S.C. (2009): An electronic tongue taste evaluation: Identification of goat milk adulteration with bovine milk. *Sensors and Actuators B* 136, 209-217.
18. Gallardo, J., Alegret, S., Muñoz, R., de Román, M., Leija, L., del Valle, M. (2003): An electronic tongue using potentiometric all-solid-state PVC-membrane sensors for the simultaneous quantification of ammonium and potassium ion in water. *Analytical and Bioanalytical Chemistry* 377, 248-256.
19. Gismera, M.J., Arias, S., Sevilla, M.T., Procopio, J.R. (2009): Simultaneous Quantification of Heavy Metals Using a Solid State Potentiometric Sensor Array. *Electroanalysis*, doi: 10.1002/elan.200804501 (10.03.2009).
20. Gutiérrez, M., Alegret, S., Cáceres, R., Casadesús, J., Marfà, O., del Valle, M. (2007): Application of a potentiometric electronic tongue to fertigation strategy in greenhouse cultivation. *Computers and Electronics in Agriculture* 57, 12-22.
21. Gutiérrez, M., Moo, V.M., Alegret, S., Leija, L., Hernández, P.R., Muñoz, R., del Valle, M. (2008): Electronic tongue for the determination of alkaline ions using a screen-printed potentiometric sensor array. *Microchimica Acta* 163, 81-88.
22. Iiyama, S., Yahiro, M., Toko, K. (2000): Measurements of soy sauce using taste sensors. *Sensors and Actuators B* 66, 205-206.
23. Legin, A., Rudnitskaya, A., Vlasov, Y., Di Natale, C., Davide, F., D'Amico, A. (1997): Tasting of beverages using an electronic tongue. *Sensors and Actuators B* 44, 291-296.
24. Legin, A., Rudnitskaya, A., Vlasov, Y., Di Natale, C., Mazzone, E., D'Amico, A. (2000): Application of electronic tongue for qualitative and quantitative analysis of complex liquid media. *Sensors and Actuators B* 65, 232-234.
25. Legin, A., Rudnitskaya, A., Lvova, L., Vlasov, Y., Di Natale, C., D'Amico, A. (2003): Evaluation of Italian wine by the electronic tongue: recognition, quantitative analysis and correlation with human sensory perception. *Analytica Chimica Acta* 484, 33-44.
26. Legin, A., Kirsanov, D., Rudnitskaya, A., Babain, V. (2008): Cross-sensitive rare earth metal ion sensors based on extraction systems. *Sensors and Actuators B* 131, 29-36.
27. Lvova, L., Kim, S.S., Legin, A., Vlasov, Y., Yang, J.S., Cha, G.S., Nam, H. (2002): All-solid-state electronic tongue and its application for beverage analysis. *Analytica Chimica Acta* 468, 303-314.
28. Moreno, L., Merlos, A., Abramova, N., Jiménez, C., Bratov, A. (2006): Multi-sensor array used as an "electronic tongue" for mineral water analysis. *Sensors and Actuators B* 116, 130-134.
29. Paixão, T.R.L.C., Bertotti, M. (2009): Fabrication of disposable voltammetric electronic tongues by using Prussian Blue films electrodeposited onto CD-R gold surfaces and recognition of milk adulteration. *Sensors and Actuators B* 137, 266-273.
30. Parra, V., Arrieta, A.A., Fernández-Escudero, J.B., Rodríguez-Méndez, M.L., De Saja, J.A. (2006): Electronic tongue based on chemically modified electrodes and voltammetry for the detection of adulterations in wines. *Sensors and Actuators B* 118, 448-453.
31. Pioggia, G., Di Francesco, F., Marchetti, A., Ferro M., Ahluwalia, A. (2007): A composite sensor array impedentiometric electronic tongue Part I. Characterization. *Biosensors and Bioelectronics* 22, 2618-2623.
32. Riul, A., Gallardo Soto, A.M., Mello, S.V., Bone, S., Taylor, D.M., Mattoso, L.H.C. (2003): An electronic tongue using polypyrrole and polyaniline. *Synthetic Metals* 132, 109-116.
33. Riul, A., de Sousa, H.C., Malmegrim, R.R., dos Santos, D.S., Carvalho, A.C.P.L.F., Fonseca, F.J., Oliveira, O.N., Mattoso, L.H.C. (2004): Wine classification by taste sensors made from ultra-thin films and using neural networks. *Sensors and Actuators B* 98, 77-82.
34. Rudnitskaya, A., Legin, A., Seleznev, B., Kirsanov, D., Vlasov, Y. (2008): Detection of ultra-low activities of heavy metal ions by an array of potentiometric chemical sensors. *Microchimica Acta* 163, 71-80.
35. Shlens, J. (2005) A tutorial on Principal Component Analysis. (<http://www.brainmapping.org/NITP/PNA/Readings/pca.pdf>) (10.03.2009).
36. Söderström, C., Winquist, F., Krantz-Rülcker, C. (2003): Recognition of six microbial species with an electronic tongue. *Sensors and Actuators B* 89, 248-255.
37. Toko, K. (1998): Electronic tongue. *Biosensors and Bioelectronics* 13, 701-709.
38. Vlasov, Y.G., Legin, A.V., Rudnitskaya, A.M., D'Amico, A., Di Natale, C. (2000): "Electronic tongue" - new analytical tool for liquid analysis on the basis of non-specific sensors and methods of pattern recognition. *Sensors and Actuators B* 65, 235-236.
39. Vlasov, Y.G., Legin, A.V., Rudnitskaya, A.M., Di Natale, C., D'Amico, A. (2005): Nonspecific sensor arrays ("electronic tongue") for chemical analysis of liquids (IUPAC Technical Report). *Pure and Applied Chemistry* 77 (11), 1965-1983.
40. Winquist, F., Wide, P., Lundström, I. (1997): An electronic tongue based on voltammetry. *Analytica Chimica Acta* 357, 21-31.
41. Winquist, F., Krantz-Rülcker, C., Wide, P., Lundström, I. (1998): Monitoring of freshness of milk by an electronic tongue on the basis of voltammetry. *Measurement Science and Technology* 9, 1937-1946.
42. Winquist, F., Holmin, S., Krantz-Rülcker, C., Wide, P., Lundström, I. (2000): A hybrid electronic tongue. *Analytica Chimica Acta* 406, 147-157.
43. Winquist, F., Krantz-Rülcker, C., Lundström, I. (2004): Electronic tongues. *MRS Bulletin* 29, 1-6.
44. Winquist, F., Bjorklund, R., Krantz-Rülcker, C., Lundström, I., Östergren, K., Skoglund, T. (2005): An electronic tongue in the dairy industry. *Sensors and Actuators B* 111-112, 299-304.