

Analysis of Internal Deletions of a Rat Col1a1 Promoter Fragment in Transfected ROS17/2.8 Cells

Ante Ivkošić¹, Mark S. Kronenberg², Alexander C. Lichtler² and Barbara E. Kream^{2,3}

¹ Department of Surgery, General Hospital »Sveti Duh«, Zagreb, Croatia

² Department of Genetics and Developmental Biology, University of Connecticut Health Center, Farmington, USA

³ Department of Medicine, University of Connecticut Health Center, Farmington, USA

ABSTRACT

The aim of this paper is identification of regulatory sequences downstream of –1683 base pairs (bp) in the rat Col1a1 promoter important for expression in osteoblasts. Previous findings suggest that a rat Col1a1 gene fragment extending from –1719 to +115 bp linked to the chloramphenicol acetyl transferase (CAT) reporter gene (ColCAT1719) is highly and selectively expressed in osteoblasts. Three internal deletions within the ColCAT1719 construct were generated and stably transfected into ROS 17/2.8 cells. CAT activity was measured in cell extracts. An internal deletion of ColCAT1719 from –1637 to –504 bp caused an almost complete loss of CAT activity, whereas deletions of –1284 to –905 bp and –1284 to –451 bp had little effect on CAT activity. We hypothesized that removal of a Runx2/Cbfa1 consensus site at –1376 bp may have caused the loss of activity produced by the –1637 to –504 bp deletion. To test this hypothesis, we produced a more restricted internal deletion of ColCAT1719 from –1418 to –1284 bp, which removes this site. This deletion did not affect promoter activity. Our results suggest that the Runx2 site at –1376 bp by itself does not influence Col1719 promoter activity. Future studies will focus on the region between –1637 to 1418 bp, which contains several potentially interesting transcription factor binding sites.

Key words: Col1a1 promoter, osteoblast, Runx2, transfection

Introduction

The protein content of bone is composed of approximately 95% type I collagen, with the remainder contributed by a variety of noncollagen proteins and proteoglycans. Type I collagen serves as the essential structural protein of the skeleton, imparting stability and strength to bone tissue. Each type I collagen molecule is a triple helix containing two identical $\alpha 1^1$ chains and one $\alpha 2^1$ chain, which are encoded by two distinct genes¹. A high level of expression of type I collagen is a phenotypic hallmark of differentiated osteoblasts. Type I collagen synthesis in osteoblasts is regulated by a variety of hormones and transcription factors. Hormones such as glucocorticoids², 1,25-dihydroxyvitamin D₃³, parathyroid hormone^{4–5} and fibroblast growth factor^{6–7} inhibit type I collagen synthesis in vitro, whereas insulin like growth factor-I⁸ and transforming growth factor- β ⁹ increase type I collagen synthesis.

Our laboratories have previously developed transgenic mice that harboring Col1a1 promoters linked to the chloramphenicol acetyl transferase (CAT) reporter. The

parental Col1a1-CAT construct containing a 3.6 kb region of the Col1a1 gene from –3591 to +115 bp was termed ColCAT3.6¹⁰. Serial 5' deletions of ColCAT3.6 were generated to map elements that mediate tissue specific expression. CAT activity in calvariae remained high in constructs deleted to –2295, –1997, –1794, –1719, and –1683 bp^{11–13}, while further deletion to –1670 bp completely eliminated activity. These data strongly indicated that transcriptional regulatory elements directing expression in osteoblasts were located between –1683 and –1670 bp¹⁴. Site directed mutation of a TAAT motif within this region showed that it was necessary for high CAT activity in calvariae¹⁴.

The goal of the present study was to identify elements downstream of –1670 bp, which may govern the expression of the rat Col1a1 promoter in osteoblasts. Internal deletions of ColCAT1719 were generated and stably transfected into ROS 17/2.8 cells. A deletion of sequences between –1637 and –1284 bp significantly reduced promoter activity. Interestingly, within that region is a

Runx2 site at –1376 bp. To define its involvement in promoter activity, a more restricted internal deletion encompassing this site was produced. This deletion, however, did not affect promoter activity suggesting that the site is not necessary for expression in osteoblasts.

Materials and Methods

Materials

The sources for material used in this study were as follows: F-12 nutrient mixture, Lipofectamine reagent, oligonucleotides (Invitrogen, Carlsbad, CA, USA); Pflf 1, Stu 1, Aat 2, Bsu 36 1, Bln 1 (New England Biolabs Inc., Beverly, MA USA); Hind 3, Xba 1, Pst 1 enzymes (Invitrogen, Carlsbad, CA, USA); [³H]acetyl coenzyme A, 200 mCi/mmol (NEN Life Science Products Inc, Boston, MA, USA); tissue culture plates (Costar, Cambridge, MA, USA); reporter lysis buffer (Promega, Madison, WI, USA); Econofluor-2 (PerkinElmer Life and Analytical Sciences, Boston, MA, USA).

DNA constructs

The generation of ColCAT1719, which has sequences of the rat Col1a1 promoter between –1719 and +116 bp fused to the CAT reporter gene and the SV40 small T antigen splice site and polyadenylation signal from pSVCAT, has been previously described¹³. Four different internal deletions of ColCAT1719 were generated (Figure 1). To produce Δ 379, ColCAT 1719 was digested with Pflf 1 (–1284 bp), blunt-ended, digested with Stu 1 (–905 bp) and ligated. The second deletion, Δ 833, was produced using a similar approach as for Δ 379 except that Stu 1 was replaced by Bsu 36 1 (–451 bp). The third deletion, Δ 1133, was produced using Bpu 1, which has two restriction sites (–1637 bp, –504 bp) within ColCAT1719. For the fourth deletion, Δ 134, a Hind 3/Xba 1 digested fragment of ColCAT1719 containing 1830 bp, was subcloned in Litmus 28. Subsequently, the DNA was digested with Aat 2 (–1418 bp) and Pflf1 (–1284 bp), blunt-ended, ligated, and digested with Hind 3/Xba 1 to reinsert this truncated promoter into Hind 3/Xba 1 digested ColCAT1719.

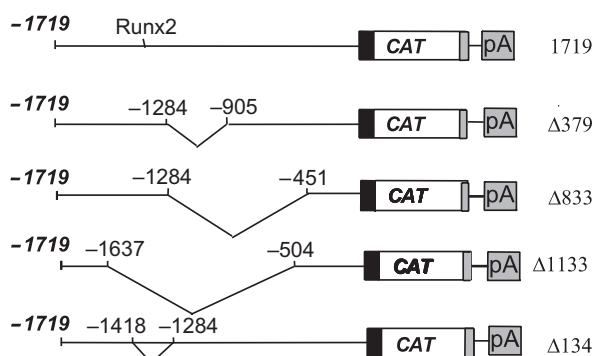

Fig. 1. Internal deletions of ColCAT1719. Constructs were named by the number of deleted base pairs: Δ 379, Δ 833, Δ 1133 and Δ 134. The Runx2 binding at –1376 bp is shown.

Stable transfection

ROS 17/2.8 cells were maintained in F-12 medium supplemented with 10% of non heat-inactivated fetal bovine serum (New England Biolabs inc, Beverly, MA, USA), 100 U/ml penicillin and 50 g/ml streptomycin (basal medium) at 37 °C in a humidified atmosphere of 5% CO₂. On the day prior to transfection, 2×10^5 cells were plated in each 35 mm dish; 18 h later, the cells were rinsed twice with phosphate buffered saline (PBS) and incubated for 5 h in serum- and antibiotic-free F-12 medium containing 1 μ g of a Col1a1-CAT plasmid, 0.1 μ g of TK-Hygro plasmid, which carries the resistance gene for hygromycin, and 8 μ l of Lipofectamine reagent. After 5 h, medium was replaced and the cells were cultured in basal medium for 72 h. The cells were then passaged and placed under selection with 200 μ g /ml of hygromycin. Resistant clones were pooled, grown to confluence, and harvested for measurement of CAT activity.

Measurement of CAT Activity

Cells were scraped into 1 ml of CAT scraping buffer (0.04 M Tris-HCL, pH 7.4, 1 mM EDTA, 0.15 M NaCl), rinsed twice with PBS, pH 7.4, re-suspended and centrifuged for 5 min. Pellets were re-suspended in buffer containing 0.25 M Tris-HCl (pH 7.8) and 0.5 % Triton X-100 and subjected to three cycles of freezing on dry ice, each followed by thawing at 37 °C. The extracts were heated at 65 °C for 15–20 min to inactivate endogenous deacetylases and centrifuged at $14,000 \times g$ for 3 min. A fluor diffusion assay was used to measure CAT activity in the extracts as previously described^{5,14}. Up to 10 μ l of extract were added to 200 μ l of a reaction mixture containing 1 mM chloramphenicol, 0.2 μ Ci [³H]acetyl coenzyme A and 0.025 M Tris-HCl, pH 7.8, in a 7 ml scintillation vial. The aqueous phase reaction mix was overlaid with 5 ml toluene or Econofluor-2 based scintillation fluid. The vials were incubated at 37 °C for up to 5 h and counted every hour. CAT activity was calculated as described previously⁵ and was normalized to protein in the extract, as measured with the indicator bicinchoninic acid¹⁵.

Statistics

Data were analyzed using the One-Sample Kolmogorov-Smirnov Test and t-test for Equality of Means.

Results

We stably transfected ROS17/2.8 cells with four constructs having different internal deletions of ColCAT-1719 (Figure 1). Transfected cells were analysed at 2 to 3 days post confluence. Deletion of the sequences between –1284 to –905 bp (Δ 379), and –1284 to –451 bp (Δ 833), did not significantly affect CAT activity. However, a deletion from –1637 to –504 bp (Δ 1133) reduced CAT activity to nearly undetectable levels (Figure 2). These data suggested that a 350 bp region between –1637 to –1284 bp was required for ColCAT1719 expression. A computer search of this sequence revealed a consensus binding site

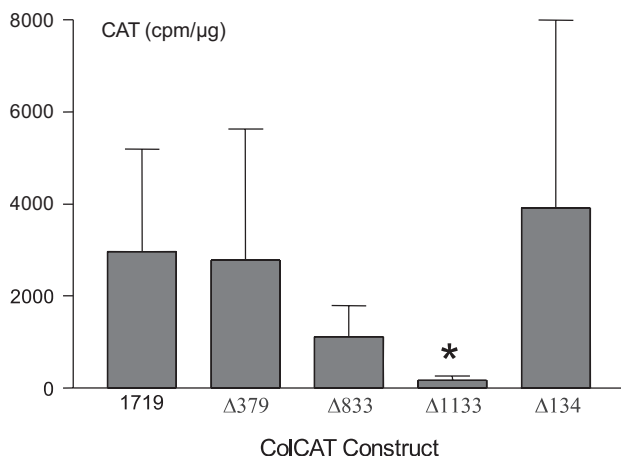

Fig. 2. Effect of internal deletions on CAT activity in stably transfected ROS17/2.8 cells. Each value is the $X \pm SD$ of 6–12 samples. *Different from ColCAT1719, $p < 0.01$. Cpm/ μ g – counts per minute per microgram.

at –1376 bp for the transcription factor Runx2 (Figure 1). To address the possible role of Runx2 in ColCAT1719 expression, we generated a more restricted internal deletion of 134 bp between –1418 and –1284 bp ($\Delta 134$), which included this Runx2 site. There was no significant effect of this deletion on promoter activity (Figure 2). In addition, a specific mutation of the Runx2 also did not inhibit activity (data not shown). Taken together, these data suggest that the region between –1637 and –1418 bp is likely to contain one or more positive transcriptional elements.

Discussion

In the current study, we generated four internal deletions of ColCAT1719 and tested the activity of these constructs in stably transfected ROS17/2.8 osteoblastic osteosarcoma cells^{16–17}. These cells express bone markers such as type I collagen, osteocalcin, alkaline phosphatase, osteopontin, bone sialoprotein, have receptors for parathyroid hormone and 1.25-dihydroxyvitamin D₃, and produce mineralized tumors. Therefore, we have used them previously¹⁰ and in the present study as a model for examining Col1a1 promoter activity in cells of the osteoblast lineage.

Our deletion studies of the Col1a1 promoter identified a region between –1637 and –1284 bp that is necessary for the maximal promoter activity of ColCAT1719, leading us to speculate that this 350 bp region contained important regulatory elements required for promoter activity. A preliminary search of the 350 bp implicated by these internal deletion experiments revealed a Runx2 binding site at –1376 bp.

Runx2 plays a critical role in osteoblastic differentiation and bone formation^{18–20}. Knockout of the Runx2

gene in mice results in a complete loss of osteoblast differentiation. Mutations in the Runx2 gene cause skeletal abnormalities and defective bone formation in cleidocranial dysplasia (CCD), an autosomal dominant disorder in humans and mice^{20–22}. Overexpression of Runx2 regulates osteoblast specific gene expression *in vitro*²⁴ and is able to induce osteoblastic markers in non-osteoblastic cells²⁵. Two isoforms of the Runx2 gene have been identified that differ in their N-terminal sequence²⁶. Runx2 mRNA is expressed in primary bone cells and numerous osteoblastic cell line²⁷. The precise role of Runx2 on Col1a1 expression is not completely understood. Studies have shown both stimulatory^{24–28} and inhibitory³⁰ effects of Runx2 on Col1a1 expression. Therefore, we hypothesized that deletion of a Runx2 site could have contributed to loss of activity seen with the $\Delta 1133$ deletion. The $\Delta 134$ deletion between –1418 and –1284 bp included the Runx2 binding site (Figure 1) at –1376 bp. We predicted that the deletion would abolish promoter activity. However, the deletion did not affect CAT activity in stably transfected ROS17/2.8 cells. In addition, a specific site directed mutation of this Runx2 binding site did not inhibit activity of the construct. These results are in contrast to the studies of Kern et al²⁸, who found that a mutation in the homologous site in the mouse Col1a1 promoter caused an approximately 2-fold decrease in promoter activity. We do not have a conclusive explanation for this discrepancy; however, one possibility is that the mouse Col1a1 promoter may have a different requirement for this promoter element than the rat promoter.

Our studies do not eliminate the possibility that Runx2 binding sites play an important role in regulation of ColCAT1719, because a computer search of the region downstream of –1376 bp revealed four additional Runx2 sites. Future studies involving mutation of these sites, both singly and in combination, will reveal the role of Runx2 in regulating Col1a1 promoter expression.

Previously, it has been shown that a 117 bp sequence of the mouse Col1a1 promoter between –1656 and –1540 bp is the minimal sequence able to induce high levels of expression in osteoblasts^{29–30}. This sequence was further divided into several sub-segments having different functions; a region between –1656 and –1628 bp is required for specific expression in osteoblasts, while a sequence from –1575 to –1540 bp is required for high expression in osteoblasts. Alignment of the mouse and rat sequence within this region reveals a 55 bp overlap between the sequence identified by Rossert et al³⁰ and the sequence identified by our deletion studies, which extends from –1637 to –1582 bp in the rat sequence. Examination of this sequence using the TESS – transcription factor site search web site³¹ revealed several potential transcription factor binding sites with high probability of relevance. Analysis of the significance of these sites by mutation should prove informative in identifying regulatory elements in the Col1a1 promoter.

REFERENCES

1. VAN DER REST, M., R. GARRONE, FASEB J., 5 (1991) 2814. — 2. DIETRICH, J. W., E. M. CANALIS, D. M. MAINA, L. G. RAISZ, Endocrinol., 104 (1979) 715. — 3. HARRISON, J. R., D. N. PETERSEN, A. C. LICHTLER, A. T. MADOR, D. W. ROWE, B. E. KREAM, Endocrinol., 125 (1989) 327. — 4. KREAM, B. E., D. W. ROWE, S. C. GWOREK, L. G. RAISZ, Proc. Natl. Acad. Sci. USA., 77 (1980) 5654. — 5. KREAM, B. E., D. LAFRANCIS, D. N. PETERSEN, C. WOODY, S. CLARK, D. W. ROWE, A. C. LICHTLER, Mol. Endocrinol., 7 (1993) 399. — 6. HURLEY, M. M., M. KESSLER, G. GRONOWICZ, L. G. RAISZ, Endocrinol., 130 (1992) 2675. — 7. HURLEY, M. J., C. ABREU, J. R. HARRISON, A. C. LICHTLER, L. G. RAISZ, B. E. KREAM, J. Biol. Chem., 268 (1993) 5588. — 8. THIEBAUD, D., H. L. GUENTHER, A. PORRET, P. BURCKHARDT, H. FLEISCH, W. HOFSTETTER, J. Bone. Miner. Res., 9 (1994) 1347. — 9. CENTRELLA, M., S. CASINGHINO, R. IGNOTZ, T. L. MCCARTHY, Endocrinol., 131 (1992) 2863. — 10. LICHTLER, A. C., M. L. STOVER, J. ANGILLY, B. E. KREAM, D. W. ROWE, J. Biol. Chem., 264 (1989) 3072. — 11. PAVLIN, D., A. C. LICHTLER, A. BEDALOV, B. E. KREAM, J. R. HARRISON, H. F. THOMAS, G. A. GRONOWICZ, S. H. CLARK, C. O. WOODY, D. W. ROWE, J. Cell. Biol., 116 (1992) 227. — 12. BOGDANOVIC, Z., A. BEDALOV, P. H. KREBSBACH, C. O. WOODY, S. H. CLARK, H. F. THOMAS, D. W. ROWE, B. E. KREAM, A. C. LICHTLER, J. Bone. Miner. Res., 9 (1994) 285. — 13. BEDALOV, A., R. SALVATORI, M. DODIG, M. S. KRONENBERG, B. KAPURAL, Z. BOGDANOVIC, B. E. KREAM, C. O. WOODY, S. H. CLARK, K. MACK, D. W. ROWE, A. C. LICHTLER, J. Bone. Miner. Res., 10 (1995) 1443. — 14. DODIG, M., M. S. KRONENBERG, A. BEDALOV, B. E. KREAM, G. GRONOWICZ, S. CLARK, K. MACK, Y. LIU, R. MAXON, Z. Z. PAN, W. B. UPHOLT, D. W. ROWE, A. C. LICHTLER, J. Biol. Chem., 271 (1996) 16422. — 15. SMITH, P. K., R. I. KROHN, G. T. HERMANSON, A. K. MAILIA, F. H. GARTNER, M. D. PROVENZANO, E. K. FUJIMOTO, N. M. GOEKE, B. J. OLSON, D. C. KLENK, Anal. Biochem., 150 (1985) 76. — 16. MAJESKA, R. J., S. B. RODAN, G. A. RODAN, Exp. Cell. Res., 111 (1978) 465. — 17. MAJESKA, R. J., S. B. RODAN, G. A. RODAN, Endocrinol., 107 (1980) 1494. — 18. OTTO, F., A. P. THORNELL, T. CROMPTON, A. DENZEL, K. C. GILMOUR, I. R. ROSEWELL, G. W. STAMP, R. S. BEDDINGTON, S. MUNDLOS, B. R. OLSEN, P. B. SELBY, M. J. OWEN, Cell., 89 (1997) 765. — 19. MUNDLOS, S., F. OTTO, C. MUNDLOS, J. B. MULLIKEN, A. S. AYLSWORTH, S. ALBRIGHT, D. LINDHOUT, W. G. COLE, W. HENN, J. H. KNOLL, M. J. OWEN, R. MERTELSMANN, B. U. ZABEL, B. R. OLSEN, Cell., 89 (1997) 773. — 20. SCHROEDER, T. M., E. D. JENSEN, J. J. WESTENDORF, Birth. Defects. Res. C. Embryo. Today., 75 (2005) 213. — 21. CUNNINGHAM, M. L., M. L. SETO, A. V. HING, M. J. BULL, R. J. HOPKIN, K. A. LEPPIG, Birth. Defects. Res. A. Clin. Mol. Teratol., 76 (2006) 78. — 22. KIM, H. J., S. H. NAM, H. J. KIM, H. S. PARK, H. M. RYOO, S. Y. KIM, T. J. CHO, S. G. KIM, S. C. BAE, I. S. KIM, J. L. STEIN, A. J. VAN WIJNEN, G. S. STEIN, J. B. LIAN, J. Y. CHOI, J. Cell. Physiol., 207 (2006) 114. — 23. MUNDLOS, S., J. Med. Genet., 36 (1999) 177. — 24. DUCY, P., R. ZHANG, V. GEOFFROY, A. L. RIDALL, G. KARSENTY, Cell., 89 (1997) 747. — 25. XIAO, Z. S., T. K. HINSON, L. D. QUARLES, J. Cell. Biochem., 74 (1999) 596. — 26. XIAO, Z. S., R. THOMAS, T. K. HINSON, L. D. QUARLES, Gene, 214 (1998) 187. — 27. TSUJI, K., Y. ITO, M. NODA, Bone, 22 (1998) 87. — 28. KERN, B., J. SHEN, M. STARBUCK, G. KARSENTY, J. Biol. Chem., 276 (2001) 7101. — 29. ROSSERT, J., H. EBERSPAECHER, B. DE CROMBRUGGHE, J. Cell. Biol., 129 (1995) 1421. — 30. ROSSERT, J. A., S. S. CHEN, H. EBERSPAECHER, C. N. SMITH, B. DE CROMBRUGGHE, Proc. Natl. Acad. Sci. USA., 93 (1996) 1027. — 31. SCHUG, J., G. C. OVERTON, Transcription element search software on the WWW. Technical Report CBIL-TR-1997-1001-v0.0, Computational Biology and Informatics Laboratory, School of Medicine, University of Pennsylvania 1997. Available from URL: <http://www.cbil.upenn.edu/tess>.

A. Ivkošić

Selska 7, 10000 Zagreb, Croatia
e-mail: ante.ivkovic@hi.t-com.hr

ANALIZA UNUTRAŠNJIH DELECIJA DIJELOVA ŠTAKORSKOG KOLAGENSKOG PROMOTORA U TRANSFEKTIRANIM ROS17/2.8 STANICAMA

SAŽETAK

Cilj ovog rada je identifikacija regulatornih sekvenci nizvodno od –1683 parova baza u štakorskom kolagenskom promotoru važnih za ekspresiju u osteoblastima. Prethodna istraživanja su pokazala da je genski fragment štakorskog kolagenskog promotora koji se nalazi između –1719 i +115 parova baza (pb) povezan sa CAT (kloramfenikol acetil transferaza) reporter genom, dakle ColCAT1719, specifično i selektivno izražen u osteoblastima. Tri unutrašnje delecije ColCAT1719 konstrukta su napravljene i stabilno transfektirane u ROS17/2.8 stanice. U ekstraktima stanica mjerena je CAT aktivnost: Unutrašnja delecija ColCAT1719 konstrukta od –1637 do –504 pb uzrokovala je gotovo potpuni gubitak CAT aktivnosti, dok su delecije od –1284 do –905 i od –1284 do –451 pb imale mali efekt na CAT aktivnost. Pretpostavili smo da je odstranjenje Runx2-Cbfa1 konsenzus mjesta na –1376 pb uzrokovalo gubitak aktivnosti proizveden sa delecijom od –1637 do –504 pb. Za testiranje ove pretpostavke napravili smo još specifičniju unutrašnju deleciju ColCAT1719 konstrukta od –1418 do –1284 pb, kojom se odstranjuje ovo mjesto. Ova delecija nije imala učinka na promotorsku aktivnost. Naši rezultati pokazuju da Runx2 mjesto na –1376 pb samo po sebi nema utjecaja na aktivnost Col1719 promotora. Buduća istraživanja će se usredotočiti na područje između –1637 i 1418 pb, koje sadrži nekoliko potencijalno zanimljivih veznih mjesta za transkripcijske faktore.