

ULOGA UMJETNE NEURONSKE MREŽE U DETEKCIJI ABNORMALNOSTI U FUNKCIJI RADA PLUĆA THE ROLE OF ARTIFICIAL NEURAL NETWORKS IN DETECTION OF PULMONARY FUNCTIONAL ABNORMALITIES

Aneta MIRCESKA – Andrea KULAKOV – Saso STOLESKI

Sažetak: Umjetna neuronska mreža je sustav temeljen na radu biološke neuronske mreže, drugim riječima, ona predstavlja oponašanje biološke neuronske mreže. Cilj ovog rada je usporediti svojstva dviju različitih verzija neuronski mrežnih ART algoritama kao što su neizravne ART i ARTFC metode korištene za klasifikaciju plućnih funkcija, otkrivanje restriktivnih, opstruktivnih i normalnih uzoraka disajnih abnormalnosti putem svake neuronske mreže s podacima prikupljenim spirometrijom. Spirometrijski podaci su prikupljeni na 150 pacijenata standardnim postupkom prikupljanja, gdje se 100 ispitanika koristi za obuku i 50 za testiranje, respektivno. Rezultati su pokazali da standardi neizravni ART algoritam raste brže od ARTFC, koji uspješno rješava problem kategorizacije proliferacija.

Ključne riječi: - teorija adaptivne rezonancije
- umjetno temeljeni neizraziti klasifikatori
- teorija neizrazite adaptivne rezonancije

Abstract: An artificial neural network is a system based on the operation of biological neural networks, in other words, it is an emulation of the biological neural system. The objective of this study is to compare the performance of two different versions of neural network ART algorithms such as Fuzzy ART vs. ARTFC methods used for classification of pulmonary function, detecting restrictive, obstructive and normal patterns of respiratory abnormalities by means of each of the neural networks, as well as the data gathered from spirometry. The spirometry data were obtained from 150 patients by standard acquisition protocol, 100 subjects used for training and 50 subjects for testing, respectively. The results showed that the standard Fuzzy ART grows faster than ARTFC, which successfully solves the category proliferation problem.

Keywords: - Adaptive Resonance Theory
- Art-Based Fuzzy Classifiers
- Fuzzy Adaptive Resonance Theory

1. INTRODUCTION

An artificial neural network is a system based on the operation of biological neural networks, in other words, it is an emulation of the biological neural system [1]. The adaptive resonance theory (ART) paradigm, developed by Steven Grossberg and Gail Carpenter, is consistent with cognitive and behavioral models. This is an unsupervised paradigm that is based on competitive learning (CL), finds categories autonomously, and learns new categories if needed. The adaptive resonance model was developed to solve the problem of the instability of feed forward systems, practically the stability-plasticity dilemma. The key idea of ART is that the stability-plasticity dilemma can be resolved by a system in which the network includes bottom-up (input-output) competitive learning combined with top-down (output-

input) learning [2]. In 1976, Grossberg [3] introduced a model for explaining biological phenomena. ART encompasses a wide variety of neural networks based explicitly on neurophysiology. ART networks are defined algorithmically in terms of detailed differential equations intended as plausible models of biological neurons. ART comes in several variations, both supervised and unsupervised. As discussed by Moore [4], the unsupervised ART is basically similar to many iterative clustering algorithms in which each case is processed by: 1) Finding the “nearest” cluster seed to that case; 2) Updating that cluster seed to be “closer” to the case where “nearest” and “closer” can be defined in different ways. In ART, the framework is modified slightly by introducing the concept of “resonance” as a certain

threshold of a second similarity measure. A crucial feature of ART is that if no seed resonates with the case, a new cluster is created as in Hartigan's algorithm [5]. This feature is said to solve the stability-plasticity dilemma. The current training case is stored in short-term memory (STM) and cluster seeds in long-term memory (LTM). A cluster is a maximally compressed pattern recognition code. Stable learning means that the algorithm converges. So the often-repeated claim that ART algorithms are "capable of rapid stable learning of recognition codes in response to arbitrary sequences of input patterns" merely means that ART algorithms are clustering algorithms that converge; it does not mean that the clusters are insensitive to the sequence in which the training patterns are presented. The model has three crucial properties [1]: a normalization of the total network activity, contrast enhancement of input patterns, and STM storage of the contrast-enhanced pattern. Before the input pattern can be decoded, it must be stored in the STM. The LTM implements an arousal mechanism (i.e., the classification), whereas the STM is used to cause gradual changes in the LTM.

The system consists of two layers, F1 (the comparison layer) and F2 (the recognition layer), which are connected to each other via the LTM (Figure 1).

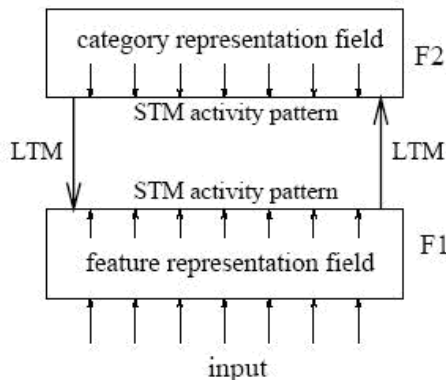

Figure 1. The ART architecture

The input pattern is received at F1, whereas classification takes place in F2. The input is not directly classified. First, a characterization takes place by means of extracting features, giving rise to activation in the feature representation field. The expectations, residing in the LTM connections, translate the input pattern into a categorization in the category representation field. The classification is compared to the expectation of the network, which resides in the LTM weights from F2 to F1. If there is a match, the expectations are strengthened, otherwise the classification is rejected. The architecture of the ART has two main layers: the first is the input/comparison layer with N nodes and the second is the output/recognition layer with M nodes. The two layers are extensively interacting with forward feed and feedback connectivity. In addition, there is an

intermediate layer, an adaptive filtering network between input and output circuits. For each layer there are control signals that control the data flow – Figure 2.

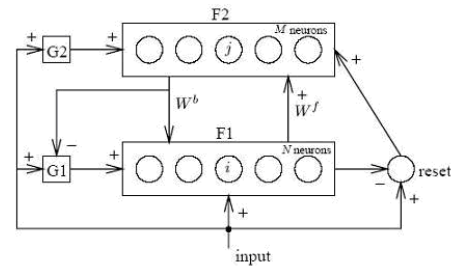

Figure 2. The ART neural network

Each neuron in F1 is connected to all neurons in F2 via the continuous-valued forward LTM W_f , and vice versa via the binary-valued backward LTM W_b . The other modules are gain 1 and 2 (G_1 and G_2), and a reset module. Each neuron in the comparison layer receives three inputs: a component of the input pattern, a component of the feedback pattern, and a gain G_1 . A neuron outputs a 1 if and only if at least three of these inputs are high. The neurons in the recognition layer each compute the inner product of their incoming (continuous-valued) weights and the pattern sent over these connections. The winning neuron then inhibits all the other neurons via lateral inhibition. Gain 2 is the logical 'OR' of all elements in the input pattern x . Gain 1 equals gain 2, except when the feedback pattern from F2 contains any 1; then it is forced to zero. The reset signal is sent to the active neuron in F2 if the input vector x and the output of F1 differ by more than some vigilance level. Carpenter and Grossberg [3] present several neural network models to incorporate parts of the complete theory. The ART network incorporates a follow-the-leader clustering algorithm by Hartigan [5]. This algorithm tries to fit each new input pattern in an existing class. If no matching class can be found, i.e., if the distance between the new pattern and all existing classes exceeds some threshold, a new class is created containing the new pattern. The novelty in this approach is that the network is able to adapt to new incoming patterns, while the previous memory is not corrupted. By changing the structure of the network rather than the weights, ART overcomes this problem. There are various supervised ART algorithms that are named with the suffix "MAP", as in the Fuzzy ARTMAP. These algorithms cluster both the inputs and targets and associate the two sets of clusters. The effect is somewhat similar to counter propagation (CP). The main disadvantage of most ARTMAP algorithms is that they have no mechanism to avoid overfitting and hence should not be used with noisy data.

Models of unsupervised learning (without teacher) include ART1 for binary input samples and Fuzzy ART for analog input samples [6]. A more specific class of

ART algorithms which combines ART principles and fuzzy logic is the one most appropriate for automatic realization. These networks are named ART Fuzzy networks (ARTFNs) and are based on two major models: Fuzzy ARTMAP (FAM) and Simpson’s Fuzzy Min-Max Network (FMMN), or they are both named as standard ARTFNs. ARTFNs join the properties of both neural and fuzzy approaches and therefore possess additional advantages such as interpretable information representation, unsophisticated implementation, few tuning parameters, and the capability of producing fuzzy if-then rules as compared to ART in a broad sense. ARTFNs are one of the ART subclasses representing neuro-fuzzy hybrids which inherit all key features of ART. Fuzzy ART is the first member in the sequence of ARTFNs. The development of a supervised extension to Fuzzy ART has produced Fuzzy ARTMAP (FAM) [7]. ARTMAP [8] is a class of neural network architectures that perform incremental supervised learning of recognition categories and multidimensional maps in response to input vectors presented in an arbitrary order. Fuzzy ARTMAP leads to favorable levels of learning, predictive accuracy, speed and code compression in both online and offline settings, it is easy to use, has a small number of parameters and requires no problem-specific system crafting or choice of initial weight values. One way in which the fuzzy ARTMAP differs from many previous fuzzy pattern recognition algorithms is that it learns each input as it is received online, rather than performing an offline optimization of a criterion function. Each ARTMAP system (Figure 3) includes a pair of adaptive resonance theory modules (ART_a and ART_b) that create stable recognition categories in response to arbitrary sequences of input patterns.

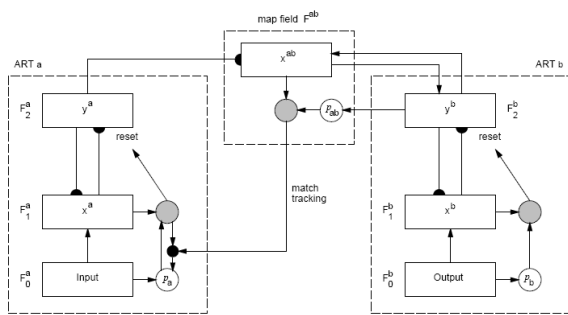

Figure 3. Fuzzy ARTMAP network architecture

During supervised learning, ART_a receives a stream {a^(p)} of input patterns, and ART_b receives a stream {b^(p)} of input patterns, where {b^(p)} is the correct prediction given a^(p). These modules are linked by an associative learning network and an incremental controller that ensures autonomous system operation in real time. The controller is designed to create the minimal number of ART_a recognition categories, or “hidden units” needed to meet accuracy criteria, by realizing a mini-max learning

rule that enables an ARTMAP system to learn quickly, efficiently and accurately as it conjointly *minimizes* predictive error and *maximizes* predictive generalization. It works by increasing the vigilance parameter ρ_a of ART_a by the minimal amount needed to correct a predictive error at ART_b. Lower values ρ_a enable larger categories to form and these values lead to broader generalization and higher code compression. A predictive failure at ART_b increases ρ_a by the minimum amount needed to trigger hypothesis testing at ART_a, using a mechanism called match tracking. Match tracking sacrifices the minimum amount of generalization necessary to correct a predictive error. Hypothesis testing leads to the selection of a new ART_a category, which focuses attention on a new cluster of a^(p) input features that is better able to predict b^(p). Fuzzy ART shows how computations from the fuzzy set theory can be incorporated naturally into ART systems. The crisp (non fuzzy) intersection operator (\cap) that describes ART1 dynamics is replaced by the fuzzy AND operator (\wedge) of the fuzzy set theory, in the choice, search, and learning laws of ART1 (Table 1). Replacing the crisp logical operators of ART1 with their fuzzy counterparts leads to a more powerful version of ART1. Whereas ART1 can learn stable categories only in response to binary input vectors, fuzzy ART can learn stable categories in response to either analog or binary input vectors. Moreover, fuzzy ART reduces to ART1 in response to binary input vectors.

Table 1. Analogy between ART1 and Fuzzy ART.

ART1 (binary)	Fuzzy ART (analog)
Choice Function (CF)	
$T_j = \frac{ I \cap w_j }{\alpha + w_j }$	$T_j = \frac{ I \wedge W_j }{\alpha + W_j }$
Match Criterion	
$\frac{ I \cap w_j }{ I } \geq \rho$	$\frac{ I \wedge W_j }{ I } \geq \rho$
Fast learning	
$w_j^{(new)} = I \cap w_j^{(old)}$	$W_j^{(new)} = I \wedge W_j^{(old)}$

In Fuzzy ART [8], learning always converges because all adaptive weights are monotonically non-increasing. Without additional processing, this useful stability property could lead to the unattractive property of category proliferation as too many adaptive weights converge to zero. A preprocessing step, called complement coding, uses on-cell and off-cell responses to prevent category proliferation. Complement coding normalizes input vectors while preserving the amplitudes of individual feature activations. Without complementing coding, an ART category memory encodes the degree to which critical features are consistently present in the training exemplars of that category. With complement coding, both the degree of absence and the degree of

presence of features are represented in the category weight vector.

Certain problems implicitly ensuing from ARTFN design such as category proliferation and manual parameter tuning problems are eliminated in Art-Based Fuzzy Classifiers (ARTFC) algorithms. A generalized ARTFN classification algorithm on the basis of FAM can be described as a sequence of four main steps: preprocessing, winner selection, a class correctness test, and a prototype update. The preprocessing step is not mandatory, it can represent, for example, the complement coding operation of FAM. Winner selection is performed by calculating a Choice Function (CF) and checking a Match Criterion. The CF values are computed for those nodes which satisfy the Match Criterion, with the winner then being chosen as a node with the maximal CF value. The CF is usually based on some distance measure. The Match Criterion is realized in ARTFNs as a maximum cluster size constraint. The class correctness test confirms the winner choice and enables learning.

The prototype update relates to the learning process which in Winner-take-all (WTA) networks is performed only for a winning prototype. Three fundamental issues are: defining the prototype shape (a method of approximation of cluster regions – a common method is the hyper rectangular cluster approximation), balancing between adjustments of old prototypes and creating new ones (CF and Match Criterion control the balance), as well as the problem of overlapping prototypes (the overlap of prototypes of different classes is not allowed in FMMN, but it is allowed in FAM).

ARTFNs can be classified into models with rectangular and with ellipsoidal regions which can provide a compact and efficient cluster approximation with Gaussian distributions and these prototypes are claimed to be more appropriate for restriction of category proliferation.

A variety of different multidimensional functions can be involved in the design of ARTFC. The main objective in implementing a particular CF in an ARTFN is to provide the choice and subsequent learning of the proper winning prototype. Values of a CF depend on the location of an input pattern in the feature space with respect to the stored cluster prototypes.

The one most commonly used in CL networks is Euclidean distance, as it is best suited to simple hyper spherical cluster shapes. Mahalanobis distance, in turn, is utilized for hyper ellipsoidal clusters. CF should satisfy several requirements to be suitable for use in an ARTFN such as: learning of a pattern A by the prototype j should increase the value of the CF for a category j, the value of the CF should decrease (increase) monotonically with an increasing distance of the input point from the prototype, an input pattern falling inside exactly one cluster prototype should be captured by that category, the CF should keep the feature space covered—otherwise an input pattern would not be captured by any category and might remain unclassified, and the CF values of point or

small prototypes should be large enough to guarantee their choice and subsequent learning.

If an input pattern lies inside several overlapping hyper boxes, the smallest of them should win. It also guarantees that a category created in response to some training pattern inside a hyper box with an incorrect class label will capture this pattern if it is immediately presented again.

Since a CF specifies how close a new input lies to each prototype, it is very important for the correct selection of a winner by the CL scheme. A Match Criterion specifying the minimal acceptable quality of coding of an input pattern by the winner is necessary to provide stability of learning. The overlapping categories could be advantageous when they are determined by the distribution of the data. Therefore the points within the overlap may be assigned to the category with lower density. A practical reason for allowing overlap between prototypes of different classes is that any nonconvex classification task can be effectively solved with nested hyper-boxes, without overlap, the hyper-boxes within other hyper-boxes cannot be created and therefore one hyper-box will encode all patterns in the circle, while several hyper-boxes will be necessary to encode the rest of the patterns.

Hyper-rectangular cluster approximation benefits from computational simplicity of learning and fuzzy rule extraction. It also enables combination with other types of cluster approximation, for example by cluster centroids. Since fast learning is very important for automatic realization of an ARTFN, its modification would also be undesirable. In order to eliminate category proliferation, the following solutions are proposed by [7]:

- Utilizing the cluster centroid positions in addition to hyperboxes,
- Non flat CFs,
- A soft Match Criterion, and
- Overlap resolution on the basis of CF values without Match Tracking.

Different ART algorithms might be applicable in medicine, and especially for detection of pulmonary functional abnormalities.

Respiratory diseases are preventable and curable by early detection. Respiratory function is commonly assessed by a standard spirometric pulmonary function test [9]. Pulmonary function test can detect the presence and degree of pulmonary functional abnormalities, differentiate between obstructive, restrictive and mixed obstructive/ restrictive pathology, help in the evaluation of the presence and degree of increased airway responsiveness, and assess the risk of therapeutic or diagnostic interventions. The test monitors the effects of therapy and contributes to an accurate prognosis of disease and disability [9, 10]. In obstructive lung conditions, the airways are narrowed, usually causing an increase in the time it takes to empty the lungs. Obstructive lung disease can be caused by conditions

such as emphysema, bronchitis, infection (which produces inflammation), and asthma. In restrictive lung conditions, there is a loss of lung tissue, a decrease in the lung's ability to expand, or a decrease in the lung's ability to transfer O_2 into the blood or CO_2 out of the blood [10, 11]. Restrictive lung disease can be caused by conditions such as pneumonia, lung cancer, scleroderma, pulmonary fibrosis, sarcoidosis, or multiple sclerosis. Other restrictive conditions include some chest injuries, being very overweight (obesity), pregnancy, and loss of lung tissue due to surgery [11 - 13]. Indications for spirometry should be based on a careful history and physical examination. Spirometry is also valuable in evaluating the effectiveness of treatment, both acutely and over time. Specific indications for spirometry include [9]: establishing the presence of ventilatory dysfunction, ongoing evaluation of known ventilatory dysfunction, monitoring for potential ventilatory dysfunction, patient self monitoring, and screening for early diagnosis of ventilatory dysfunction in populations at risk. Spirometry may help support clinical evaluation of individuals with a smoking history or other risks of developing pulmonary dysfunction [13] (Figure 4).

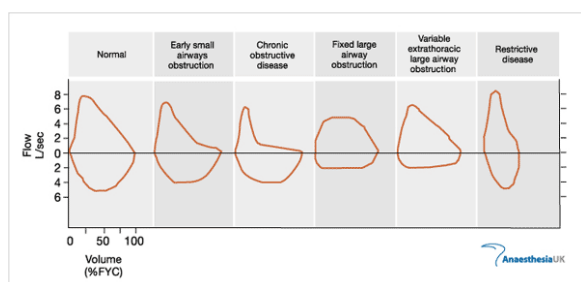

Figure 4. Pulmonary dysfunction

The first attempts at recording what we now understand to be lung function were in 1679 when Giovanni Borelli inverted a bowl in water and blew through a tube, elevating it to determine how much air came from a breath. Thackrah in 1832 presented the first data on spirometric function and concluded that subjects with a stoop had smaller lungs. Hutchinson is usually attributed as the founder of current spirometry with his measure of VC [15]. Bain in 1870 [16] described the first portable spirometer (wedge-bellows design) and the first dynamic test of lung function was proposed by Hermanssen in 1933 [17] as the maximum voluntary ventilation (MVV). Tiffeneau [18] proposed the measure of forced expired volume at 1 second as a measure of dynamic function, but Gaensler [19] put FEV1 on the map by finding that of FEV_n, for various values of n, that it was FEV1 that best correlated with the then best test of MVV. Higgins [20] was the first to present data using a PEF meter and correlated this with an indirect measurement of MVV using FEV0.75 data.

Spirometry is the measurement of the flow and volume of air entering and leaving the lungs. It includes, but is not limited to, the measurement of Vital Capacity (VC), Forced Vital Capacity (FVC), Slow Vital Capacity (SVC), Forced Expiratory Volume in 1 sec (FEV1), FEV1/FVC, Peak Expiratory Flow (PEF), Maximum voluntary ventilation (MVV), Forced expiratory flow 25-75 % (FEF25-75 %), Tidal volume (TV), Functional residual capacity (FRC), Residual volume (RV), Total lung capacity (TLC), Expiratory reserve volume (ERV), Inspiratory capacity (IC), and Inspiratory reserve volume (IRV) [14, 21]. The equipment used in performing spirometry, the personnel performing the test, as well as the establishment of predicted normal values and interpretation of the results must meet the most recently published standards of the American Thoracic Society (ATS) [11]. The spirometric indices [22] are shown in Figure 5.

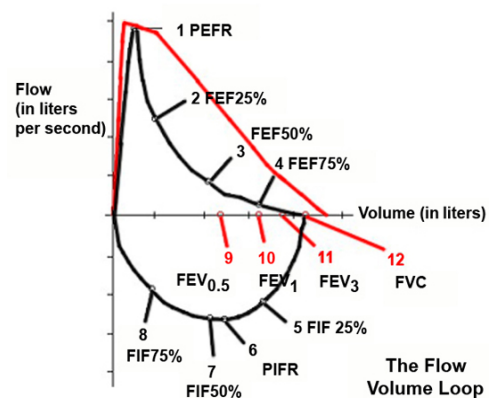

Figure 5. The Flow Volume Curve

Interpretation of pulmonary function tests is usually based on comparisons of data measured in an individual patient or subject of reference (predicted) values based on healthy subjects. Predicted values should be obtained from studies of "normal" or "healthy" subjects with the same anthropometry (e.g., sex, age, and height) and, where relevant, ethnic characteristics of the patient being tested [23]. In Europe, the combined reference equations published in the 1993 ERS statement are often used for 18-70 yr old people with a height range of 155-195 cm in men, and 145-180 cm in women and those from Quanjer et al in pediatric ages [24]. Reference equations need to be correctly used and periodically updated, but measured values outside of the normal range may not necessarily indicate lung disease. Fundamental steps for quality control of spirometry are the assessments of acceptability (within maneuver evaluation) and repeatability (between maneuver evaluations) of the tests. For optimal quality control, both flow-volume and volume-time displays are useful and test operators should visually inspect the performance of each maneuver for quality assurance before proceeding with another maneuver [21]. In

conclusion, both volume-time and flow-volume curves are required in order to ensure quality control of spirometry by numerical and visual inspection.

The objective of this study is to compare the performance of two different versions of neural network ART algorithms such as Fuzzy ART vs. ARTFC methods used for classification of pulmonary function. Also, the present article aims at detecting restrictive, obstructive and normal patterns of respiratory abnormalities by means of each of the neural networks, Fuzzy ART and ARTFC as well as the data gathering from spirometer. Mild levels of obstructive and restrictive patterns of pulmonary diseases are quite similar to normal patterns; hence, their early diagnosis is of importance since early diagnosis of mild respiratory diseases by means of neural networks may prevent the spread of pulmonary diseases to a critical phase and thus may be of utmost importance in a medical context.

2. MATERIALS AND METHODS

2.1. Subjects

The study included 150 adult examinees (71 males and 79 females), mean age $54,2 \pm 9,7$ years; range (19 – 87 years). The spirometry data analysis showed that 28 subjects are with normal values, 81 subjects are obstructive and 41 are restrictive, respectively.

2.2. Spirometry testing

Spirometry, including measurements of forced vital capacity (FVC), forced expiratory volume in a one second (FEV1), FEV1/FVC ratio, maximal expiratory flow at 75 %, 50 %, 25 % and 25 % to 75 % of FVC (MEF75, MEF50, MEF25 and MEF25-75, respectively), and peak expiratory flow (PEF) were taken using the spirometer Ganshorn SanoScope LF8 (Ganshorn Medizin Electronic GmbH, Germany) in all subjects, and the best of the three measurements was recorded. Additional parameters taken into consideration were: vital capacity inspiration - VC_{in}, vital capacity expiration – VC_{ex}, forced vital capacity inspiration - FVC_{in}, forced vital capacity expiration – FVC_{ex}, the area under the maximum expiratory flow-volume curve - AREA_{ex}. The results were expressed as percentages of predicted values set by the European Community for Coal and Steel (ECCS) norms [24]. Obstructive lung function impairment was determined when FEV1 was less than 80 % of predicted value, whereas restrictive impairment was defined by VC_{max} as less than 80 % of predicted value. We considered three stages of obstructive lung disorders according to the FEV1 value (mild: 60-80 %, moderate: 45-60 % and severe: <45 % obstruction), as well as three stages of restrictive pulmonary disorders considering the VC_{max} value (mild: 65-80 %, moderate: 50-65 % and severe: <50 % restriction).

2.3. Methods for analyzing spirometry data

All pulmonary subjects' parameters were entered manually using spirometer printouts. Spirometry data were analyzed with descriptive and inferential statistical methods using SPSS release 12. Descriptive statistical analysis included tables and figures containing statistical series according to the defined variables. Continuous variables were expressed as mean values with standard deviation (SD) and nominal variables as numbers and percentages. Subjects were clustered according to the ART algorithm of neural networks [25]. The algorithm was implemented using MATLAB 6.1 Release 12.1. The network has a number of neuron-like processing units organized in layers. Each neuron in one layer is connected to all neurons of the other; the comparison layer via the continuous-valued forward LTM and vice versa via the binary-valued backward LTM. The neurons in the recognition layer each compute the inner product of their incoming (continuous-valued) weights and the pattern sent over these connections. The data enters at the input and passes through the network, layer by layer, until it arrives at the output. The parameters of the network were adjusted by training the ART network on a set of a reference data, called the training set. The trained networks were then used to predict categories (clusters) of the new data. The important functions in MATLAB that are used to modularize the structure of the system are: ART_Activate_Categories that essentially provide bottom-up activation of the F2 layer for a given input; the ART_Add_New_Category is used following a series of mismatch resets in order to create a new F2 neuron to code the current input; ART_Calculate_Match is used to determine the degree of match between a given input and the category coded by the current F2 neuron; ART_Update_Weights is used to update the weight matrix during learning after resonance has been achieved. Similar functions are used for the ARTFC algorithm where determination of the match degree is based on Choice Function, i.e. how new input lies in relation to each prototype by calculating an overlap coefficient of two or more hyper-boxes. According to that coefficient, a small number of categories are provided. The function for adding new categories ensures that the input pattern will be put into correct hyper-box and that others may remain unclassified.

The performance of the neural networks was estimated using False positive (FP), False Negative (FN), True Positive (TP) and True Negative (TN) values [26]. Classification of normal data as abnormal is considered as FP and classification of abnormal data as normal is considered FN. TP and TN are the cases where the abnormal is classified as abnormal and normal classified as normal respectively. The accuracy, sensitivity, specificity and adjusted accuracy were estimated using the following relation:

$$\begin{aligned} \text{Accuracy} &= (\text{TP}+\text{TN}) / (\text{TP}+\text{FP}+\text{TN}+\text{FN}) \\ \text{Sensitivity} &= \text{TP} / (\text{TP}+\text{FN}) \\ \text{Specificity} &= \text{TN} / (\text{TN}+\text{FP}) \\ \text{False Positive Rate} &= \text{FP} / (\text{TN} + \text{FP}) \\ \text{Positive Predictive Value} &= \text{TP} / (\text{TP} + \text{FP}) \\ \text{Negative Predictive Value} &= \text{TN} / (\text{TN} + \text{FN}) \\ \text{Adjusted accuracy} &= (\text{sensitivity} + \text{specificity}) / 2. \end{aligned}$$

Accuracy is the representation of classifier performance in a global sense. Sensitivity and specificity are the proportions of abnormal data classified as abnormal, and normal data classified as normal respectively. The adjusted accuracy is a measure that accounts for unbalanced sample data of normal and abnormal events. The adjusted accuracy combines sensitivity and specificity into a single measurable value [26].

3. RESULTS AND DISCUSSION

In order to train the ART neural networks, Fuzzy ART and ARTFC, 100 subjects with different types of lung function tests were taken into consideration. Another 50 subjects with various kinds of pulmonary function tests were used for testing the same network. The descriptive statistical analyses of the input to the neural network are shown in Table 2 for subjects with normal spirometry parameters, and Table 3 for subjects with abnormal pulmonary parameters. The tables show percentage predicted values of the input data from 100 subjects taken for training the neural network.

Table 2. Normal spirometry parameters

	Mean (%)	SD (%)	SE (%)
Vcin	89,26	16.80	4.34
Vcex	104,66	10.54	2.72
Vcmax	105,46	10.77	2.78
FEV1	105,2	9.21	2.38
FEV1/Vcmax	81,73	6.55	1.69
FVCex	105,4	10.23	2.64
FVCin	91,8	17.15	4.43
MEF25	105,66	36.70	9.48
MEF50	95,73	21.63	5.58
MEF75	95,6	15.90	4.11
MEF25_75	98,66	20.53	5.30
MEF75_50/50_25	186,86	37.81	9.76
PEF	90,2	14.62	3.77
FEV1/VCex	84,8	8.01	2.07
AREAex	134,26	21.28	5.49
MIF50/MEF50	110,46	48.72	12.58

The mean values of the spirometer parameters for normal subjects are significantly higher than those of the abnormal case. The standard deviation and the standard

error also show distinct changes. These spirometer values are given into the neural networks for training purposes and also for validation. First, Fuzzy ART was evaluated. The input was enlarged for their complements and the result of learning after creating the network was 48 categories for 100 subjects, with a vigilance parameter 0.75 and bias = 0.000001. The number of epochs needed was 20. Those clusters are shown in the Figure 6.

Table 3. Abnormal spirometry parameters

	Mean (%)	SD (%)	SE (%)
Vcin	57,24	13.16	1.43
Vcex	68,8	13.65	1.48
Vcmax	69,68	13.86	1.50
FEV1	63,7	15.59	1.69
FEV1/Vcmax	72,08	14.08	1.53
FVCex	69,94	13.40	1.45
FVCin	58,71	13.46	1.46
MEF25	59,8	38.47	4.17
MEF50	51,42	29.89	3.24
MEF75	51,44	23.92	2.59
MEF25_75	53,64	29.15	3.16
MEF75_50/50_25	205,9	45.34	4.92
PEF	56,67	19.26	2.09
FEV1/VCex	74,37	13.53	1.47
AREAex	53,75	24.28	2.63
MIF50/MEF50	156,38	128.82	13.97

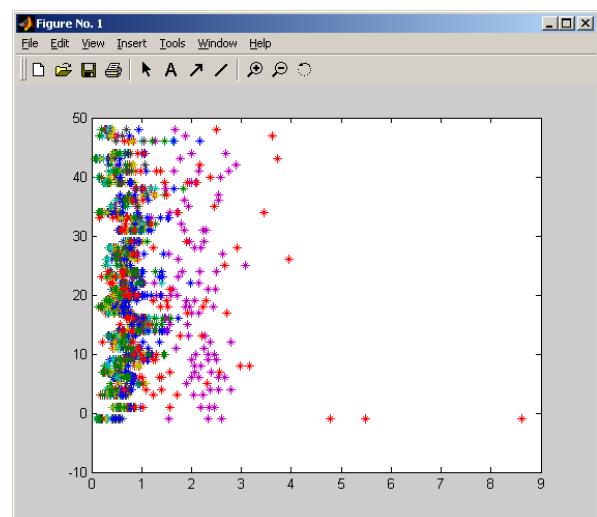

Figure 6. Results of categorization of 100 training subjects

Input of another 50 testing subjects, after enlarging the input set with their complements, is categorized and the results are shown in Figure 7.

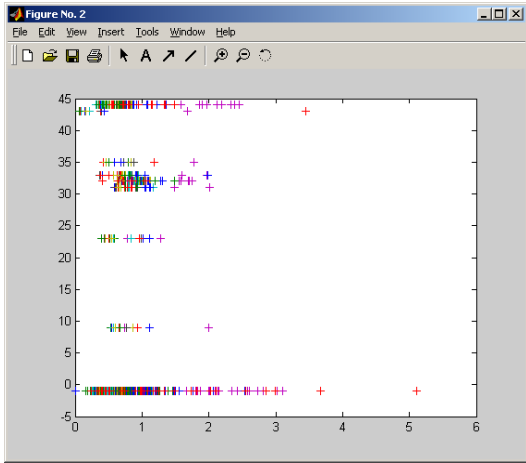

Figure 7. Results of categorization of 50 testing subjects

The results of categorization are also shown in the Table 4. These are results for the testing input (50 subjects) and how they were matched according to the previously defined clusters. This matrix of results was parsed to distinguish normal (matrix matN50) and abnormal (obstructive (matrix matO50) and restrictive (matrix matR50)) results. It is important to know that only two subjects were not categorized according to the previously defined clusters, and they are represented by -1, one for normal and one for abnormal, but they are already incorporated into FN and FP (Table 5). The representation in Table 5 was made according to the applied methodology for performance of a neural network.

Table 4. Categorization results

Testing category	Results of categorization
newCat	Columns 1 through 16 -1 44 35 23 33 -1 43 -1 32 -1 -1 -1 44 -1 -1 44 Columns 17 through 32 -1 -1 32 32 -1 44 -1 -1 32 9 33 44 -1 -1 44 31 Columns 33 through 48 32 -1 31 44 -1 44 -1 -1 -1 -1 -1 -1 -1 44 -1 44 Columns 49 through 50 -1 -1
matN50	Columns 1 through 16 0 0 0 0 0 0 0 0 0 32 0 0 -1 0 0 -1 0 Columns 17 through 32 0 -1 32 32 0 0 0 -1 32 0 0 0 -1 0 0 0 Columns 33 through 48 32 0 0 0 0 0 0 0 0 -1 0 -1 0 0 0 0 Columns 49 through 50 -1 0

matO50	Columns 1 through 16 0 0 35 0 0 -1 43 -1 0 -1 -1 0 44 -1 0 44 Columns 17 through 32 -1 0 0 0 0 44 0 0 0 9 0 44 0 0 44 0 Columns 33 through 48 0 -1 0 44 -1 44 -1 -1 0 0 -1 0 -1 44 -1 44 Columns 49 through 50 0 0
matR50	Columns 1 through 16 -1 44 0 23 33 0 0 0 0 0 0 0 0 0 0 0 Columns 17 through 32 0 0 0 0 -1 0 -1 0 0 0 33 0 0 -1 0 31 Columns 33 through 48 0 0 31 0 0 0 0 0 -1 0 0 0 0 0 0 0 Columns 49 through 50 0 -1

Table 5. Results according the applied method for Fuzzy ART

	<i>Normal</i>	<i>Abnormal</i>	Total
Predictio	TP = 5	FP = 13+6 =	24
n		19	
False	FN = 8	TN = 12+6 =	26
Negative		18	
Total	13	37	50

The next neural network that was analyzed was ARTFC. The same input of 100 subjects was used and similar to Fuzzy ART, the input was enlarged for their complements and the result of learning after creating the network was 10 categories for 100 subjects, with a vigilance parameter 0.75 and bias = 0.000001. The number of epochs needed was 93. Those clusters are shown in Figure 8.

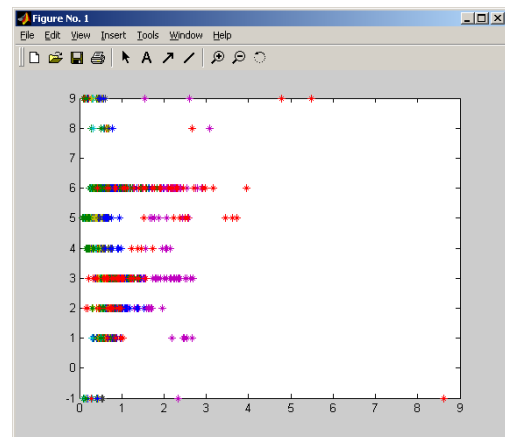

Figure 8. Results of categorization of 100 training subjects

Input of another 50 testing subjects, after enlarging the input set with their complements, was categorized and the results are shown in Figure 9.

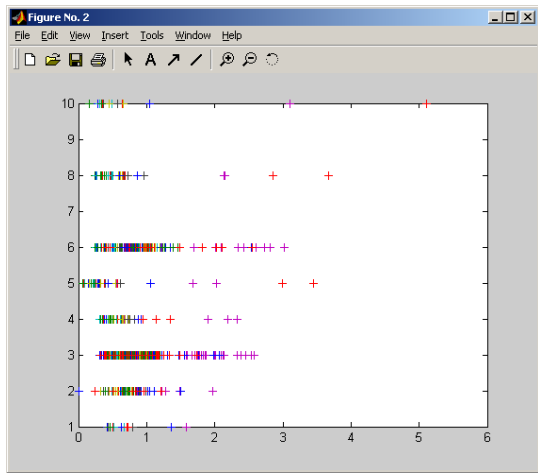

Figure 9. Results of categorization of 50 testing subjects

The results of categorization are also shown in the Table 6. These are results for the testing input (50 subjects) and how they are matched to the previously defined clusters. This matrix of results was parsed to distinguish normal (matrix matN50), abnormal (obstructive (matrix matO50), and restrictive (matrix matR50)) results. There were no uncategorized categories according to the previously defined clusters (Table 7). The representation in the Table 8 was made according to the applied methodology for performance of a neural network.

Table 6. Categorization results

Testing category	Results of categorization
newCat	Columns 1 through 16 3 3 3 2 2 3 5 6 3 3 3 6 4 3 6 4
	Columns 17 through 32 8 6 3 3 3 4 3 3 3 3 3 1 3 2 3 3
	Columns 33 through 48 6 3 2 3 2 3 10 5 8 3 6 6 6 2 6 3
	Columns 49 through 50 6 3
	matN50
matN50	Columns 1 through 16 0 0 0 0 0 0 0 0 3 0 0 6 0 0 6 0
	Columns 17 through 32 0 6 3 3 0 0 0 3 3 0 0 0 3 0 0 0
	Columns 33 through 48 6 0 0 0 0 0 0 0 0 3 0 6 0 0 0 0
	Columns 49 through 50 6 0

matO50	Columns 1 through 16 0 0 3 0 0 3 5 6 0 3 3 0 4 3 0 4
	Columns 17 through 32 8 0 0 0 0 4 0 0 0 3 0 1 0 0 3 0
	Columns 33 through 48 0 3 0 3 2 3 10 5 0 0 6 0 6 2 6 3
	Columns 49 through 50 0 0
	matR50
matR50	Columns 1 through 16 3 3 0 2 2 0 0 0 0 0 0 0 0 0 0 0
	Columns 17 through 32 0 0 0 0 3 0 3 0 0 0 3 0 0 2 0 3
	Columns 33 through 48 0 0 2 0 0 0 0 0 8 0 0 0 0 0 0 0
	Columns 49 through 50 0 3

Table 7. Results according the used method for ARTFC

	Normal	Abnormal	Total
Prediction	TP = 13	FP = 0	13
False Negative	FN = 0	TN = 25+12 = 37	37
Total	13	37	50

The performances of the networks, Fuzzy ART and ARTFC, are calculated by giving the test data. Table 8 shows the comparison of the performance of Fuzzy ART and ARTFC neural networks. It is observed that the ARTFC has better accuracy than Fuzzy ART.

Table 8. Comparison of Fuzzy ART and ARTFC

	Fuzzy ART	ARTFC
Accuracy = (TP+TN) / (TP+FP+TN+FN)	60 %	100 %
Sensitivity = TP / (TP+FN)	61,5 %	100 %
Specificity = TN / (TN+FP)	59,5 %	100 %
False Positive Rate = FP / (TN + FP)	40,5 %	0
Positive Predictive Value = TP / (TP + FP)	34,7 %	100 %
Negative Predictive Value = TN / (TN + FN)	81,5 %	100 %
Adjusted accuracy = (sensitivity + specificity) / 2	60,5 %	100 %

These results show that the standard Fuzzy ART grows faster than ARTFC, which successfully solves the category proliferation problem. The ARTFC algorithm is more effective according to parameters such as accuracy, sensitivity, specificity, false positive rate, positive predictive value, negative predictive value and as well as adjusted accuracy. Also the number of categories formed in ARTFC decreases compared to the Fuzzy ART neural network. This result is provided using the same vigilance parameter and the same bias. Spirometry data are very noisy and the task—detection of pulmonary function abnormalities, combines high input dimensionality with relatively few data patterns, which makes them difficult to solve, but ARTFC algorithm categorizes the input data in a smooth way.

4. CONCLUSION

A neural network is an instrument that allows patterns of difference between defined groups to be learned and then applied to new test data to see if the learned pattern offers a better discrimination than that of the human observer. Neural networks are not governed by any laws of causality or association between data. They excel at pattern recognition by coping with noisy data, and during training they assess all interactions between input indices. They are thus able to classify data when the discrimination boundary between categories is highly complex [27].

Respiratory diseases have an increasing prevalence throughout the world in the past few decades [12]. A large number of cases are left sub diagnosed or even misdiagnosed, and many patients are sub treated. Therefore, lung function testing plays an important role in diagnosis, prognosis, mass screening of respiratory disorders and spirometric investigations remain central in clinical practice. In order to improve the current situation, constant attempts are being made to utilize artificial intelligence methods for classification of the pulmonary function data [28]. This study classifies the spirometric data into normal and abnormal cases, using artificial neural networks in detail. The performance comparisons of two neural network algorithms are assessed.

It is observed that ARTFC networks have better accuracy when compared to Fuzzy ART networks. The value of specificity shows that ARTFC classifies abnormal data more accurately than the Fuzzy ART network. The positive predictive value suggests that the classification of spirometric data as normal is higher in the ARTFC than that of the Fuzzy ART network. The negative predictive value indicates that the Fuzzy ART network diagnoses the normal data more correctly than the abnormal data; whereas both the normal and abnormal data are correctly diagnosed in the ARTFC network.

Manoharan et al. [28] used the comparison of back propagation and the radial basis function neural network for subjects with pulmonary measures data. The accuracy

of the radial basis function neural network is better than the back propagation network, but according to the results, the ARTFC network has better accuracy than both of them.

It appears that the Artificial Neural Network could be a valuable alternative to statistical methods. The proposed methodology could be effective for mass screening and surveying of respiratory function gross abnormalities in primary care settings. An automatic analysis based on an algorithm using neural networks with more input parameters may be useful for accurate diagnosis of such disorders. The proposed methodology may also be used in other medical disciplines for diagnostic purposes, such as to predict whether a patient will develop diabetes or not, or in a financial setting, especially in banking for loans approval. On the other hand, further improvement of this system could be provided by development of an interface between the instrument and the database using the HL7 protocol (Health Level 7) as a standard for patients' information interchange.

REFERENCES

- [1] Artificial Neural Network – Artificial Intelligence Technologies Tutorial. Adaptive Resonance Theory. Available at: <http://www.learnartificialneuralnetworks.com/art.html>
- [2] Kartalopoulos S.V. Understanding Neural Networks and Fuzzy Logic – Basic Concepts and Applications, New Jersey, IEEE Press Marketing; 1996. Carpenter G. A, Grossberg S. Learning, Categorization, Rule Formation, and Prediction by Fuzzy Neural Networks, In Chen C.H, ed: Fuzzy Logic and Neural Network Handbook, NY: McGraw-Hill. 1996: pp. 1.3-1.45.
- [3] Moore B. ART 1 and Pattern Clustering. In: Touretzky D, Hinton G, Sejnowski T, eds. Connectionist Models Summer School. San Mateo, CA: Morgan Kaufmann. 1988; 174 -185.
- [4] Hartigan J.A. Clustering Algorithms, NY: Wiley. 1975.
- [5] Kulakov A., *Data Management in Wireless Sensor Networks*. [In Macedonian]. Doctoral thesis. University Sts Cyril and Methodius, FEIT. Skopje.
- [6] Sapojnikova E. ART-based Fuzzy Classifiers: ART Fuzzy Networks for Automatic Classification. Doctoral thesis. Department of Computer Engineering at the University of Tübingen Germany; 2003.
- [7] Carpenter G, Grossberg S, Markuzon N, Reynolds J, Rosen D. Fuzzy ARTMAP: A Neural Network Architecture for Incremental Supervised Learning of Analog Multidimensional Maps. IEEE Transactions on Neural Networks. 1992; Vol. 3 (5): 698-713.

- [8] AARC Clinical Practice Guidelines: Spirometry, 1996 update. *Resp Care* 1996; 41:629-636.
- [9] American College of Physicians: Preoperative pulmonary function testing. *Ann Intern Med* 1990; 12:793-794.
- [10] American Thoracic Society: Standardization of spirometry, 1994 update. *Am J Respir Crit Care Med* 1995; 152:1107-1136.
- [11] Badgett RG, Tanaka DJ, Hunt DK et al: Can moderate chronic obstructive pulmonary disease be diagnosed by historical and physical findings alone? *Amer J Med* 1993; 94:188-196.
- [12] Crapo RO: Pulmonary function testing. *N Engl J Med* 1994; 331:25-30.
- [13] CTS Position Statement: Pulmonary physiology laboratory personnel qualifications. California Thoracic Society, 1998.
- [14] Hutchinson J. *Lancet* 1844; 1: 567-70, & 594-597
- [15] Bain WP. On a portable spirometer. *Br Med J* 1870; 1: 129
- [16] Hermannsen J. *Z Ges Exper Med* 1933; 90: 130-137
- [17] Tiffeneau R, Pinelli. Air circulant et air captif dans l'exploration de la fonction ventrilaire pulmonaire *Paris Med* 1947; 37: 624-8
- [18] Gaensler E.A. Mechanics of airflow in health and in emphysema. *Am Rev Tuberc* 1951; 64: 256-278.
- [19] Higgins ITT. Respiratory symptoms, bronchitis and ventilatory capacity in a random sample of an agricultural population. *Br Med J* 1957; 2: 1198-1203
- [20] Miller, M.R., et al. Standardisation of spirometry. ATS/ERS task force: standardization of lung function testing. *ERJ* 2005; 26:319-338.
- [21] Pellegrino R, Viegi G, Brusasco V, Crapo RO, Burgos F, Casaburi R, Coates A, van der Grinten CP, Gustafsson P, Hankinson J, Jensen R, Johnson DC, Macintyre N, McKay R, Miller MR, Navajas D, Pedersen OF, Wanger J. Interpretative strategies for lung function tests. *Eur Respir J* 2005; 26: 948-968.
- [22] Pellegrino R, Decramer M, van Schayck CP, Dekhuijzen PN, Troosters T, van Herwaarden C, Olivieri D, Del Donno M, De Backer W, Lankhorst I, Ardia A. Quality control of spirometry: a lesson from the BRONCUS trial. *Eur Respir J* 2005; 26:1104-1109.
- [23] Quajner PhH, editor. Standardization of lung function tests – 1993 update. Report Working Party for the European Community for Steel and Coal. Official Statement of the European Respiratory Society. *Eur Respir J* 1993;16(Suppl):1-100.
- [24] Bartfai G. Hierarchical Clustering with ART Neural Networks. In: Proceedings of IEEE World Conference on Computational Intelligence, Orlando, Florida; 1994.
- [25] Baemani J.M, Monadjemi A, Moallem P. Detection of Respiratory Abnormalities Using Artificial Neural Networks. *Journal of Computer Science* 2008; Vol.4 (8): 663-667.
- [26] Bright P, Miller M, Franklyn J, Sheppard M. The use of a Neural Network to Detect Upper Airway Obstruction Caused by Goiter. *Am J Respir Crit Care Med*. 1998; Vol. 157: 1885-1891.
- [27] Manoharan S.C, Veezhinathan M, Ramakrishnan S. Comparison of Two ANN Methods for Classification of Spirometer Data. *Measurement science review* 2008; Vol.8 (2), No.3: 53-57.

Primljeno / Received: 15.02.2009.

Prihvaćeno / Accepted: 10.06.2009.

Izvorno znanstveni članak

Original Scientific Paper

Authors' address Aneta Mirceska
Faculty of Electrical Engineering and Information
Technology, University Sts. Cyril and Methodius Skopje
Tone Tomsic 18-3/14
1000 Skopje, R. MACEDONIA
amirceska@yahoo.com