

Feasibility of decreasing pipe sticking probability using nanoparticles

A. M. Paiaman and B. D. Al-Anazi

PROFESSIONAL PAPER

This paper presents a new method to prevent stuck pipe or at least to decrease its probability while drilling of oil and gas wells. This method which is applicable in both vertical and deviated wells incorporates using nanoparticles in drilling mud composition to decrease mud cake thickness. So by having less mud cake thickness, probability of stuck pipe decreases. Also different mechanisms of stuck pipe in Ahwaz and Abb-Taymoor oil fields (SW Iran) are considered and a new approach is suggested to use, while drilling of most sensitive formations in respect to stuck pipe in these oil fields.

Key words: stuck pipe, mud cake, drilling mud, nanoparticles, friction

1. Introduction

Drilling an oil or gas well requires a drill string consisting of pipes and collars to transmit the torque provided at the surface to rotate the bit and to transmit the weight necessary to drill the formation. The driller and the directional driller steer the well by adjusting the torque, pulling and rotating the drill string. When the drill string is no longer free to move up, down, or rotate as desired, the drill pipe is stuck. Sticking can occur while drilling, making a connection, logging, testing, or during any kind of operation which involves leaving the equipment in the hole.

A stuck drill string is generally caused by the drill pipe sticking to the mud cake on the wall of the well bore due to filtrate loss in wall of the well or due to cuttings settling back into the well bore when drill fluid circulation is stopped. Stuck pipe is also possible when hydrostatic head is lower than necessary.⁵

In other words, the drill string is stuck when the static force necessary to make it move exceeds the capabilities of the rig or the tensile strength of the drill pipes. Stuck pipe can result in breaking a part of the drill string in the hole, thus losing tools in the hole that requires time and cost to perform fishing job, of course if it works.

A few variables must be taken into account when dealing with stuck pipe: pore pressure of the formation, mud system and the depth versus time (the longer in the hole without action, the more likely to get stuck). The results of a stuck pipe are very costly and include:

- Lost drilling time when freeing the pipe.
- Time and cost of fishing: trying to pull out of the hole the broken part of the BHA.
- Abandon the tool in the hole it is very difficult or too expensive to remove it.

Fig. 1. illustrates a differential sticking. Suppose that the stick-point is in a straight-hole section. The force normal to the stuck point is the component of the weight of the pipe plus the hydraulic force that causes differential sticking.

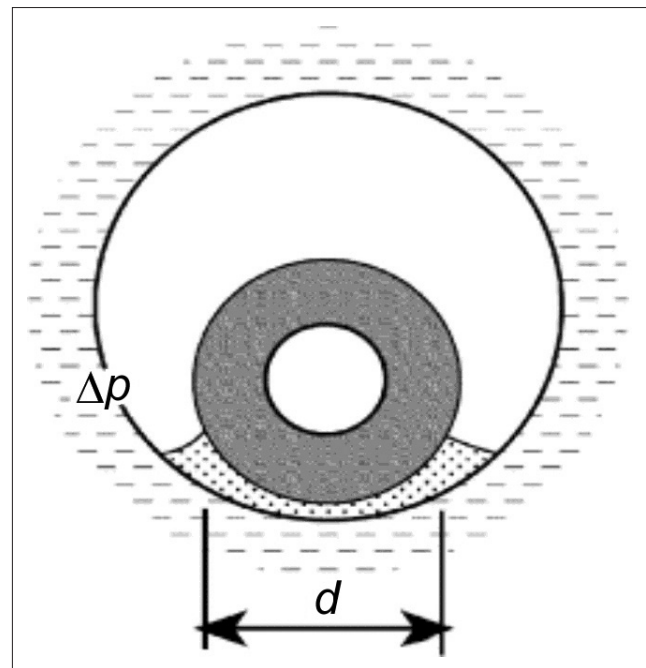

Fig. 1 Differential sticking in a well bore
Sl. 1. Diferencijalni prihvata u kanalu bušotine

Therefore due to many problems that are along with stuck pipe, many attempts have been done to find solutions for stuck pipe problem.

2. Causes of stuck pipe in Ahwaz and Abb-Taymoor oil fields

Daily reports of drilling operations and experienced drillers say that most of the stuck drill pipes in formations of Asmari, Sravak and Ilam in Ahwaz and Abb-Taymoor oil fields have happened during Pull Out of Hole, Run in Hole, while drilling, survey and connection.³

Among mentioned causes of stuck pipe, the worst case is stuck pipe while drilling. This type of stuck pipe

happens while drilling in fractured and faulted formations. Bit or bit cones get stuck in these fractures and become unable to move, or in differential pressure environment this kind of sticking is initiated by differential sticking. Asmari, Sarvak and Ilam are fractured formations of this type.⁴

These natural fractures in Asmari, Sarvak and Ilam formations are due to tectonic activities within their geology age (after diagenesis up to this time). Such systems can often be found near faults. Rock near faults can be broken into large or small pieces. If they are loose they can fall into the well bore and jam the string in the hole. Even if the pieces are bonded together, impacts from the BHA due to drill string vibration can cause the rock fragments to fall into the well bore.

3. Discussion

We look at the stuck pipe problem from mechanical engineering point of view. As it is shown in Fig. 2, some forces are acting on a drill string which is stuck against the well bore.

In which symbols in above figure represent:

T: tension forces acting on drill pipe

S: side force

B: apparent weight of the element in the mud.

It is known that when two surfaces are in contact with a perpendicular side force acting between them, any attempt to move one surface relative to the other will result in a friction force resisting the motion. So in the case that drill string rests against well bore, there is a contact between mud cake on well bore and outer surface area of drill string.

More contact area between drill string and mud cake causes more friction force resisting the motion and more difficulty to free stuck string.

Therefore we assume that two jobs can be done in order to reduce friction force resisting the motion:

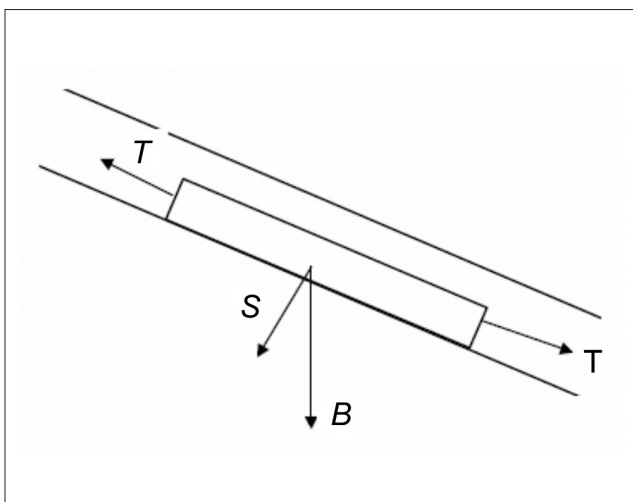

Fig. 2. Schematic diagram of a stuck drill pipe
Sl. 2. Shematski prikaz prihvata bušaće cijevi

- Reducing outer surface area of drill string: this job requires using spiral drill collars which have less outer surface area and is beneficent to some extent.
- Reducing thickness of mud cake (which is our goal in this paper).

It is known that presence of ordinary materials in drill mud can cause increased viscosity and mud weight.² This high mud weight can cause damage to sub-surface formations, plugging of production zones, hole erosion, decreased penetration rate, pipe failures, stuck pipe and lost circulation (, , and Njobuenwu and Nna, 2005). So in order to decrease probability of stuck pipe we have to use new materials in which do not increase viscosity and mud weight very much. Because as mentioned this increase in viscosity and mud weight may lead to some problems that one of them is stuck pipe.

Our suggestion for decreasing probability of stuck pipe is to use nanoparticles in drilling mud that causes several changes in mud properties. These nanoparticles are carbon black particles in which are added to drilling mud to perform some functions.

Specific gravity of carbon black is typically 1.9 - 2.1 (water=1).⁶ As it is shown in Table 1, estimated initial diameter of carbon black particles is about 30 nanometer in which after aggregation this value will be about 150 to 500 nanometer.¹

Table 1. Average size of carbon black particles⁴

| Stages of forming carbon black | Initial particles | Initial aggregates |
|--------------------------------|-------------------|--------------------|
| Estimated diameter | 30 nanometer | 150-500 nanometer |

This advantage of carbon black which has nanometer size particles causes to make a mud cake which is more continuous and integrated (it means that mud cake has low permeability). So by having integrated and low permeability mud cake, we have less volume of filtrate and therefore mud cake thickness is less than in usual cases.¹

As mentioned, presence of carbon black particles reduces the thickness of the mud cakes. The uniform individual particle size distribution provided better compaction medium which restricted the flow of filtrate from the drilling fluid.

Tables 2 and 3 show experimental data pertinent to using nanoparticles (In this case carbon black) in drilling fluid. Important point is that carbon black particles have thermal stability up to 3 000 °F (1 649 °C).

Based on Tables 2 and 3, condition of mud cake thickness and mud rheological properties are discussed in different temperatures and pressures. As it is clear, adding carbon black to 13.5 ppg (1.62 kg/l) water based drilling mud has decreased mud cake thickness. As temperature and pressure go up, this improvement in thickness reduction is better. Also experimental data shows reduction in mud viscosity and yield point.

4. Results and conclusion

Using nanoparticles in drilling mud which is a branch of nanotechnology has several advantages. Carbon black is one of the nanomaterials in which is produced inside Iran and is available and in access. Trying to use carbon black particles in drilling mud showed useful results. The main advantage that in this paper was discussed is decrease in mud cake thickness. Less mud cake thickness will lead to less probability of stuck pipe. Also causes of stuck pipe in some sensitive formations in Ahwaz and Abb-Taymoor oil fields were discussed and we conclude that our suggestion works and is useful to use in Iran oil industry to decrease probability of stuck pipe while drilling, cost and time.

4. Results and conclusion

Using nanoparticles in drilling mud which is a branch of nanotechnology has several advantages. Carbon black is one of the nanomaterials which is produced inside Iran and is available and in access. Trying to use carbon black particles in drilling mud showed useful results. The main advantage discussed in this paper is decrease in mud cake thickness. Less mud cake thickness will lead to less probability of stuck pipe. Also causes of stuck pipe in some sensitive formations in Ahwaz and Abb-Taymoor oil fields were discussed and we conclude that our suggestion works and is useful to use in Iran oil industry to decrease probability of stuck pipe while drilling, cost and time.

Table 2. Effect of nanoparticles on reduction of mud cake thickness⁴

| Pressure & Temperature | Initial mud cake thickness | Adding 2% by volume of carbon black to mud | Percentage of improvement |
|--|----------------------------|--|---------------------------|
| 6.89 bar, 27 °C (100 psi, 80 °F) | 3.18 mm (4/32 in.) | 2.38 mm (3/32 in.) | 25% |
| 34.47 bar, 148.9 °C (500 psi, 300 °F) | 8.73 mm (11/32 in.) | 6.35 mm (8/32 in.) | 27% |

Table 3. Effect of nanoparticles on reduction of mud viscosity and yield point²

| Cases of experiment | Initial mud at 37.78 °C (100 °F) | Adding 2% by volume of carbon black to mud | Initial mud at 135.00 °C (275 °F) | Adding 2% by volume of carbon black to mud |
|--------------------------------------|----------------------------------|--|-----------------------------------|--|
| Plastic viscosity, cP | 0.032 Pa·s | 0.032 Pa·s | 0.038 Pa·s | 0.023 Pa·s |
| Yield point, 4 795 Pa, (100lb/sq ft) | 7 | 5 | 10 | 3 |

References

1. Abouzar Mirzaei Paiaman and M.K. Ghassem Al-Askari, "Designing Drilling Fluid Containing Carbon Black Particles to Overcome Problems of Gachsaran Formation While Drilling", Second National Iranian Congress of Petroleum Engineering, Ahwaz, 2008.
2. Jerry J. Rayborn, Franklinton, La.; J. Phillip Dickerson, McComb, Miss. "Method of making a drilling fluid containing carbon black in a dispersed state". Sun Drilling Products Corporation, Belle Chasse, La. 1992
3. Petroleum University of Technology, "Prediction of Stuck Pipe in Iran Using Multivariate Statistical Analysis", Thesis of MSc degree, Seyed Alireza Shoraka, Ahwaz, 2001
4. Petroleum University of Technology, "Stuck Pipe Prediction Using Artificial Neural Networks", Thesis of BSc degree, Foroud Karimi, Ahwaz, 2006
5. Sugar Land Learning Center, " Stuck Pipe Prevention Self-Learning Course", December 1999
6. University of Oxford, "Physical & Theoretical Chemistry Laboratory", <http://www.pcl.ox.ac.uk/>



Authors:

Abouzar Mirzaei Paiaman, Sharif University of Technology, Iran
Mirzaei1986@gmail.com

Bandar Duraya Al-Anazi, King Abdulaziz City for Science & Technology, Saudi Arabia, Bandar.alanazi@gmail.com

Nomenclature

T: Tension forces acting on drill pipe

S: Side force

B: Apparent weight of the element in the mud.