

Pedal Surfaces of First Order Congruences

Pedal Surfaces of First Order Congruences

ABSTRACT

This paper is an overview of the pedal surfaces \mathcal{P}_n^{n+2} for first order line congruences. We describe their construction, prove their algebraic properties, derive parametric and implicit equations and visualize these new resulting surfaces with the program *Mathematica* in seven examples.

Key words: congruence of lines, pedal surface of congruence, pinch-point, singular point

MSC 2010: 51N20, 51N15, 51M15, 65D18

Nožišne plohe kongruencija prvog reda

SAŽETAK

U radu je dan pregled nožišnih ploha \mathcal{P}_n^{n+2} za kongruencije prvog reda. Opisana je njihova konstrukcija, dokazana su njihova algebarska svojstva, izvedene su parametarske i implicitne jednadžbe za opći slučaj, a za sedam primjera, pomoću programa *Mathematica*, vizualizirani su njihovi oblici.

Ključne riječi: kongruencija, nožišna ploha kongruencije, kuspidalna točka, singularna točka

1 Introduction

Congruence C is a set of lines in a three-dimensional space (projective, affine or Euclidean) depending on two parameters [3]. The line $l \in C$ is said to be a *ray* of the congruence. The *order* of an algebraic congruence is the number of its rays passing through an arbitrary point; the *class* of a congruence is the number of its rays lying in an arbitrary plane. C_n^m denotes an *m*th order *n*th class congruence. A point is a *singular point* of a congruence if ∞^1 rays pass through it. A plane is a *singular plane* of a congruence if it contains ∞^1 rays.

In Euclidean space \mathbb{E}^3 , the *pedal surface* of a congruence C_n^m with respect to a pole P is the locus of the foot points of perpendiculars from the point P to the rays of the congruence C_n^m . The order of the pedal surface of C_n^m for the pole P is $2m + n$ [11].

2 First order line congruences

According to [16, p. 64], [22, pp. 1184-1185], [19, p. 32], there are only two types of first order line congruences directed by loci of points. Their rays intersect two curves or the same curve twice.

The *first type* is the type of *n*th class congruences C_n^1 , their rays are transversals of one straight line d and one *n*th order curve c^n which cuts this straight line at $n - 1$ points. These curves are called the *directing lines* of C_n^1 . The in-

tersection points of d and c^n can be multiple points of c^n with the highest multiplicity $n - 2$ for a space curve and $n - 1$ for a plane curve. Some of these points can coincide, and there are cases when d is the tangent line of c^n , the tangent at inflection, etc. If c^n is a plane curve, it must contain an $(n - 1)$ -ple point which is the intersection point of d and the plane of c^n . All singular points of C_n^1 lie on its directing lines c^n and d , and all singular planes of C_n^1 are the planes of the pencil $[d]$ (see Fig. 1).

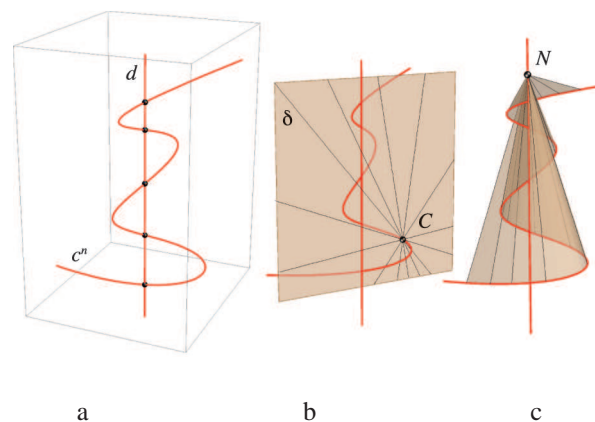

Figure 1: The directing lines of C_n^1 are shown in figure a. For a point $C \in c^n$, the rays of C_n^1 form a pencil of lines in the plane through d (figure b) and for $N \in d$ they form an *n*th degree cone with the vertex N (figure c).

The *second type* of first order line congruences consists only of 3rd class congruences and their rays are bisectors of a twisted cubic k^3 . Unlike the first type congruence C_3^1 , this type will be denoted by \mathcal{K}_3^1 .

The properties of the first order congruences (the construction of their rays, singular points and planes, focal properties, etc.) can be found in [2].

3 Pedal surfaces of C_n^1

In [1] the authors define one transformation of three-dimensional projective space where corresponding points lie on the rays of the 1st order, n th class congruence C_n^1 and are conjugate with respect to a proper quadric Ψ . This transformation, called $(n + 2)$ -degree inversion, maps a straight line to an $(n + 2)$ -order space curve, and a plane to an $(n + 2)$ -order surface which contains an n -ple straight line.

Proposition 1 *The pedal surface of the first type congruence C_n^1 with respect to a pole P is an $(n + 2)$ -order surface with n -ple straight line d containing the curve c^n and the absolute conic of \mathbb{E}^3 .*

PROOF: Orthogonality in Euclidean space \mathbb{E}^3 means conjugacy with respect to the absolute conic. The plane through a point A is orthogonal to a line l iff it is the polar plane of the point at infinity on the line l with respect to any sphere with the center A . Thus, the pedal surface of a congruence C_n^1 with respect to a pole P is the image of the plane at infinity given by the $(n + 2)$ -degree inversion with respect to C_n^1 and any sphere with the center P . According to [1], it is an $(n + 2)$ -order surface with an n -ple straight line d containing the curve c^n and the absolute conic of \mathbb{E}^3 . \square

In the following, \mathcal{P}_n^{n+2} denotes the pedal surface of C_n^1 .

Proposition 2 *If the directing line d lies in the plane at infinity, the pedal surface \mathcal{P}_n^{n+2} splits into an $(n + 1)$ -order surface with the $(n - 1)$ -ple line d and the plane at infinity.*

PROOF: This proposition follows from the property of the $(n + 2)$ -degree inversion which is given in theorem 4 [1] (see examples 4.5.). \square

Proposition 3 *If the directing curve c^n lies in the plane at infinity, the pedal surface \mathcal{P}_n^{n+2} splits into an $(n + 1)$ -degree ruled surface with the n -ple line d and the plane at infinity.*

PROOF: This proposition follows from the property of the $(n + 2)$ -degree inversion which is given in theorem 3 [1] (see examples 4.6.). \square

3.1 Construction of the pedal surface \mathcal{P}_n^{n+2}

It is clear that any plane through the n -ple line of an $(n + 2)$ -order surface intersects this surface at its n -ple line and one conic. If the surface contains the absolute conic, this intersection conic is a circle.

In any plane δ through the directing straight line d , the rays of C_n^1 form the pencil of lines (C) , where the point $C \notin d$ is the intersection of the plane δ and the directing curve c^n . If a pole P is in the general position with respect to the directing lines of the congruence C_n^1 , the feet of perpendiculars from P to the rays of the pencil (C) form a circle c with the diameter $\overline{CP'}$, where P' is the orthogonal projection of P onto δ . For a given pole P , the path of the point P' is the circle k lying in the plane through P perpendicular to d . The diameter of k is $\overline{PP_d}$, where P_d is the orthogonal projection of P onto d .

Thus, we can regard the pedal surface \mathcal{P}_n^{n+2} as the system of circles in the planes through the n -ple line d with the end points of diameters on the curve c^n and the circle k (see Fig. 2). The diameters of the circles c lie on the rulings of one $(n + 2)$ -degree ruled surface with the directing lines c^n , d and k [14, p. 186], [16, p. 90].

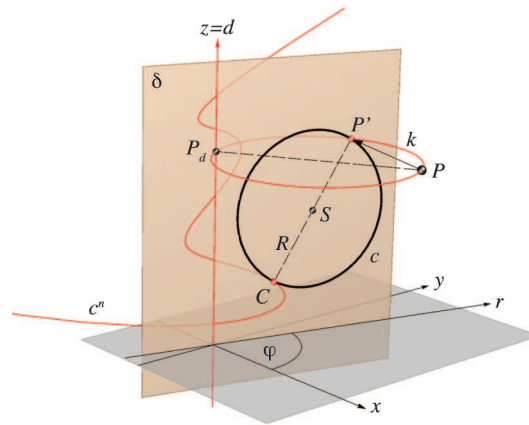

Figure 2: One system of the curves on \mathcal{P}_n^{n+2} can be constructed as circles in the planes through d with the end points of the diameters on c^n and k .

3.2 Singularities of \mathcal{P}_n^{n+2}

The highest singularity which a proper \mathcal{P}_n^{n+2} can possess is an $(n + 1)$ -ple point. If such a point exists, it must lie on its n -ple line. Namely, if \mathcal{P}_n^{n+2} had an $(n + 1)$ -ple point A out of d , every line through A which cuts d would cut \mathcal{P}_n^{n+2} at $2n + 1$ points. This is possible only in the case if this line lies entirely on \mathcal{P}_n^{n+2} , but then the surface must break up into the plane through A and d and one ruled surface of the degree $n + 1$.

Proposition 4 An $(n + 1)$ -ple point exists on \mathcal{P}_n^{n+2} iff a pole P lies on d . The highest number of such points on \mathcal{P}_n^{n+2} is two only if c^n lies in the plane perpendicular to d .

PROOF: If a pole P lies on d , then every circle c passing through P , and it is the $(n + 1)$ -ple point of \mathcal{P}_n^{n+2} because every straight line through P (except d) intersects \mathcal{P}_n^{n+2} at P and only one additional point on c . Inversely, if $N^{n+1} \in d$ is an $(n + 1)$ -ple point, every circle c must pass through it. Namely, if some circle c did not pass through N^{n+1} , every line in the plane of c passing through N^{n+1} would cut \mathcal{P}_n^{n+2} at $n + 3$ points, which is impossible. It is possible only if $N^{n+1} = P$, because the circle k must break up into a pair of isotropic lines with the double point P . If there exists one more $(n + 1)$ -ple point O on d , it must lie on c^n because all circles c pass through P and O . It is possible only if c^n is a planar curve with an $(n - 1)$ -ple point O . It is elementary that in such a case c^n lies in the plane perpendicular to d (Thales' theorem). \square

Any other point $N \in d$ is an n -planar point – the tangent cone at N splits into n planes through d . Namely, n circles c pass through $N \in d$ and the planes of these circles form the splitting tangent cone \mathcal{ST}_N^n of \mathcal{P}_n^{n+2} at N . If some of these tangent planes coincide, the touching point is the pinch-point of \mathcal{P}_n^{n+2} . The tangent planes at an n -planar point can be real or imaginary. Depending on the number of real and imaginary tangent planes, as well as the number of coinciding planes, we distinguish different types of n -planar points. To calculate the number of these types we use the partition function¹ $p : \mathbb{N} \cup \{0\} \rightarrow \mathbb{N}$ [21].

Proposition 5 The number of types of the splitting tangent cones \mathcal{ST}^n at n -planar points is

$$\sum_{s=0}^{s=\lfloor \frac{n}{2} \rfloor} p(s) \cdot p(n - 2s).$$

PROOF: Any cone \mathcal{ST}^n consists of s ($0 \leq s \leq \lfloor \frac{n}{2} \rfloor$) pairs of imaginary planes and $n - 2s$ real planes. The number of different multiplicities of these planes equals the sum of the corresponding partitions. \square

Proposition 6 The number of types of pinch-points on \mathcal{P}_n^{n+2} is

$$-1 - \lfloor \frac{n}{2} \rfloor + \sum_{s=0}^{s=\lfloor \frac{n}{2} \rfloor} p(s) \cdot p(n - 2s).$$

¹A partition of a positive integer n is a way of writing n as a sum of positive integers. The number of partitions of n is given by the partition function $p(n)$ where $p(0) = 1$ by convention. The partition function is implemented in *Mathematica* as `PartitionP[n]` or `NumberOfPartitions[n]` in the *Mathematica* package `Combinatorica`'.

PROOF: The number of possibilities that no planes of \mathcal{ST}^n coincide is $1 + \lfloor \frac{n}{2} \rfloor$. In all other cases, at least two tangent planes coincide and the touching point is the pinch-point of \mathcal{P}_n^{n+2} . \square

Proposition 7 On the pedal surface \mathcal{P}_n^{n+2} exist $4(n - 1)$ pinch-points.

PROOF: Every plane δ of the pencil $[d]$ cuts \mathcal{P}_n^{n+2} at the n -ple line d and one circle c . The intersection points N_1, N_2 of d and c are the touching points of δ and \mathcal{P}_n^{n+2} . But, through each of the points N_1 and N_2 other $n - 1$ tangent planes pass. The correspondence between the planes of the pencil $[d]$, where corresponding planes have the same touching point, is an involution of the order $2(n - 1)$. This involution has $4(n - 1)$ double elements [13, p. 48] which are the coinciding tangent planes through the points on the n -ple line, and their touching points are the pinch-points of \mathcal{P}_n^{n+2} [18, p. 317]. These points can be real or imaginary. \square

Except for the points on the n -ple line d , the highest singularity which \mathcal{P}_n^{n+2} can possess is a double point.

Proposition 8 The maximal number of real double points on \mathcal{P}_n^{n+2} is:

- n , if c^n is a space curve,
- $n + 1$, if c^n is a planar curve.

PROOF: If D is the double point of \mathcal{P}_n^{n+2} , it is a double point for every section of \mathcal{P}_n^{n+2} through D . Thus, the circle c in the plane through D and the line d splits into a pair of isotropic lines through D . This is the case when the end points of the diameter \overline{CP} coincide, i.e. circle k intersects the curve c^n at the point D . Therefore, if c^n is a space curve, \mathcal{P}_n^{n+2} can possess at most n double points in the plane of the circle k . But if c^n is a plane curve in the plane of k , then c^n and k can possess $n + 1$ intersection points which do not lie on d . \square

3.3 Parametric equations of \mathcal{P}_n^{n+2}

Let the directing lines of C_n^1 be the axis z and the curve c^n given by the following parametrization:

$$\mathbf{r}_{c^n}(\varphi) = (x_{c^n}(\varphi), y_{c^n}(\varphi), z_{c^n}(\varphi)), \quad x_{c^n}, y_{c^n}, z_{c^n} : [0, \pi) \rightarrow \mathbb{R}. \tag{1}$$

Let (p_x, p_y, p_z) be the coordinates of the pole P .

Let (r, z) , where $|r| = \sqrt{x^2 + y^2}$, be the coordinates in the plane $\delta(\varphi)$ given by the equation $y = x \tan \varphi$ if $\varphi \in [0, \pi)$, $\varphi \neq \pi/2$, and $x = 0$ if $\varphi = \pi/2$ (see Fig. 2).

The coordinates of the points $C, P' \in \delta(\varphi)$ are

$$\begin{aligned} r_C(\varphi) &= \sqrt{x_{c^n}(\varphi)^2 + y_{c^n}(\varphi)^2}, & z_C(\varphi) &= z_{c^n}(\varphi) \\ r_{P'}(\varphi) &= p_x \cos \varphi + p_y \sin \varphi, & z_{P'}(\varphi) &= p_z. \end{aligned} \quad (2)$$

$R(\varphi)$ is the radius and $S(r_S(\varphi), z_S(\varphi))$ is the center of the circle c in the plane $\delta(\varphi)$:

$$\begin{aligned} R(\varphi) &= \frac{\sqrt{(r_C(\varphi) - r_{P'}(\varphi))^2 + (z_C(\varphi) - p_z)^2}}{2} \\ r_S(\varphi) &= \frac{r_C(\varphi) + r_{P'}(\varphi)}{2} \\ z_S(\varphi) &= \frac{z_C(\varphi) + p_z}{2} \end{aligned} \quad (3)$$

Since the parametric equations of the circle c in the plane $\delta(\varphi)$ are

$$\begin{aligned} r(\theta) &= R(\varphi) \sin \theta + r_S(\varphi) \\ z(\theta) &= R(\varphi) \cos \theta + z_S(\varphi), \quad \theta \in [0, 2\pi), \end{aligned} \quad (4)$$

the parametric equations of the surface \mathcal{P}_n^{n+2} are the following:

$$\begin{aligned} x(\theta, \varphi) &= \cos \varphi (R(\varphi) \sin \theta + r_S(\varphi)) \\ y(\theta, \varphi) &= \sin \varphi (R(\varphi) \sin \theta + r_S(\varphi)) \\ z(\theta, \varphi) &= R(\varphi) \cos \theta + z_S(\varphi), \end{aligned} \quad (5)$$

$\varphi \in [0, \pi), \theta \in [0, 2\pi).$

3.4 Implicit equation of \mathcal{P}_n^{n+2}

According to [1], the plane at infinity cuts \mathcal{P}_n^{n+2} at the absolute conic and n rays of C_n^1 . These rays pass through the point at infinity of the directing line d and can be real or imaginary. Therefore, the polynomial of the highest degree in the implicit equation of \mathcal{P}_n^{n+2} can be written in the form $(x^2 + y^2 + z^2)H^n(x, y)$, where $H^n(x, y)$ is the homogeneous polynomial of degree n .

Theorem 1 *If an n th order surface in \mathbb{E}^3 which passes through the origin is given by the equation*

$$F(x, y, z) = f_m(x, y, z) + f_{m+1}(x, y, z) + \dots + f_n(x, y, z) = 0,$$

where $f_k(x, y, z)$ ($1 \leq k \leq n$) are homogeneous polynomials of degree k , then the tangent cone at the origin is given by the equation $f_m(x, y, z) = 0$.

The proof of this theorem is given in [9, p. 251].

Thus, since the axis z is the n -ple line of \mathcal{P}_n^{n+2} , the implicit equation of \mathcal{P}_n^{n+2} takes the following form:

$$(x^2 + y^2 + z^2)H_1^n(x, y) + H^{n+1}(x, y, z) + H_2^n(x, y) = 0, \quad (6)$$

where H_j^i are homogeneous polynomials of degree i .

From eq. (4), by using the standard coordinate transformation formulas for Cartesian and cylindrical coordinates, it is possible to determine the polynomials H_j^i for every \mathcal{P}_n^{n+2} .

4 Examples of \mathcal{P}_n^{n+2}

4.1 \mathcal{P}_1^3 – pedal surfaces of linear congruences

The pedal surfaces of linear congruences C_1^1 are cubics which contain the absolute conic. It was shown in [11] that in the general case if C_1^1 is a hyperbolic linear congruence, seven real straight lines exist on the pedal surface \mathcal{P}_1^3 ; if C_1^1 is elliptic, three real straight lines exist on \mathcal{P}_1^3 ; if C_1^1 is parabolic, then \mathcal{P}_1^3 contains one double point and five real straight lines and two of them are counted twice. Figure 3 shows three types of parabolic cyclides obtained as the pedal surfaces of the hyperbolic linear congruence.

4.2 \mathcal{P}_2^4 – pedal surfaces of 1st order 2nd class congruences

A complete classification of the pedal surfaces of C_2^1 is given in [6]. If there are no directing lines of C_2^1 in the plane at infinity, the pedal surface \mathcal{P}_2^4 is a quartic with a double straight line. These surfaces are classified in five types depending on the number of real straight lines on them. According to propositions 4 and 8, there are at most two triple points (see Fig. 4) and at most three real double points (see Fig. 5c) on the pedal surfaces \mathcal{P}_2^4 .

The points on the double line d are bi-planar points – tangent cones split into two planes through d . These points can be isolated (two tangent planes are imaginary), binodal (the tangent planes are real and different) or pinch-points (coinciding tangent planes). The pinch-points of \mathcal{P}_2^4 separate the intervals with isolated and binodal points on d and there are at most four real pinch-points on d (see Fig. 5a).

If one directing line d or c^2 lies in the plane at infinity, the pedal surface \mathcal{P}_2^4 splits into the plane at infinity and into a cubic surface.

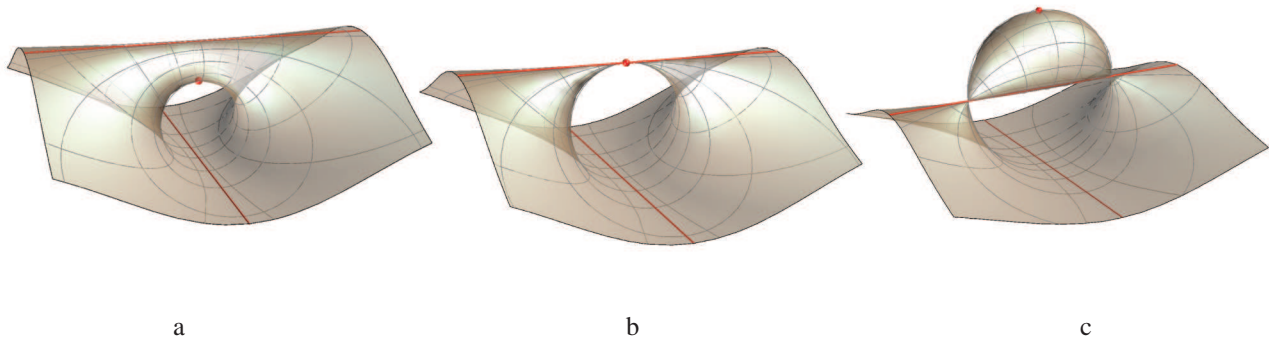

Figure 3: The directing orthogonal lines of C_1^1 are the axis z , placed in the horizontal plane, and the line parallel to the axis y in the plane $x = 1$. For three different positions of the pole P on the axis x ($x_P = \frac{1}{2}, 1, 2$), the pedal surface is the ring, spindle and horn parabolic cyclide [4, pp. 371-373] in the case a, b and c, respectively.

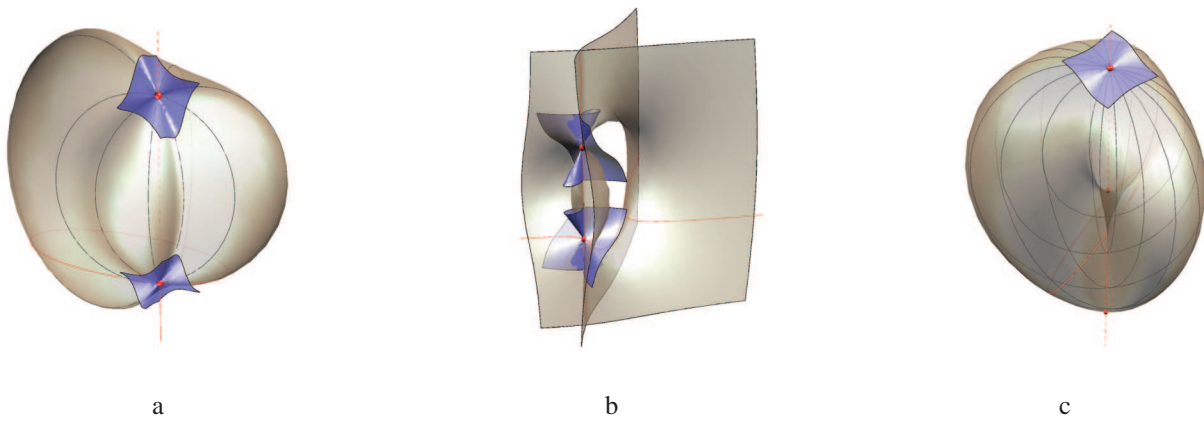

Figure 4: \mathcal{P}_2^4 with triple points and 3rd order tangent cones. The directing elements are: figure a – $c^2(x^2 + 4y^2 - 2x + 4y = 0, z = 0)$, $P(0, 0, 2)$; figure b – $c^2(x^2 - y^2 - 2x = 0, z = 0)$, $P(0, 0, 2)$; figure c – $c^2(x^2 + y^2 + 2x + 4y = 0, x - y + z = 0)$, $P(0, 0, 8)$. Except the triple points, all points on the double line are isolated in the case a, and binodal in the case b. In the case c, two pinch-points separate the segments with isolated and binodal points on the double line.

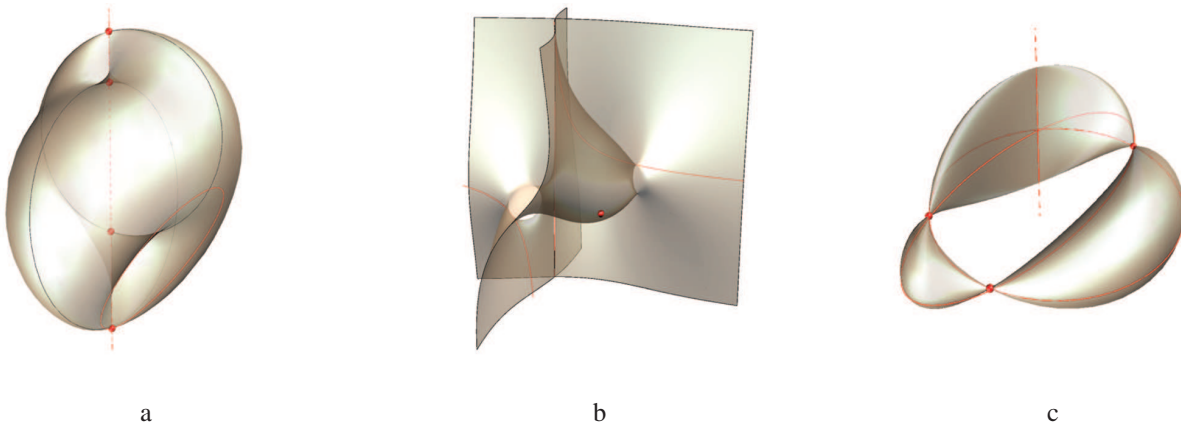

Figure 5: \mathcal{P}_2^4 with four real pinch-points is shown in figure a. The directing elements are $c^2(x^2 + 0.5y^2 + x + y = 0, x + y + z = 0)$ and $P(1, 1, 5)$. The pedal surface in figure b has no real pinch-points and its directing elements are $c^2(yz = 1, x = 1)$ and $P(2.5, 2, -0.3)$. The directing elements for \mathcal{P}_2^4 in figure c are $c^2(x^2 + 6y^2 - x - 4y = 0, z = 0)$ and $P(1, 1, 0)$. Three conical points of this surface are the intersection points (different from the origin) of c^2 and the circle k .

4.3 Special \mathcal{P}_4^6 directed by Viviani’s curve

Special sextics with a quadruple line \mathcal{P}_4^6 are elaborated in detail in [5]. They are obtained as the pedal surfaces of one special first order fourth class congruence \mathcal{C}_4^1 directed by the axis z and Viviani’s curve – the intersection of the sphere $(x + \sqrt{2})^2 + y^2 + (z + \sqrt{2})^2 = 4$ and the cylinder $(x + z + \sqrt{2})^2 + 2y^2 = 2$ (see Fig. 6). Viviani’s curve is given by the following parametrization:

$$\mathbf{r}(\varphi) = 4\sqrt{2} \frac{1 + 3\cos 2\varphi}{(3 + \cos 2\varphi)^2} \left(-2(\cos \varphi)^2, -\sin 2\varphi, (\sin \varphi)^2 \right),$$

$$\varphi \in [0, \pi]. \tag{7}$$

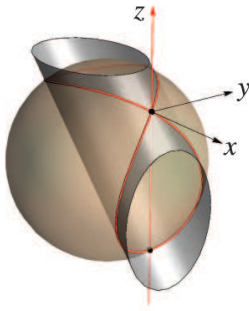

Figure 6: The origin is the double point of Viviani’s curve c^4 (the intersection of a sphere and cylinder) and the axis z cuts c^4 at one more regular point $z_0 = -2\sqrt{2}$.

The highest singularity which \mathcal{P}_4^6 can possess is a quintuple point. According to the type of its 5th degree tangent cone,

we distinguish six types of quintuple points on \mathcal{P}_4^6 [5]. Three of them are shown in Figure 7. The points on the axis z are quadri-planar points of \mathcal{P}_4^6 , their tangent cones split into four planes through z . These tangent planes can be real and different, real and coinciding or imaginary. According to proposition 5, we distinguish nine types of quadri-planar points: *type 1* – four real and different tangent planes; *type 2* – two real and different planes and a pair of imaginary planes; *type 3* – two different pairs of imaginary planes; *type 4* – one double plane and two different single real planes; *type 5* – one double plane and a pair of imaginary planes; *type 6* – a pair of double real planes; *type 7* – a double pair of imaginary planes; *type 8* – one triple plane and one single plane; *type 9* – one quadruple plane. On the axis z the intervals with quadri-planar points of types 1–3 are bounded by the points of the types 4–9 which are the pinch-points of \mathcal{P}_4^6 . Since four rays of \mathcal{C}_4^1 in the plane at infinity are given by the equation $(2x^2 + y^2)^2 = 0$, the point at infinity on the axis z is the pinch-point of type 7. The type of a quadri-planar point depends on the factorization of the homogeneous 4th degree polynomial in x and y which represents its cone. Based on the conditions given in [20], we made a program in *Mathematica 6* (available on-line: www.grad.hr/sgorjanc/pinch_points.nb) which calculates the coordinates z_0 of the pinch-points of \mathcal{P}_4^6 for every choice of pole P . According to proposition 7, the highest number of real pinch-points of \mathcal{P}_4^6 is twelve. Three examples are shown in Fig. 8.

The following is shown in [5]: iff a pole P lies on the part of one parabola, \mathcal{P}_4^6 has two real conical points; iff P lies on one 5th degree ruled surface, \mathcal{P}_4^6 has at least one real conical point.

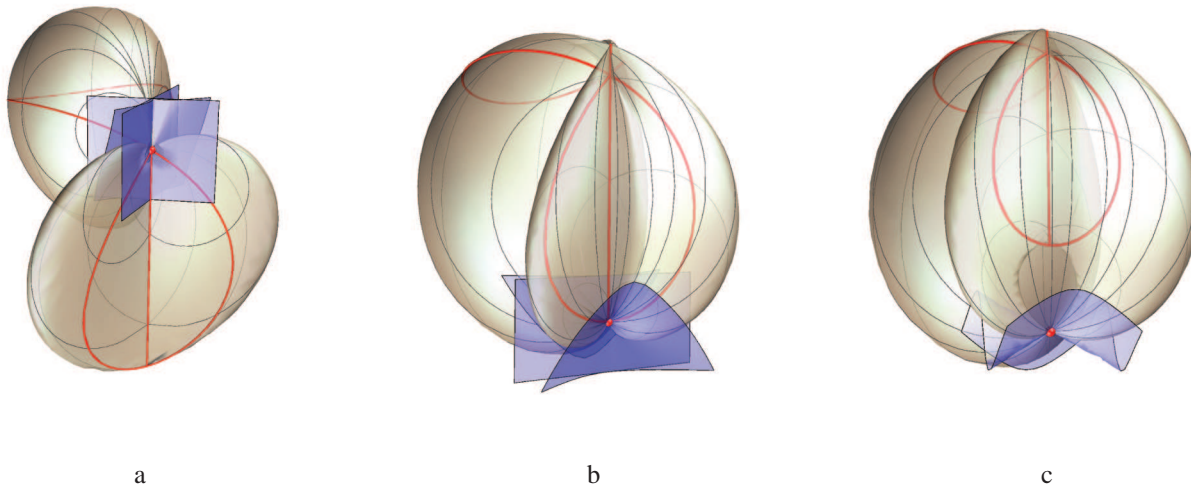

Figure 7: If $P = O$, the tangent cone at P splits into two planes and one 3rd degree cone (a). If $P = (0, 0, -2\sqrt{2})$, the tangent cone at P splits into a 4th degree cone and one plane (b). For all other positions of a pole $P \in z$, the tangent cones at P are proper 5th degree cones with a quadruple line z . Such a cone with an isolated quadruple line is shown in figure c.

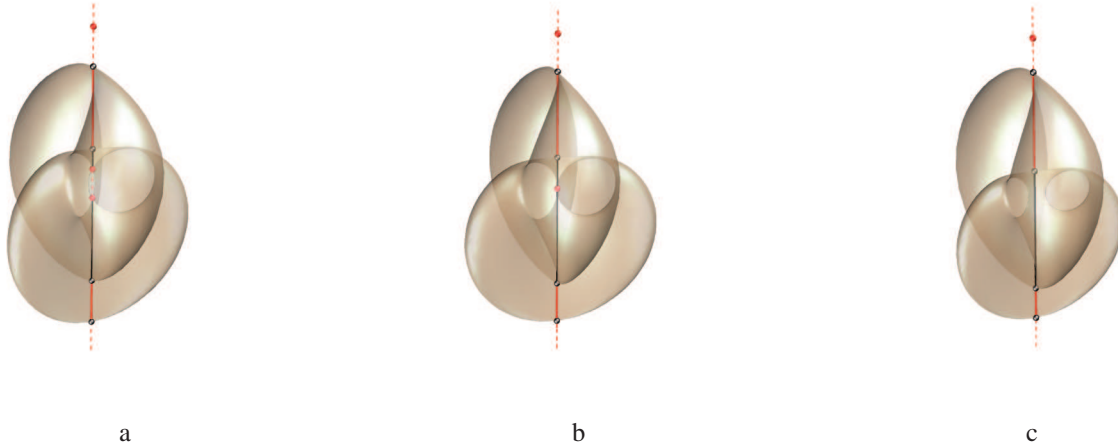

Figure 8: The surfaces \mathcal{P}_4^6 with 12, 10 and 8 real pinch-points are shown in figures a, b and c, respectively. The pinch-points counted twice (types 6 and 7) are indicated by red color. Other pinch-points (types 4 and 5) are black. Besides the highlighted pinch-points, every surface \mathcal{P}_4^6 has a pinch-point of type 7 at infinity. The segments on the axis z contain quadruple points of type 1 (black), type 2 (red) and type 3 (dashed red).

4.4 Special \mathcal{P}_{2k}^{2k+2} directed by roses

Roses or rhodonea are curves which can be expressed by the following polar equations:

$$r(\varphi) = \cos n\varphi \quad \text{or} \quad r(\varphi) = \sin n\varphi, \quad n \in \mathbb{R}. \tag{8}$$

If $n = 2k - 1, k \in \mathbb{N}$, the curves close at a polar angle π and have n petals. They are algebraic curves of the order $n + 1$, with only one singular point – an n -ple point in the origin [12, pp. 358-369]. According to the multiple-angle formula $\cos n\varphi = \sum_{i=0}^{\lfloor \frac{n}{2} \rfloor} (-1)^i \binom{n}{2i} (\cos \varphi)^{n-2i} (\sin \varphi)^{2i}$ and the standard coordinate transformation formulas, their implicit equation is

$$(x^2 + y^2)^k - \tau^{2k-1} = 0, \quad \text{where} \tag{9}$$

$$\tau^{2k-1} = \sum_{i=0}^k (-1)^i \binom{2k-1}{2i} x^{2k-1-2i} y^{2i}. \tag{10}$$

It is clear ([9, p. 251], [17, p. 27]) that $2k - 1$ tangent lines at the origin are given by

$$\tau^{2k-1} = 0. \tag{11}$$

Some examples are shown in Fig. 9.

Let the axis z and the curve c^{2k} given by equations

$$(x^2 + y^2)^k - \tau^{2k-1} = 0, \quad ax + by + z = 0, \tag{12}$$

be the directing lines of a congruence C_{2k}^1 . The curve c^{2k} is the intersection of one $2k$ -order cylinder and a plane through the origin (see Fig. 10a). The singular points of C_{2k}^1 lie on its directing lines c^{2k} and z (see Fig. 10b and Fig. 10c). The rays of C_{2k}^1 through the origin O form the pencil of lines (O) in the plane $ax + by + z = 0$, and the other lines through O are not regarded as the rays of C_{2k}^1 . The pedal surface \mathcal{P}_{2k}^{2k+2} of C_{2k}^1 with respect to a pole P is a $(2k + 2)$ -order surface with $2k$ -ple line z (see Fig. 10d).

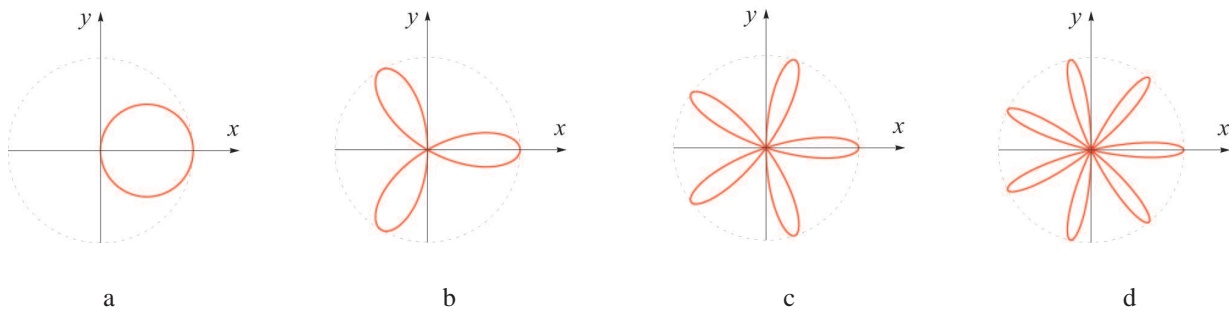

Figure 9: The curves $r(\varphi) = \cos n\varphi$ for n equal to 1, 3, 5 and 7 are shown in figures a, b, c and d, respectively.

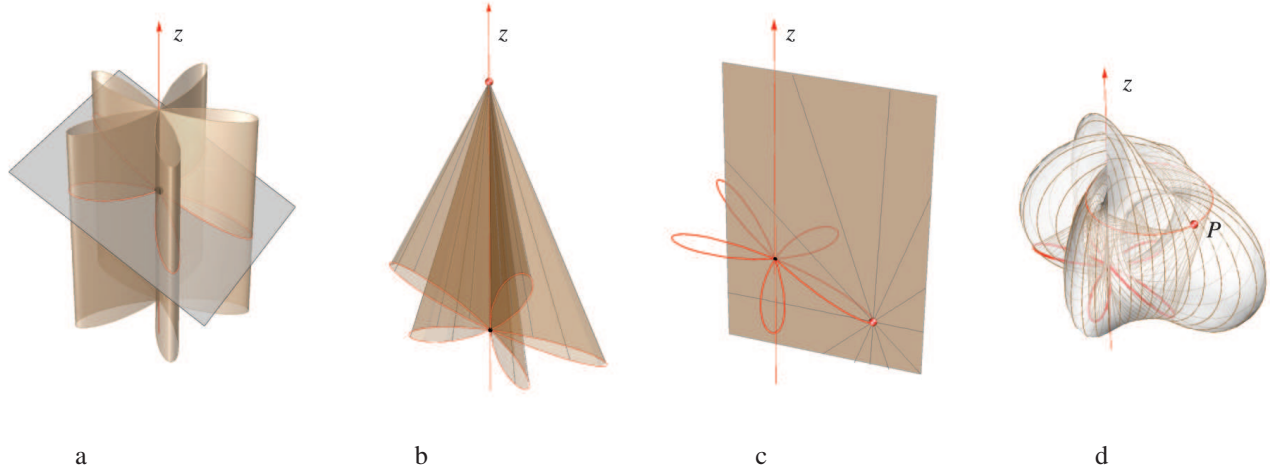

Figure 10: c^{2k} is the intersection of one $2k$ -degree cylinder with a $(2k - 1)$ -ple line z and a plane through the origin (a). The rays of C_{2k}^1 through a point on z form a $2k$ -degree cone with a $(2k - 1)$ -ple line z (b). The rays of C_{2k}^1 through a point $C \in c^{2k}$ form the pencil of lines (C) in the plane through z and C (c). The pedal surface \mathcal{P}_{2k}^{2k+2} is a system of circles in the planes through z , with the end points of its diameters on c^{2k} and k . These diameters lie on the rulings of one $(2k + 2)$ -degree ruled surface (d).

In every plane through z , the coordinates of $C \in c^{2k}$ are given by

$$(r_C(\varphi), z_C(\varphi)) = \cos n\varphi(1, -a \cos \varphi - b \sin \varphi). \quad (13)$$

From (13) and eqs. (2) – (5), we obtain the parametric equations of \mathcal{P}_{2k}^{2k+2} which enable them to be visualized using the program *Mathematica*. Some examples are shown in Fig. 11.

Since every plane through the axis z cuts \mathcal{P}_{2k}^{2k+2} at the circle c and the $2k$ -ple line z , the equation of \mathcal{P}_{2k}^{2k+2} in the cylindrical coordinates (r, φ, z) is

$$r^{2k} \cdot ((r - r_S(\varphi))^2 + (z - z_S(\varphi))^2 - R^2(\varphi)) = 0. \quad (14)$$

From (14), by using eqs. (13), (2), (3) and the standard coordinate transformation formulas, we obtain the following implicit equation of \mathcal{P}_{2k}^{2k+2} :

$$(x^2 + y^2 + z^2)(x^2 + y^2)^k + H^{2k+1}(x, y, z) + H^{2k}(x, y) = 0, \quad (15)$$

where

$$\begin{aligned} H^{2k+1}(x, y, z) &= -(p_x x + p_y y + p_z z)(x^2 + y^2)^k \\ &\quad - (x^2 + y^2 - axz - byz)\tau^{2k-1} \\ H^{2k}(x, y) &= (p_x x + p_y y - ap_z x - bp_z y)\tau^{2k-1}. \end{aligned} \quad (16)$$

The plane at infinity cuts \mathcal{P}_{2k}^{2k+2} at the absolute conic and the pair of isotropic lines counted k times. These isotropic lines are the rays of C_{2k}^1 and also the rulings of the rose-cylinder given by the first equation in (12). Thus, the point at infinity on the axis z is the pinch-point of \mathcal{P}_{2k}^{2k+2} .

If we translate the origin into $Z_0(0, 0, z_0)$, then (from eq. (15) and according to theorem 1) we obtain the following equation of the splitting tangent cone at Z_0 :

$$(z_0^2 - p_z z_0)(x^2 + y^2)^k + (x(p_x + az_0 - ap_z) + y(p_y + bz_0 - bp_z))\tau^{2k-1} = 0. \quad (17)$$

The surface \mathcal{P}_{2k}^{2k+2} has a $(2k + 1)$ -ple point iff P lies on the axis z . In this case, all coefficients in eq. (17) are equal to zero, and the tangent cone at P , in the coordinate system with the origin P , is given by the following equation:

$$p_z z(x^2 + y^2)^k - (x^2 + y^2 - axz - byz)\tau^{2k-1} = 0. \quad (18)$$

If $P = O$, the tangent cone at P splits into one 2nd degree cone and $(2k - 1)$ planes through the axis z

$$(x^2 + y^2 - axz - byz)\tau^{2k-1} = 0. \quad (19)$$

Three examples are shown in Fig 12.

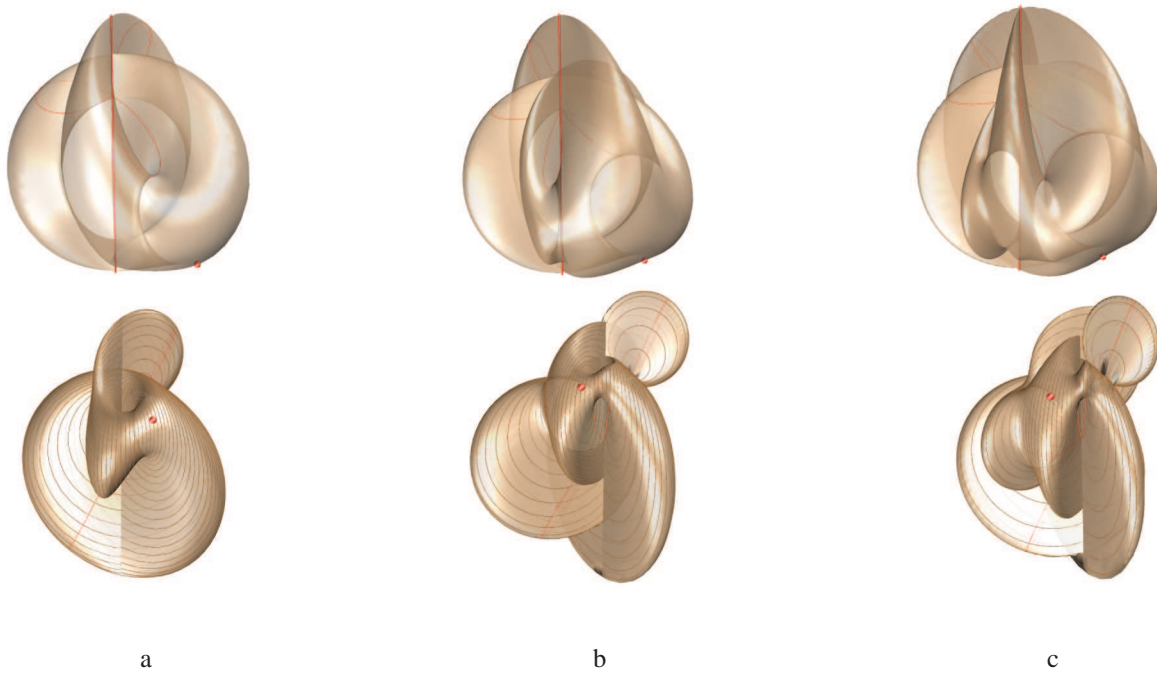

Figure 11: The pedal surfaces \mathcal{P}_{2k}^{2k+2} for the poles $P(-1, 1, -2)$, $P(-1, 1, 1)$ and $k = 2, 3, 4$ are shown in figures a, b and c, respectively.

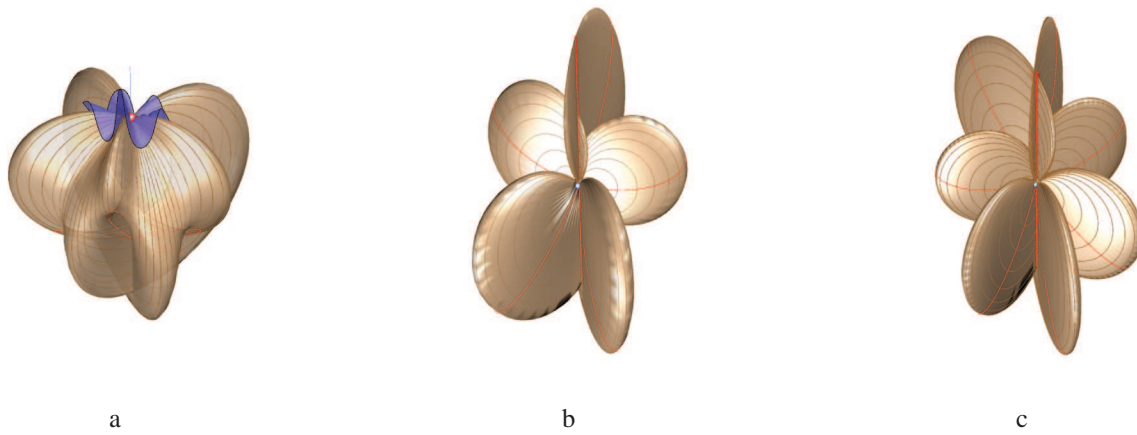

Figure 12: The surface \mathcal{P}_6^8 , directed by the 5-petalled curve in the plane $x + y + z = 0$ and the pole $P(0, 0, 2)$, and its 7th degree tangent cone at P , are shown in figure a. The pedal surfaces, directed by the 5-petalled and 7-petalled curves in the plane $x + y + z = 0$ and $P = O$, are shown in figures b and c, respectively.

According to proposition 8, \mathcal{P}_{2k}^{2k+2} possesses the highest number of real double points if the directing curve c^{2k} and the circle k lie in the same plane. It is the case that $a = b = p_z = 0$ when c^{2k} and k have $4k$ intersection points. But $2k - 1$ points coincide with O , two points are the absolute points of the plane $z = 0$, thus only $2k - 1$ intersection points can lie besides the axis z and be real. Since $2k - 1$

is an odd number, at least one real double point exists on \mathcal{P}_{2k}^{2k+2} if $a = b = p_z = 0$.

The pedal surfaces directed by the roses in the plane $z = 0$ are elaborated in detail in [7]. Some examples are shown in Fig. 13.

In this case ($a = b = 0$), if a pole P lies on the axis z , the

equation (15) takes the form

$$(x^2 + y^2)P^{2k}(x, y, z) = 0, \tag{20}$$

where

$$P^{2k}(x, y, z) = (x^2 + y^2)^{k-1}(x^2 + y^2 + z^2 - p_z z) - \tau^{2k-1}. \tag{21}$$

Thus, the pedal surface splits into a pair of isotropic planes through the axis z and one $2k$ -order surface given by $P^{2k}(x, y, z) = 0$. The line z is a $(2k - 2)$ -ple line of these surfaces with two $(2k - 1)$ -ple points, the origin O and the pole P (see Fig. 14).

Especially, if $P = O$, the tangent cone at P splits into $2k - 1$ planes given by equation $\tau^{2k-1} = 0$ (see Fig. 15).

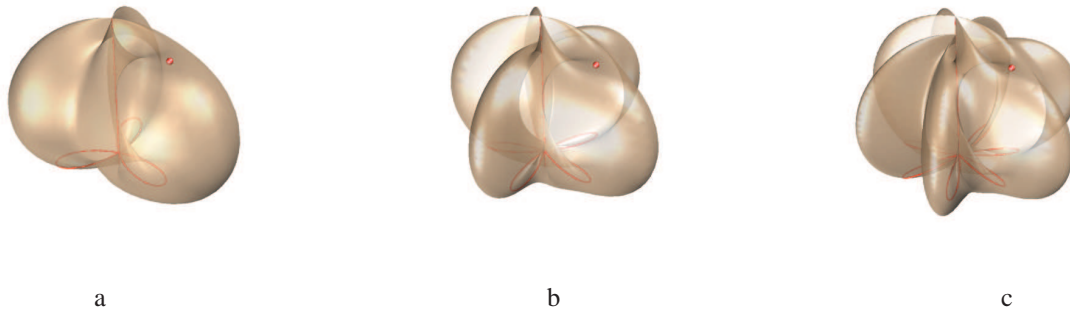

Figure 13: The pedal surfaces for the pole $P(1,0,2)$ and 3, 5 and 7-petalled roses in the plane $z = 0$ are shown in figures a, b and c, respectively.

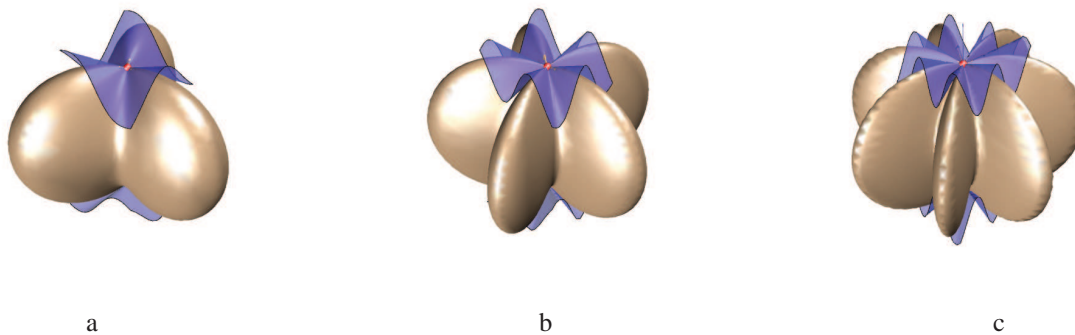

Figure 14: The pedal surfaces for the pole $P(0,0,2)$ and 3, 5 and 7-petalled roses in the plane $z = 0$ with 3, 5 and 7-degree tangent cones at P and O are shown in figures a, b and c, respectively.

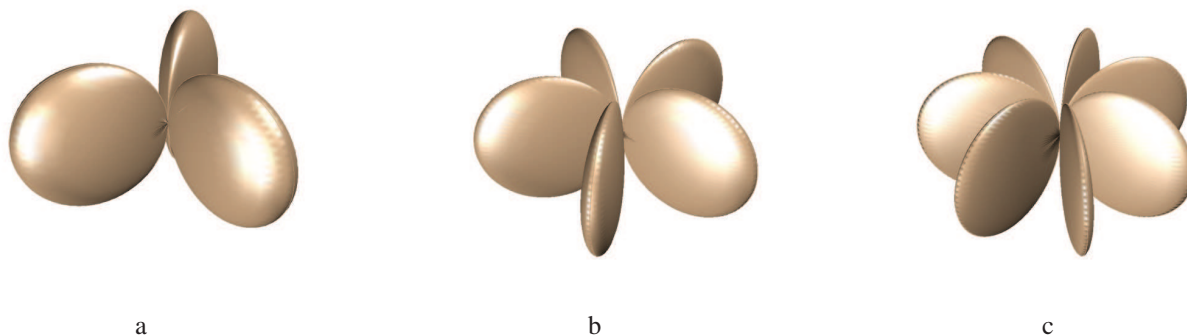

Figure 15: The pedal surfaces for the pole $P = O$ and 3, 5 and 7-petalled roses in the plane $z = 0$ are shown in figures a, b and c, respectively.

4.5 \mathcal{P}_n^{n+2} of $C_n^1(c^n, d)$ with d at infinity

If the directing line d lies in the plane at infinity (α^∞), then α^∞ is the singular plane of $C_n^1(c^n, d^\infty)$. Thus, its image given by the $(n + 2)$ -degree inversion with respect to $C_n^1(c^n, d^\infty)$ and any sphere with the center P splits into α^∞ and the image \mathcal{D}_{n-1}^{n+1} of the singular line d^∞ which is an $(n + 1)$ -order surface with the $(n - 1)$ -ple line d^∞ (see theorem 4 [1]). In this case the circle k splits into a line through P perpendicular to the pencil of planes $[d^\infty]$ and one line at infinity. The planes through d^∞ cut \mathcal{D}_{n-1}^{n+1} into the circles with the end points of diameters on k and c^n . Three examples are shown in Fig. 16.

4.6 \mathcal{P}_n^{n+2} of $C_n^1(c^n, d)$ with c^n at infinity

If the directing curve c^n lies in the plane α^∞ , the intersection point $D^\infty = \alpha^\infty \cap d$ must be the $(n - 1)$ -ple point of $c^{n\infty}$. In this case α^∞ is the singular plane of $C_n^1(c^{n\infty}, d)$ and its image given by the $(n + 2)$ -degree inversion with respect to $C_n^1(c^{n\infty}, d)$ and any sphere with the center P splits into α^∞ and the image \mathcal{R}_n^{n+1} of $c^{n\infty}$ which is one $(n + 1)$ -degree ruled surface with the n -ple line d (see theorem 3 [1]). In the plane $\delta \in [d]$ the ruling of \mathcal{R}_n^{n+1} is perpendicular to the rays of C_n^1 and passes through P' , i. e. the circle c splits into this ruling and the line at infinity. Three examples are shown in Fig. 17.

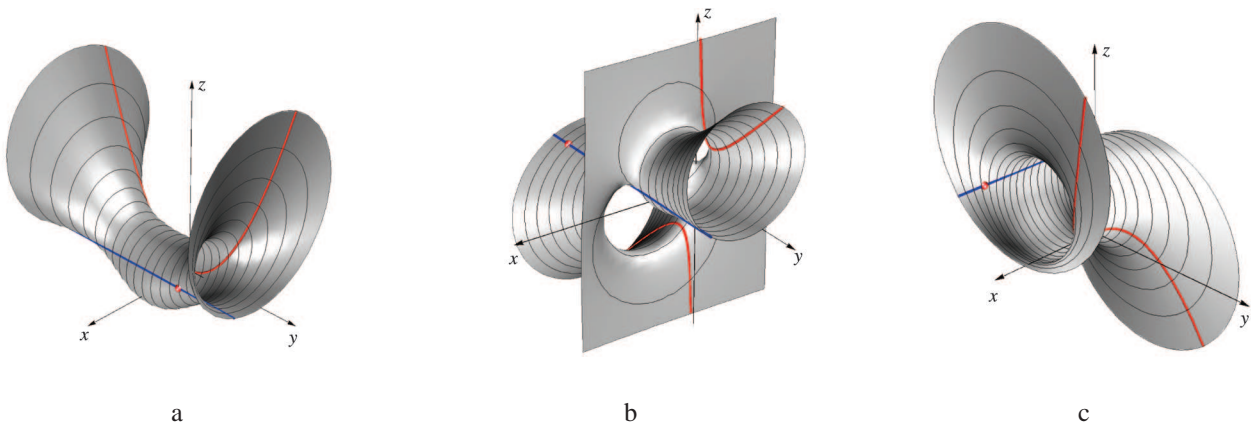

Figure 16: a – \mathcal{D}_1^3 defined by d^∞ in the plane $y = 0$, c^2 given by equations $x = 0$ and $z = \frac{y^2}{2}$ and $P(2, 1.5, 1)$.
 b – \mathcal{D}_1^3 defined by d^∞ in the plane $y = 0$, c^2 given by equations $x = 0$ and $y^2 - yz + 1 = 0$ and $P(3, -4, 1)$.
 c – \mathcal{D}_2^4 defined by d^∞ in the plane $x = 0$, c^3 given by equations $y = \frac{x^2}{5}$ and $z = \frac{x^3}{10}$ and $P(3, -4, 2)$.

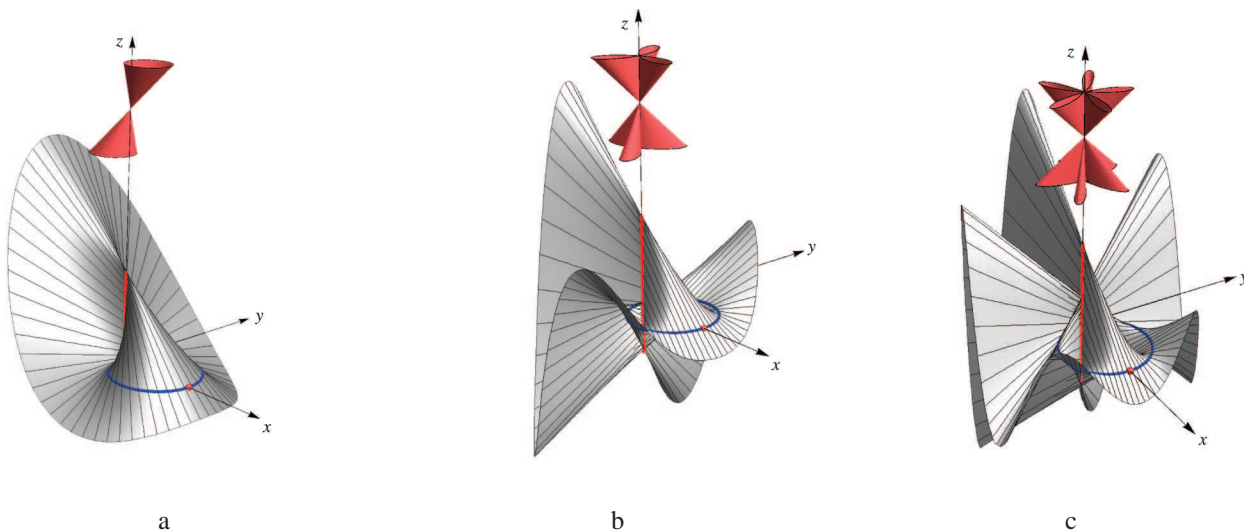

Figure 17: The pedal ruled surfaces for the pole $P(2, 0, 0)$, axis z and 1, 3 and 5-petalled roses in the plane at infinity are shown in figures a, b and c, respectively. These directing roses are the curves at infinity of the highlighted red cones.

5 Pedal surfaces of \mathcal{K}_3^1

5.1 Congruence \mathcal{K}_3^1

Twisted cubics k^3 may be divided into four types according to the different sections of the curve by the plane at infinity. These are the *cubical parabola*, *cubical hyperbolic parabola*, *cubical ellipse* and *cubical hyperbola* if the plane at infinity meets the curve at three coincident points, at two coincident points and one real point, at one real and two imaginary points and at three real and different points, respectively [15, p. 353].

Below we will use the following canonical form of a twisted cubic $k^3 = (k_1(t), k_2(t), k_3(t))$

$$\mathbf{k}(t) = \left(\frac{a_1 t}{k}, \frac{a_2 t + b_2 t^2}{k}, \frac{a_3 t + b_3 t^2 + c_3 t^3}{k} \right), t \in \mathbb{R}, \quad (22)$$

where k equals $1, 1 - t, 1 + t^2$ or $1 - t^2$ which specify a cubical parabola, cubical parabolic hyperbola, cubical ellipse or cubical hyperbola, respectively [4, pp. 69-76], [8, p. 928]. Specially, for $k = 1 + t^2, a_1 = b_2, a_2 = b_3 = 0, a_3 = c_3$, eq. (22) represents a cubical circle.

These curves for $a_1 = b_2 = c_3 = 1$ and $a_2 = a_3 = b_3 = 0$, lying on the corresponding 2nd degree cones, are shown in Fig. 18.

The union of the tangent and secant lines of a twisted cubic k^3 fill up the projective space \mathbb{P}^3 and the lines are pairwise disjoint, except at the points of the curve itself [10, p. 90]. Thus, the system of lines meeting a twisted cubic twice is the 1st order 3rd class congruence \mathcal{K}_3^1 with the singular points on the directing curve k^3 . The rays of \mathcal{K}_3^1 can be

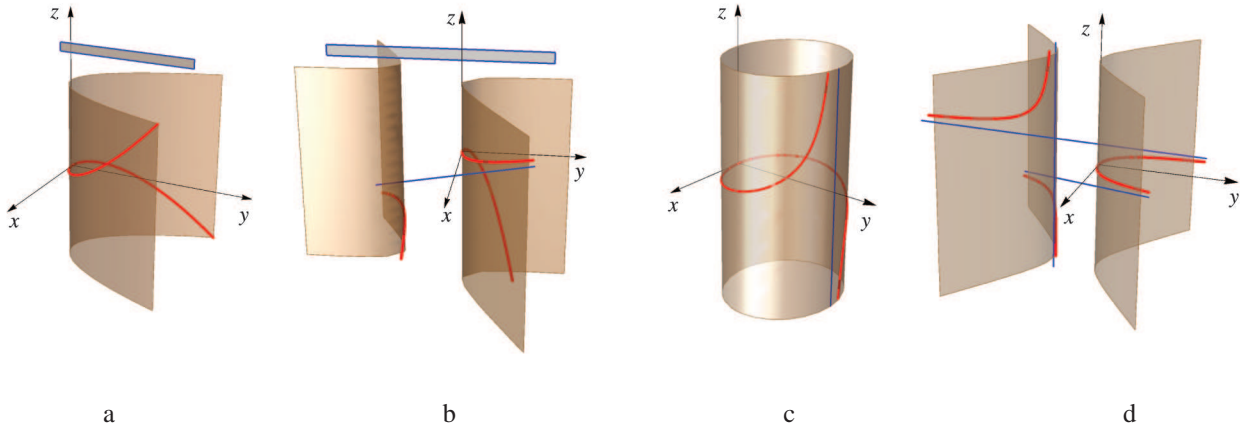

Figure 18: The cubical parabola, parabolic hyperbola, ellipse and hyperbola are shown in figures a, b, c and d, respectively. Their points at infinity are: $(0:0:1:0)$ counted three times in case a, $(1:1:1:0)$ and $(0:0:1:0)$ counted twice in case b, $(0:0:1:0)$ and the pair of imaginary points $(\pm i:-1:\mp i:0)$ in case c and $(\pm 1:1:\pm 1:0), (0:0:1:0)$ in case d, where the points are expressed in standard homogeneous Cartesian coordinates.

expressed by the following equations:

$$\frac{x - k_1(u)}{k_1(v) - k_1(u)} = \frac{y - k_2(u)}{k_2(v) - k_2(u)} = \frac{z - k_3(u)}{k_3(v) - k_3(u)}, \quad (23)$$

$$(u, v) \in \mathbb{R}^2.$$

5.2 Pedal surface \mathcal{PK}_2^5

Let P be any finite point in \mathbb{E}^3 and k^3 the directing curve of \mathcal{K}_3^1 . The pedal surface of \mathcal{K}_3^1 with respect to the pole P is denoted \mathcal{PK}_2^5 . The rays of \mathcal{K}_3^1 through any point $K \in k^3$ form a 2nd degree cone ζ_K with the vertex K (see Fig. 19a). The feet of the perpendiculars from P on the rulings of ζ_K lie on the sphere σ_K with the diameter \overline{PK} . Thus, we can regard the pedal surfaces \mathcal{PK}_2^5 as the system of the 1st kind of quartic curves – the intersection curves of ζ_K and σ_K (see Fig. 19b).

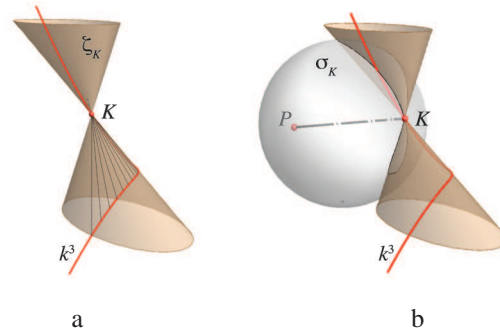

Figure 19: The rays of \mathcal{K}_3^1 through $K \in k^3$ form a 2nd degree cone ζ_K with the vertex K (a). σ_K is a sphere with the diameter \overline{PK} . The intersection curve of ζ_K and σ_K lies on the pedal surface \mathcal{PK}_2^5 (b).

Proposition 9 *The pedal surface \mathcal{PK}_2^5 is a 5th order surface passing through the pole P and the absolute conic.*

PROOF: The proof of this proposition is given in [11]. \square

Proposition 10 *The twisted cubic k^3 is the double curve of \mathcal{PK}_2^5 and ten pinch-points exist on it.*

PROOF: For every point $K \in k^3$, the intersection curve of ζ_K and σ_K is a 4th order space curve with the double point K . The tangent lines of this curve at K are the intersection rulings of the cone ζ_K and the plane through K perpendicular to PK . Thus, there are two tangent planes of \mathcal{PK}_2^5 at $K \in k^3$, determined by the tangent line of k^3 at K and two tangent lines of the curve $\zeta_K \cap \sigma_K$ at K . If the two tangent lines of $\zeta_K \cap \sigma_K$ at K are real and different, coinciding or imaginary, K is the binodal point, pinch-point or isolated point of \mathcal{PK}_2^5 , respectively (see Fig. 20). The proof that on a 5th order surface with a double twisted cubic ten pinch-points can exist is given in [18, p. 312]. These points can be real or imaginary. \square

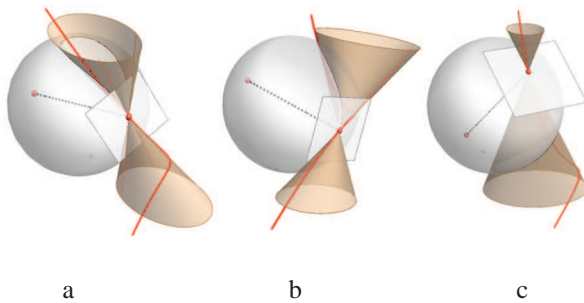

Figure 20: *On the twisted cubic the intersection curve of σ and ζ has a node, cusp or isolated double point shown in figure a, b and c, respectively.*

Proposition 11 *If the pole P lies on the directing curve k^3 , P is the triple point of \mathcal{PK}_2^5 .*

PROOF: It is clear that if $P \in k^3$, then every curve $\zeta_K \cap \sigma_K$, $K \in k^3$ passes through P . The tangent lines of $\zeta_K \cap \sigma_K$ at P are the result of an (1, 1) correspondence between one second degree envelope cone with the vertex P and one pencil of planes through the line passing through P . Thus, according to the Chasles formula [13, p. 40], these tangent lines form a third degree cone with a vertex P . Namely, every tangent line of $\zeta_K \cap \sigma_K$ at P is the intersection of the plane through P perpendicular to PK (the tangent plane of σ_K at P), and the tangent plane of ζ_K at P . The planes through P perpendicular to PK , $K \in k^3$ form a second degree envelope cone with a vertex P . Since the tangent planes of ζ_K at P are determined by the lines PK and t_P , where t_P is the tangent line of k^3 at P , they form the pencil of planes $[t_P]$. \square

Proposition 12 *The ray at infinity of \mathcal{K}_3^1 lies on the pedal surface \mathcal{PK}_3^5 .*

PROOF: Orthogonality in Euclidean space means polarity with respect to the absolute conic – a line l with the point at infinity L^∞ is perpendicular to a plane π with the line at infinity p^∞ iff L^∞ is the pole of p^∞ with respect to the absolute conic. Every ray of \mathcal{K}_3^1 cuts \mathcal{PK}_3^5 at two double points on k^3 and the intersection point with the corresponding plane through P perpendicular to this ray. Since the ray at infinity corresponds with the pencil of planes, every point on it lies on \mathcal{PK}_3^5 . \square

According to the straight lines at infinity, we divide the pedal surfaces \mathcal{PK}_3^5 into the following four types:

- Type I \mathcal{PK}_3^5 has one real straight line counted three times at infinity. The directing curve k^3 is a cubical parabola.
- Type II \mathcal{PK}_3^5 has two real straight lines at infinity, and one of them is counted twice. The directing curve k^3 is a cubical hyperbolic parabola.
- Type III \mathcal{PK}_3^5 has one real and a pair of imaginary straight lines at infinity. The directing curve k^3 is a cubical ellipse.
- Type IV \mathcal{PK}_3^5 has three real and different straight lines at infinity. The directing curve k^3 is a cubical hyperbola.

5.3 Parametric and implicit equations of \mathcal{PK}_2^5

Let the pole P be given by the vector $\mathbf{p} = (p_x, p_y, p_z)$, and let the directing line k^3 of \mathcal{K}_3^1 be the twisted cubic given by the vector function (22). The ray of \mathcal{K}_3^1 passing through the points $K(u), K(v) \in k^3$ can be expressed by the following equation:

$$\mathbf{r}_1(u, v) = \mathbf{k}(u) + s \mathbf{d}(u, v), \quad s \in \mathbb{R}, \quad (24)$$

where $\mathbf{d}(u, v)$ is the direction vector of the line $K(u)K(v)$, i.e. $\mathbf{d}(u, v) = \mathbf{k}(v) - \mathbf{k}(u)$.

The plane through the pole P , perpendicular to the ray $K(u)K(v)$, is given by the following vector equation:

$$(\mathbf{r}_2(u, v) - \mathbf{p}) \cdot \mathbf{d}(u, v) = 0. \quad (25)$$

Since the point on the pedal surface \mathcal{PK}_2^5 is the intersection of the ray (24) and the plane (25), for this point the parameter s satisfies the following equation:

$$s(u, v) = \frac{(\mathbf{p} - \mathbf{k}(u)) \cdot \mathbf{d}(u, v)}{\|\mathbf{d}(u, v)\|^2}. \quad (26)$$

Thus, the parametric equations of \mathcal{PK}_2^5 are:

$$\begin{aligned} x(u, v) &= k_1(u) + d_1(u, v) \cdot s(u, v) \\ y(u, v) &= k_2(u) + d_2(u, v) \cdot s(u, v) \\ z(u, v) &= k_3(u) + d_3(u, v) \cdot s(u, v), \quad (u, v) \in \mathbb{R}^2. \end{aligned} \quad (27)$$

This parametrization does not yield satisfactory *Mathematica* visualizations of \mathcal{PK}_2^5 . Therefore, to draw figures 21 and 22 we used the implicit equations of \mathcal{PK}_2^5 which can be derived from the equations of corresponding spheres σ and cones ζ .

For any point $K(t) \in k^3$, $t \in \mathbb{R}$, the implicit equation of the sphere $\sigma_{K(t)}$ is the following:

$$\left(x - \frac{p_x + k_1(t)}{2}\right)^2 + \left(y - \frac{p_y + k_2(t)}{2}\right)^2 + \left(z - \frac{p_z + k_3(t)}{2}\right)^2 = \frac{1}{4}((p_x - k_1(t))^2 + (p_y - k_2(t))^2 + (p_z - k_3(t))^2). \quad (28)$$

The implicit equation of the cone $\zeta_{K(t)}$ can be derived by eliminating parameters u and v from the following parametric equations:

$$\begin{aligned} x &= k_1(t) + u \cdot d_1(t, v) \\ y &= k_2(t) + u \cdot d_2(t, v) \\ z &= k_3(t) + u \cdot d_3(t, v) \quad (u, v) \in \mathbb{R}^2. \end{aligned} \quad (29)$$

Now, if we eliminate the parameter t from the corresponding implicit equations of $\zeta_{K(t)}$ and $\sigma_{K(t)}$, we obtain the implicit equation of \mathcal{PK}_3^5 . According to propositions 9, 12 and theorem 1 this equation takes the following form:

$$\begin{aligned} &(x^2 + y^2 + z^2)H_1^3(x, y, z) + H^4(x, y, z) \\ &+ H_2^3(x, y, z) + H^2(x, y, z) = 0, \end{aligned} \quad (30)$$

where $H^i(x, y, z)$ are homogeneous polynomials of degree i . The equation $H_1^3(x, y, z) = 0$ represents three rays of \mathcal{K}_3^1 at infinity and $H^2(x, y, z) = 0$ represents the tangent cone of \mathcal{PK}_3^5 at the origin.

Equation (30) depends on nine parameters $(a_1, a_2, a_3, b_2, b_3, c_3, p_x, p_y, p_z)$ and it is incongruously to write them

here even for the special cases. As an appendix to this paper, the reader can download one *Mathematica* notebook available on-line: <http://www.grad.hr/sgorjanc/pedalSKP53.nb>.

5.4 Examples of \mathcal{PK}_2^5

We consider \mathcal{PK}_2^5 where the directing twisted cubic is given by eq. (22) for

$$a_1 = b_2 = c_3 = 1, \quad a_2 = a_3 = b_3 = 0. \quad (31)$$

Type I – the directing curve k^3 is a cubical parabola given by eqs. (22) and (31) for $k = 1$. The pedal surface has a real line at infinity counted three times. In the standard Cartesian coordinates $(x : y : z : w)$, this line is given by the equations $x^3 = 0, w = 0$. See Fig. 21a and Fig. 22a.

Type II – the directing curve k^3 is a cubical hyperbolic parabola given by eqs. (22) and (31) for $k = 1 - t$. The pedal surface has two real lines, one of them counted twice, at infinity. They are given by the equations $x(x - y)^2 = 0, w = 0$. See Fig. 21b and Fig. 22b.

Type III – the directing curve k^3 is a cubical ellipse given by eqs. (22) and (31) for $k = 1 + t^2$. The pedal surface has one real and a pair of imaginary lines at infinity. They are given by the equations $(x^2 + y^2)(x + z) = 0, w = 0$. See Fig. 21c and Fig. 22c.

Type IV – the directing curve k^3 is a cubical hyperbola given by eqs. (22) and (31) for $k = 1 - t^2$. The pedal surface has three real lines at infinity. They are given by the equations $(x - y)(x + y)(x - z) = 0, w = 0$. See Fig. 21d and Fig. 22d.

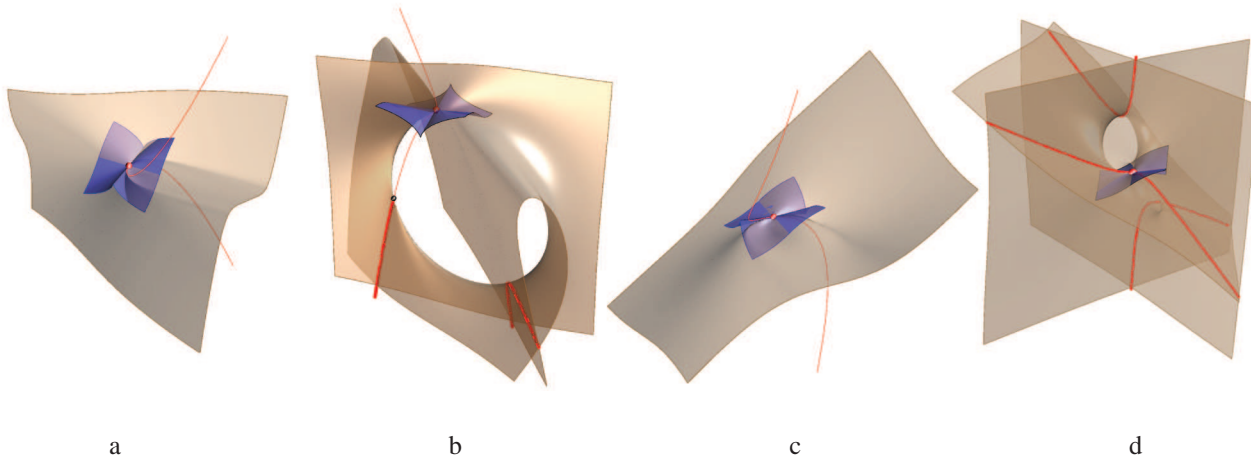

Figure 19: \mathcal{PK}_3^5 of types I, II, III and IV, for $P(0,0,0)$, are shown in figures a, b, c and d, respectively. The 3rd degree tangent cone at P has a cuspidal edge.

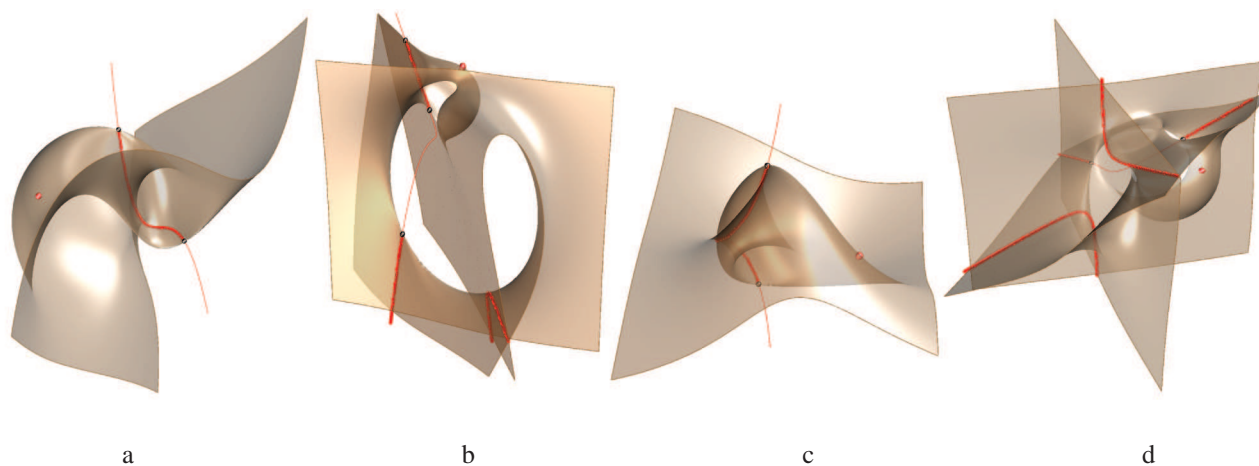

Figure 22: Figure a – \mathcal{PK}_3^5 type I for $P(4, 4, 0)$; figure b – \mathcal{PK}_3^5 type II for $P(2, -1, 3)$; figure c – \mathcal{PK}_3^5 type III for $P(1, 2, 0)$; figure d – \mathcal{PK}_3^5 type IV for $P(5, -1, 3)$.

References

- [1] V. BENIĆ, S. GORJANC, Inversion of degree $n + 2$. Acta Mathematica Hungarica, **122**, 3, 237-253, (2009)
- [2] V. BeniĆ, S. Gorjanc, (1,n) Congruences. KoG, 10, 5-12, (2006)
- [3] Encyclopaedia of Mathematics - SpringerLink. Edited by M. Hazewinkel, available on-line: <http://eom.springer.de/C/c024910.htm>
- [4] K. FLADT, A. BAUR, Analytische Geometrie spezieller Flächen und Raumkurven. Friedr. Vieweg & Sohn, Braunschweig, (1975)
- [5] S. GORJANC, V. BENIĆ, Special Sextics with Quadruple Line, Math. Commun. Vol. **14**, No. 1, 85-103, (2009)
- [6] S. GORJANC, Classification of the Pedal Surfaces of (1,2) Congruences. PhD thesis, Mathematical department, Faculty of Science, University of Zagreb, (2001) (in Croatian).
- [7] S. GORJANC, Special nth Order Surfaces with (n-2)-ple Line. Proc. of 13th International Conference on Geometry and Graphics, Dresden, (2008)
- [8] A. GRAY, Modern Differential Geometry of Curves and Surfaces with Mathematica. CRC Press, Boca Raton, (1998)
- [9] J. HARRIS, Algebraic Geometry. Springer, New York, (1995)
- [10] J. HARRIS, Algebraic Geometry: A First Course. Springer, New York, (1992)
- [11] E. KRANJČEVIĆ, Die Fusspunktflächen der linearen Kongruenzen, Glasnik matematički, 3 (23), 269-274, (1968)
- [12] G. LORIA, Spezielle algebraische und transzendente ebene Kurven. B. G. Teubner, Leipzig-Berlin, (1910)
- [13] E. MÜLLER, J. L. KRAMES, Konstruktive Behandlung der Regelflächen, Franc Deuticke, Leipzig und Wien, (1931)
- [14] V. NIČE, Synthetic Geometry, Školska knjiga, Zagreb, (1956) (in Croatian).
- [15] G. SALMON, A Treatise on the Analytic Geometry of Three Dimensions, Vol.I., Chelsea Publishing Company, New York, (1958)
- [16] G. SALMON, A Treatise on the Analytic Geometry of Three Dimensions, Vol.II. Chelsea Publishing Company, New York, (1965)
- [17] G. SALMON, Higher Plane Curves. Chelsea Publishing Company, New York, (1960)
- [18] R. STURM, Die Lehre von den geometrischen Verwandtschaften, Band IV. B. G. Taubner, Leipzig-Berlin, (1909)
- [19] R. STURM, Liniengeometrie, II. Teil. B. G. Taubner, Leipzig, (1893)
- [20] R. VIHER, On the Multiple Roots of the 4th Degree Polynomial, KoG, 11, 25-31,(2007)

- [21] Wikipedia – The Free Encyclopedia. Available on-line: http://en.wikipedia.org/wiki/Integer_partition
- [22] K. ZINDLER, *Algebraische Liniengeometrie*, Encyclopädie der Mathematischen Wissenschaften, Band III, 2. Teil, 2. Hälfte. A., pp. 1184-1185, B. G. Teubner, Leipzig, (1921-1928)

Sonja Gorjanc

Faculty of Civil Engineering, University of Zagreb
Kačićeva 26, 10000 Zagreb, Croatia
e-mail: sgorjanc@grad.hr

The author would like to thank her colleague Vladimir Benić and Prof. Otto Röschel for their valuable suggestions which have improved the quality of this paper.