

Vladivoj VALKOVIĆ¹
Dario MATIKA²
Davorin SUDAC³

Inspecting the Inside of Sunken Ships and Ship's Underwater Hull

Original scientific paper

In order to demonstrate the possibility of identifying the material within ship's underwater hull, sunken ships, or other objects on the sea floor, tests with a 14 MeV sealed tube neutron generator incorporated inside a small submarine were performed in the test basin filled with sea water. The results obtained for inspection of diesel fuel and explosive presence behind single and double hull structures are presented.

Keywords: *neutron interrogation, explosive, diesel fuel, sunken ships, ship hull*

Authors' addresses (Adrese autora):

¹ A.C.T. d.o.o., Prilesje 4, 10000 Zagreb, Croatia

² Institute for Research and Development of Defence Systems, Illica 256b, 10000 Zagreb

³ Rudjer Boskovic Institute, P.O. Box 180, 10002 Zagreb, Croatia

Received (Primljeno): 2009-09-15

Accepted (Prihvaćeno): 2010-02-2

Open for discussion (Otvoreno za raspravu): 2011-03-31

Kontrola unutrašnjosti potopljenih brodova i podvodnih dijelova broda

Izvorni znanstveni rad

S ciljem demonstracije mogućnosti identifikacije materijala unutar podvodnog dijela broda, unutar potopljenih brodova i ostalih predmeta na morskom dnu, izvršeni su eksperimenti sa cijevnim 14 MeV neutronske generatorom smještenim unutar male podmornice u bazenu napunjenom morskom vodom. Prikazani su rezultati dobiveni inspekcijom dizelskog goriva i eksploziva smještenih iza jednostruke i dvostruke konstrukcije trupa broda.

Ključne riječi: *neutronska inspekcija, eksploziv, dizelsko gorivo, potopljeni brodovi, trup broda*

1 Introduction

Many of the materials on the bottom of the seas are due to numerous shipwrecks. There is a global risk of marine pollution from over 7800 sunken World War II vessels worldwide. Numerous efforts are made to compile data on WWII shipwrecks. The recent efforts include so called South Pacific Regional Environment Programme (SPREP) and AMIO databases of WWII shipwrecks [1-3]. Although work on the Pacific SPREP database is relatively complete, work on shipwrecks in other oceans has only recently commenced. The Atlantic, Mediterranean and Indian Ocean (AMIO) WWII shipwreck database of is in its initial stages. Currently, the AMIO database contains information on the location and ownership of over 3953 WWII vessels, over

1000 gross tons, equalling to over 20 million tons of shipping, lying at the bottom of world's oceans. The distribution of WWII shipwrecks from both databases is shown in Table 1.

Some areas in Europe are of special interest because of large amounts of dumped ammunitions. These include the Baltic Sea, the Atlantic Ocean and the North Sea, and the Mediterranean [4-8].

Inspection of the cargo area within the ship's body below water surface for the presence of threat materials is also required in the fight against terrorist activities. In such a scenario a detection system needs to approach the ship's underwater hull and analyze the material present at the other side of the ship's hull, i.e. in the ship's cargo area.

Even though boat and ship building dates back to ancient times, some production technologies have been slow to change, illustrated by an only recent shift in technology at major shipyards. The building of large ships is one of the most obvious applications of heavy plate fabrication. Iron vessels were first built on a regular basis in England in the 1830s, and the first such naval fighting vessel was used in England's First China War of 1841-43. Steel began to replace iron construction in the 1870s as steel became more affordable [9]. Modern commercial ship hulls continue to be built with 14- to 19-millimeter-thick (0.5- to 0.75-inch) plate. Carbon steel is low-cost and easy to repair. These materials normally are specified American Bureau of Shipping grade A, although sometimes grades B and H are used.

Early hulls were riveted, but this approach evolved to 100 percent welded seams by World War II. The submerged arc

Table 1 **AMIO & SPREP shipwreck databases – Distribution of shipwrecks globally**

Tablica 1 **AMIO & SPREP baze podataka brodskih olupina – globalna distribucija**

Ocean/seas	Number of vessels	Total tonnage	Number of tankers
North Atlantic	3002	15108305	452
South Atlantic	198	1143374	20
Mediterranean	305	1578910	19
Indian	313	1813398	35
Arctic	124	729569	2
Pacific	3276	12158895	273

welding (SAW) process makes up the majority of welding today, using ceramic backup strips where possible to maximize one-side welding. Double-hull construction is a fairly recent and major design change that affected fabrication and assembly. This was dictated by the Oil Pollution Act of 1990, with the goal of reducing the risk of major environmental disasters caused by fuel and leaking oil and petroleum cargoes. Tanker hulls must be made with double construction, while other transport vessels, such as those for containers and bulk dry cargo, must have double-hull construction only in their fuel tank areas. While the outer hull is 14 to 19 mm thick, the inner hull may be 12 to 14 mm thick.

Only the outer hull details are shaped to contour; inner hull details are designed to allow fabrication from flat plate. Power rolling shapes the outer hull components that require simple curvature, with contour checked against CAD-generated templates. Parts that need compound curvature are formed by selective heating. The latter method requires the skill and experience of craftsmen who now can refer to a CAD-generated graphic matrix, which predicts specific locations and amounts of heat to be applied.

For today's large naval combat vessels, aluminium is used for lighter-weight topside structure, and composites that resist corrosion are used for secondary items such as gratings and decking. However, steel continues to be the material of choice for hull structure. HSLA (high-strength, low-alloy) steel use has evolved over the last 20 to 30 years. Its advantages include increased strength and reduced thickness, which provides a weight saving that, in turn, reduces fuel consumption.

2 Experimental

It is often required to inspect ship hulls, either to detect potential anomalies attached to the hull, or to determine the nature of materials within the hull, especially in the case of sunken ships. The material to be inspected is hidden behind the tanker walls having a thickness up to 25 mm in older ships, while in the modern ones the walls are only 14 to 16 mm thick. In addition, the new tankers are required to have double hull construction, outer hull 14-19 mm thick (shaped to contour), and inner hull 12-14 mm thick (flat plate).

In order to demonstrate the possibility of identifying the material within sunken ships and other objects on the sea floor, we have performed tests with the 14 MeV sealed tube neutron generator incorporated inside a small submarine submerged in the test basin filled with sea water [10].

The principle of the method used is demonstrated in Figure 1.

Figure 1 The principle of the tagged neutron sensor
Slika 1 Princip rada senzora koji koristi obilježene neutrone

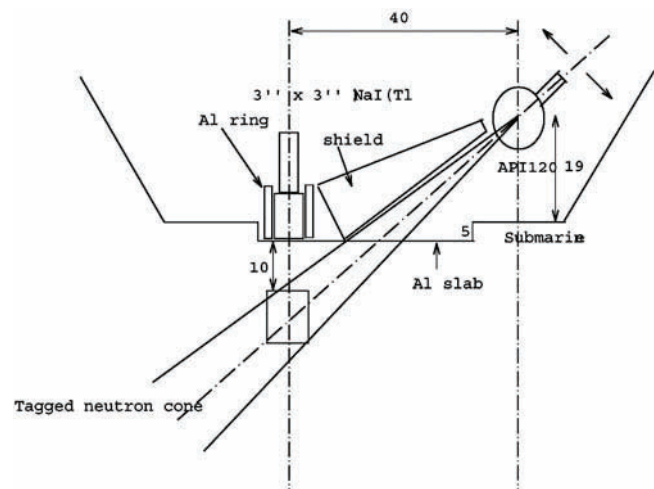
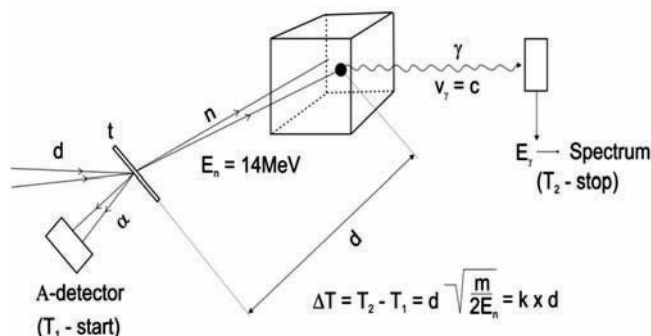

Figure 2 Geometrical arrangement of the neutron sensor
Slika 2 Geometrijski prikaz neutronskog senzora

The geometrical arrangement for the experiment is shown in Figure 2. The investigated targets were 10 litres of diesel fuel, 5 kg of explosive and different chemicals (expected components of chemical warfare agents) placed behind a 16-mm steel plate in the first measurement and behind a sandwich of 18-mm steel plate – 10-cm air bag – 16-mm steel plate in the second measurement respectively.

Using the window on the measured alpha-gamma time spectrum, the gamma rays originating from the investigated volume were separated from the background radiation. By the inspection of the measured gamma spectra we were able to identify all the investigated materials in both measurement geometries.

The inspection system, the experimental set-up and the presentation of the performed measurement are given in Figures 3 to 6. The measurement results are presented in Figures 7 to 13.

Figure 3 Inspection system to be submerged into the water pool
Slika 3 Sistem za inspekciju pripremljen za uron u bazen napunjen vodom

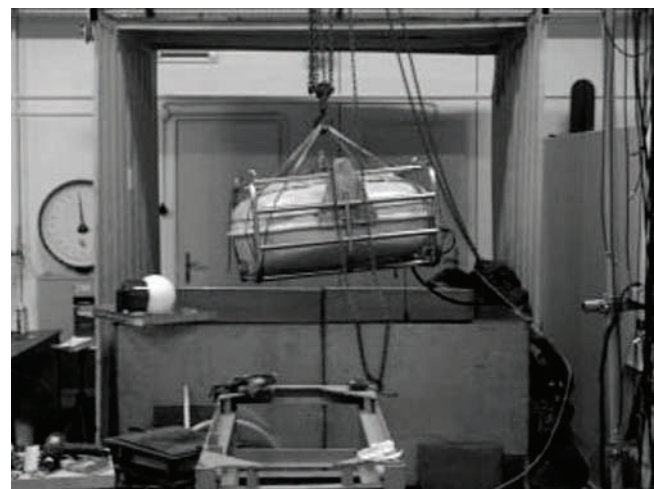



Figure 4 Schematic presentation of the experimental set-up for double hull construction, outer hull 14-19 mm thick, inner hull 12-14 mm thick

Slika 4 Shematski prikaz eksperimentalnog postava za konstrukciju dvostrukog trupa, vanjski trup debljine 14-19 mm, unutarnji trup debljine 12-14 mm



Figure 5 Double hull construction, the air bag is placed between two iron plates so that the whole set-up can be immersed in water

Slika 5 Dvostruki trup: zrakom ispunjen jastuk postavljen između dvije željezne ploče tako da čitav postav može uroniti u vodu

Figure 6 Schematic presentation of the performed measurements; targets were TNT explosive (5 kg) and diesel fuel (10 l), the submarine was positioned about 2 cm above the upper iron plate

Slika 6 Shematski prikaz izvršenih mjerenja; mete su bile TNT eksploziv (5 kg) i dizelsko gorivo (10 litara), podmornica je pozicionirana 2 cm iznad gornje ploče

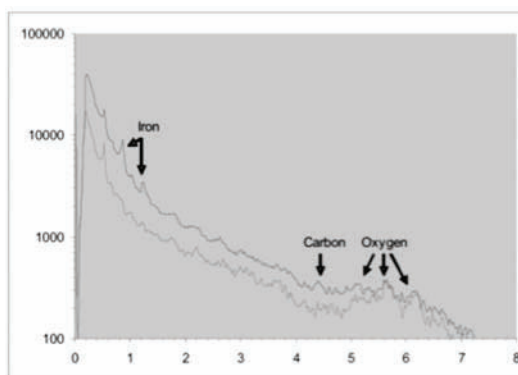
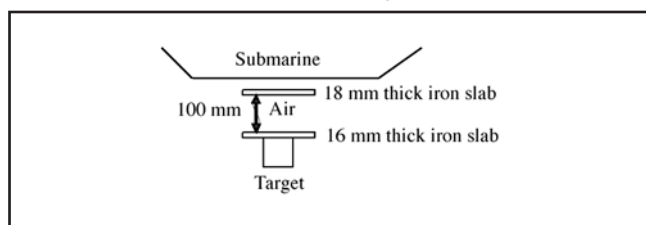

Figure 7 Gamma ray spectra from TNT (5 kg) target (top line), logarithmic scale; target out (bottom line); the total number of the tagged neutrons 24×10^7 ; measurement time: ~ 6900 s

Slika 7 Spektar gama zraka iz mete TNT (5 kg) – gornja krivulja, logaritamska skala; donja krivulja je bez mete; ukupni broj označenih neutrona 24×10^7 ; vrijeme mjerenja: ~ 6900 s

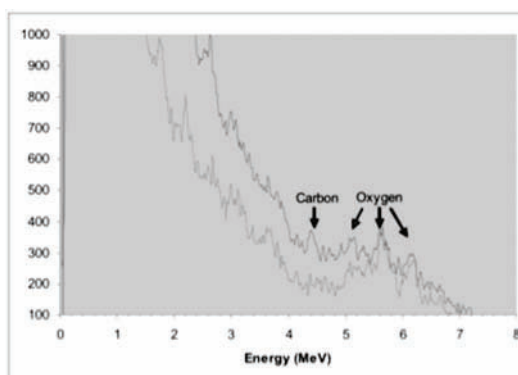
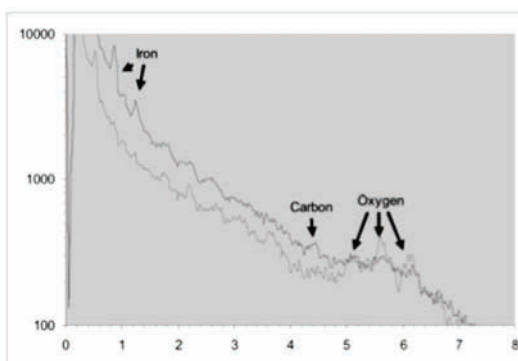

Figure 8 Gamma ray spectra from TNT (5 kg) target (top line), linear scale; target out (bottom line); the total number of the tagged neutrons 24×10^7 ; measurement time: ~ 6900 s

Slika 8 Spektar gama zraka iz mete TNT (5 kg) – gornja krivulja, linearna skala; donja krivulja je bez mete; ukupni broj označenih neutrona 24×10^7 ; vrijeme mjerenja: ~ 6900 s

Figure 9 Gamma ray spectra from diesel fuel (10 l), top line, behind the iron-air-iron sandwich in the sea water, logarithmic scale; target out: bottom line; total number of tagged neutrons 18×10^7 ; measurement time: ~ 5240 s

Slika 9 Spektar gama zraka iz mete dizelskog goriva (10 l) iza željezo-zrak-željezo sendviča – gornja krivulja, logaritamska skala, donja krivulja je bez mete; ukupni broj označenih neutrona 18×10^7 ; vrijeme mjerenja: ~ 5240 s



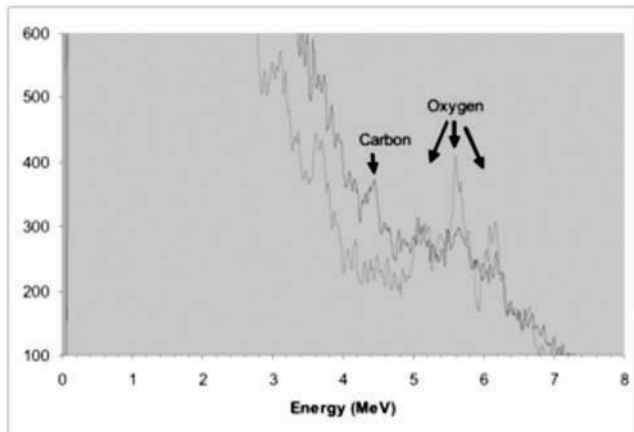

Figure 10 Gamma ray spectra from diesel fuel (10 l), top line, behind the iron-air-iron sandwich in the sea water, linear scale, target out: bottom line; total number of tagged neutrons 18×10^7 ; measurement time: ~ 5240 s

Slika 10 Spektar gama zraka iz mete dizelskog goriva (10 l) iza željezo-zrak-željezo sendviča – gornja krivulja, linearna skala; donja krivulja je bez mete; ukupni broj označenih neutrona 18×10^7 ; vrijeme mjerenja: ~ 5240 s

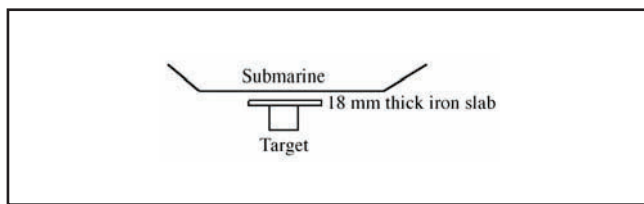

Figure 11 Schematic presentation of the experimental set-up (single hull); the whole set-up is immersed in water; targets were TNT explosive (5 kg) and diesel fuel (10 l); the submarine was positioned about 2 cm above the iron plate

Slika 11 Shematski prikaz eksperimentalnog postava (jednostruki trup); čitav je postav uronjen u vodu, mete su bile TNT eksploziv (5 kg) i dizelsko gorivo (10 l); podmornica je pozicionirana na 2 cm iznad željezne ploče

Figure 12 Gamma spectrum from diesel fuel behind the iron plate 16 mm thick (12×10^7 tagged neutrons, measurement $t = 3438$ s)

Slika 12 Spektar gama zraka iz dizelskog goriva smještenog iza željezne ploče debljine 16 mm (12×10^7 označenih neutrona, vrijeme mjerenja $t = 3438$ s)

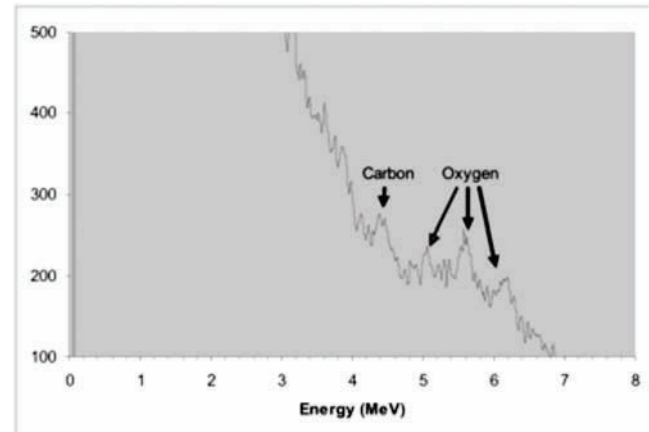
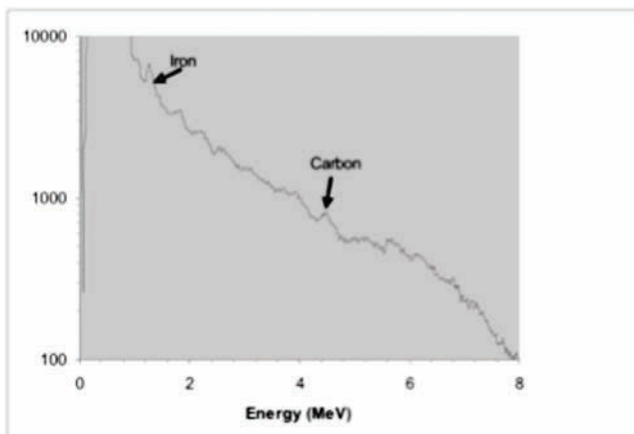
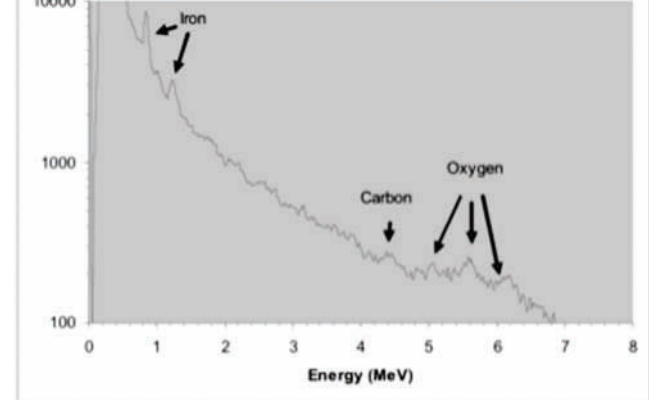

Figure 13 Gamma spectrum from 5 kg of TNT behind the iron plate 16 mm thick (12×10^7 tagged neutrons, measurement time 3490 s); logarithmic scale – bottom; linear scale – top



Slika 13 Spektar gama zraka iz 5 kg TNT smještenog iza željezne ploče debljine 16 mm (12×10^7 označenih neutrona, vrijeme mjerenja 3490 s); logaritamska skala – donja slika; linearna skala – gornja slika

Figure 13 Gamma spectrum from 5 kg of TNT behind the iron plate 16 mm thick (12×10^7 tagged neutrons, measurement time 3490 s); logarithmic scale – bottom; linear scale – top

Slika 13 Spektar gama zraka iz 5 kg TNT smještenog iza željezne ploče debljine 16 mm (12×10^7 označenih neutrona, vrijeme mjerenja 3490 s); logaritamska skala – donja slika; linearna skala – gornja slika

The thickness of the iron plate positioned between the submarine and the explosive (mass 5 kg) was varied. Submarine to explosive (mass 5 kg) distance was 11 cm. The graph in Figure 14 shows the number of counts in carbon 4.44 MeV peak (black) and oxygen 5.62 MeV peak – first escape peak of oxygen 6.13 MeV line (red) as a function of iron plate thickness.

Solid lines correspond to the exponential fit ($a e^{-bx}$). The total number of tagged neutrons in each measurement was 3.6×10^8 , with neutron beam of $\sim 10^7$ n/s corresponding to the measurement time of ~ 176 min. The measurements were done for a long time period in order to obtain better statistics. Conclusions on the existence of peaks can be reached in much shorter time.

Table 2 contains the parameters of the exponential fit ($a e^{-bx}$) shown in Figure 14.

Table 2 Parameters of the exponential fit ($a e^{-bx}$) shown in Figure 14Tablica 2 Parametri eksponencijalnog fita ($a e^{-bx}$) prikazanog na slici 14

Element	a	b (1/mm)
Carbon	6169 ± 318	0.043 ± 0.004
Oxygen	2379 ± 411	0.05 ± 0.02

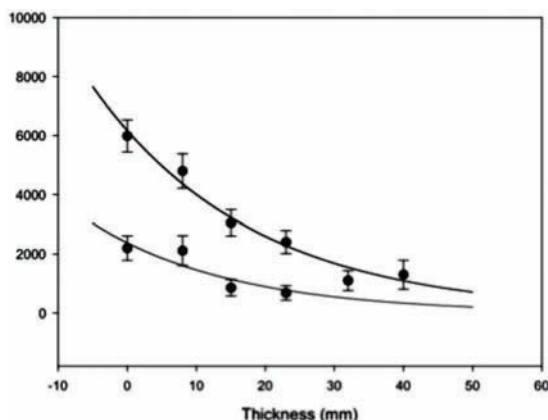

Figure 14 The number of counts in carbon 4.44 MeV peak (upper) and oxygen 5.62 MeV peak – first escape peak of oxygen 6.13 MeV line (lower) as a function of iron plate thickness

Slika 14 Broj događaja u ugljikovom vrhu 4,44 MeV (gornja krivulja) i kisikovom sekundarnom vrhu 5,62 MeV, od 6,13 MeV linije (donja krivulja) u funkciji debljine željezne ploče

The number of counts in 4.44 MeV carbon peak for different iron plate thicknesses is shown in Table 3, while Table 4 gives the number of counts in 5.62 MeV oxygen peak for different iron plate thicknesses under the identical experimental conditions (see above).

Table 3 The number of counts in 4.44 MeV carbon peak for different iron plate thicknesses

Tablica 3 Broj događaja u ugljikovom 4,44 MeV vrhu u funkciji debljine željezne ploče

Thickness (mm)	Number of counts in 4.44 MeV peak	Error
0.0	5985	542
8.0	4797	581
15.0	3053	445
23.0	2405	388
32.0	1101	334
40.0	1303	489

Table 4 The number of counts in 5.62 MeV oxygen peak for different iron plate thicknesses

Tablica 4 Broj događaja u kisikovom 5,62 MeV vrhu u funkciji debljine željezne ploče

Thickness (mm)	Number of counts in 5.62 MeV peak	Error
0.0	2203	413
8.0	2119	506
15.0	857	279
23.0	684	245

In comparison with benign materials, TNT explosive is characterized with a high C/O ratio. However, in the case of thicker iron plates conclusions can be drawn in some situations from the presence of carbon peak only.

3 Conclusions

It is often required to inspect ship hulls, either to detect potential anomalies attached to the hull, or to determine the nature of materials within the hull, especially in the case of sunken ships. Older tanker walls have a thickness up to 25 mm, while the modern ones are only 14 to 16 mm thick. In addition, the new tankers are required to have double hull construction, outer hull 14-19 mm thick (shaped to contour), inner hull 12-14 mm thick (flat plate).

In order to demonstrate the possibility of identifying the material within sunken ships and other objects on the sea floor we performed tests with the 14 MeV sealed tube neutron generator incorporated inside a small submarine submerged in the test basin filled with sea water.

Measurements were performed with the following targets: 10 litres of diesel fuel, 5 kg of explosive and different chemicals (expected components of chemical warfare agents) placed behind a 16-mm steel plate in the first measurement and behind a sandwich of 18-mm steel plate – 10-cm air bag – 16-mm steel plate in the second measurement respectively.

Using the window on the measured alpha-gamma time spectrum, the gamma rays originating from the investigated volume were separated from the background radiation. By the inspection of the measured gamma spectra we were able to identify all the investigated materials in both measurement geometries.

References

- [1] MONFILS, R.: "The Global Risk of Marine Pollution from WWII Shipwrecks: Examples from Seven Seas", Submitted to International Oil Spill Conference, Miami, Florida, 2005.
- [2] ...: SPREP "Regional Strategy to Address Marine Pollution from WWII Shipwrecks in the Pacific". Phase 1-Report and Preliminary Risk Assessment. CD-ROM, 2003.
- [3] ...: OSPAR Commission "Overview of Past Dumping at Sea of Chemical Weapons and Munitions in the OSPAR Maritime Area", Revise, ISBN 1-904426-54-9, 2004.
- [4] ...: Advisory Committee on Protection of the Sea (ACOPS) "Coastal Survey of Packaged Chemical and other Hazardous Items 2002/2003", Maritime and Coastguard Agency Research Project No. 488, London, October 2003. Australian Government, Department of Defense, Chemical Warfare Agent Sea Dumping off Australia, Revised and updated edition 2003, Canberra ACT 2600.
- [5] ...: United Nations Environmental Programme "Dumping Sites of Ammunitions in the Mediterranean Sea", UNEP (DEPI)MED WG. 316/inf. 12 23, May 2007.
- [6] FEDOROV, L.A.: "Pre-Convention Liquidation of Soviet Chemical Weapons" in "Sea-Dumped Chemical Weapons: Aspects, Problems and Solutions", Ed. AV Kaffka, Kluwer, Academic Publishers, Dordrecht, 1996, p 17 - 27.
- [7] ...: HELCOM "Report on Chemical Munitions Dumped in the Baltic Sea", Report to the 16th Meeting of the Helsinki Commission 8-11 March 1994 from the Ad Hoc Working Group on Dumped Chemical Munitions, HELCOM CHEMU, January 1994.
- [8] KAFFKA, A.V.: "Sea-Dumped Chemical Weapons: Aspects, Problems and Solutions". Proceedings of the NATO Advanced Research Workshop on "Sea-Dumped Chemical Munitions", Kaliningrad, Russia, January 12-15, 1995.
- [9] WALDROP, P.S.: "A parting of the (inclined) ways - US shipbuilding sails toward modern fabrication, assembly", September 12, 2002, www.thefabricator.com
- [10] VALKOVIC, V., SUDAC, D., MATIKA, D., KOLLAR, R.: "An underwater system for explosive detection", SPIE Conference, Orlando, 2007, Proc. paper 6540-35.