

EFFECTS OF ALCOHOL-GASOLINE BLENDS ON EXHAUST AND NOISE EMISSIONS IN SMALL SCALED GENERATORS

Received – Prispjelo: 2009-09-18
Accepted – Prihvaćeno: 2009-11-30
Preliminary Note – Prethodno priopćenje

In this study, the effect of methanol or butanol addition to gasoline on exhaust emissions and noise level has been experimentally investigated. Results showed that the concentrations of CO and NO_x emissions were decreased depending on the higher alcohol contents and the carbon monoxide concentration of gasoline was higher than that of methanol or butanol-gasoline blends for all engine loads. It was determined that content of the HC was decreased at higher engine load but noise level was increased.

Key words: environmental protection, exhaust emissions, alcohol-gasoline blends, generators

Djelovanje alkoholno-benzinskih mješavina na emisiju ispušnih plinova i buke kod malih generatora. U ovom radu eksperimentalno je ispitano djelovanje dodataka mentola ili butanola u benzin na emisije ispušnih plinova i na razinu buke. Rezultati su pokazali smanjenje koncentracije emisija CO i NO_x, ovisno o većim udjelima alkohola. Koncentracija CO kod benzina bila je viša nego kod mješavina benzina i metanola ili butanola, za sva opterećenja motora. Utvrđeno je da je pri većem opterećenju motora sadržaj CH smanjen, ali je povećana razina buke.

Ključne riječi: zaštita okoliša, emisije ispušnih plinova, mješavine alkohol-benzin, generatori

INTRODUCTION

The increasing industrialization and motorization of the world has led to a step rise for the demand of petroleum-based fuels. Petroleum-based fuels are obtained from limited reserves. These finite reserves are highly concentrated in certain regions of the world. Therefore, those countries not having these resources are facing energy/foreign exchange crisis, mainly due to the import of crude petroleum. Hence, it is necessary to look for alternative fuels which can be produced from resources available locally within the country such as alcohol, biodiesel, vegetable oils etc. [1].

The simple approach to the use of alcohols in spark ignition (SI) engines is to blend moderate amounts of alcohols with gasoline. The second and more technically challenging option is to use alcohols essentially neatly as engine fuel [2]. Alcohols such as methanol (CH₃OH), butanol (C₄H₉OH) and ethanol (C₂H₅OH) have received considerable attention recently because they are considered as highly efficient, and low-polluting future fuels through their lean operating ability [3].

Alcohol burns cleaner than regular gasoline and produce lesser carbon monoxide, HC and oxides of nitrogen [4]. Alcohol has higher heat of vaporization; therefore, it reduces the peak temperature inside the combustion chamber leading to lower NO_x emissions and in-

creased engine power. The oxygen presence in alcohol fuel provides soot-free combustion with low particulate level.

Methanol's most desirable features its high octane quality. Methanol rates 106-115 octane numbers by the research method and 88-92 octane numbers by the motor octane method [5]. Because of these characteristics, methanol is considered to be one of the most likely alternative automotive fuels for SI engines in the foreseeable future [6].

Iso-butanol (C₄H₉OH) is an attractive alcohol fuel because of its high heating value compared to methanol and ethanol. Iso-butanol heating value represents 77 % of gasoline heating value, and it has the advantages of a low affinity for water solubility in blends [7]. The high octane number of iso-butanol makes it inherently adaptable as fuel for conventional spark ignition engine [8].

Various studies were performed related to the usage of alcohols-gasoline blends in spark ignition engines. The effect of methanol and butanol addition to gasoline on brake specific fuel consumption (b.s.f.c.), exhaust gas temperature, and thermal efficiency has been experimentally investigated [9]. The performance measurements show that there is an increase in b.s.f.c. when using alcohol-gasoline blends, and b.s.f.c. of a butanol-gasoline blend is less than for a methanol-gasoline blend. The experimental results show that the engine thermal efficiency was decreased when fueled with alcohol-gasoline blends. Alasfour [10] investigated the ef-

A. YASAR, Faculty of Technical Education, Mersin University, Tarsus, Turkey

fect of using a 30 % iso-butanol-gasoline blend on NO_x emission in a spark ignition engine. It was observed that by using the 30 % iso-butanol-gasoline blend the maximum level of NO_x emission is reduced by 9 % compared to gasoline and the reduction of NO_x level was evident in the rich region.

Although a great deal of experimental exhaust emissions data at various engine loads in spark ignition engines using ethanol have been accumulated, very few data are available for methanol and butanol as fuel at higher alcohol contents. The aim of this study is to determine the suitable methanol-gasoline and butanol-gasoline blend rate in terms of emissions and noise on a single cylinder spark ignition generator at various engine loads.

MATERIAL AND METHODS

The Lombardini single-cylinder, spark ignition engine which has 8,6 compression ratio, 349 cm³ cylinder volume, air cooling, 7 BG power, 82 mm bore, 66 mm stroke, 4 stroke number and 3000 rpm was used for the experiments.

A Capelec model gasoline engine gas analyzer with the infrared system was used in the experiments. The device has the potential to analyze exhaust gases of gasoline vehicles. Hydrocarbon (HC), Carbon Monoxide (CO), Carbon Dioxide (CO₂) and Nitrogen Oxide (NO_x) were measured by means of this device within the exhaust emissions. Technical properties of test device are given in Table 1.

The exhaust gas sample was carried from the exhaust through a probe passing through a filter and dryer to prevent any water and particulate from entering the analyzer. Measurement distance of exhaust gas analyzer was 1 meter from the engine block. The system was calibrated at the beginning of each test series. The schematic diagram of the experimental setup is shown in Figure 1.

Experiments were performed at 0,8 kW, 1,6 kW and 2,4 kW at partial engine loads. Alcohol-unleaded gasoline blends were prepared by volume measure. Alcohol fuels used were butanol and methanol (industrial grade, CH₃OH, C₄H₉OH, 95 %). Alcohol-gasoline blends used in the experiment were 5 %, 15 %, 25 %, 35 %, 50 % volume both methanol and butanol. The rate of methanol and butanol in blend were called as M and B, respectively. The properties of gasoline, methanol and butanol are given in Table 2.

Table 1 The specifications of the exhaust gas analyzer

| | Measurements range | Accuracy |
|-----------------|--------------------|----------|
| HC | 0-20000 ppm | 1 ppm |
| CO | 0-15 % | 0,001 % |
| CO ₂ | 0-20 % | 0,1 % |
| O ₂ | 0-21,7 % | 0,01 % |
| NO _x | 0-5000 ppm | 1 ppm |

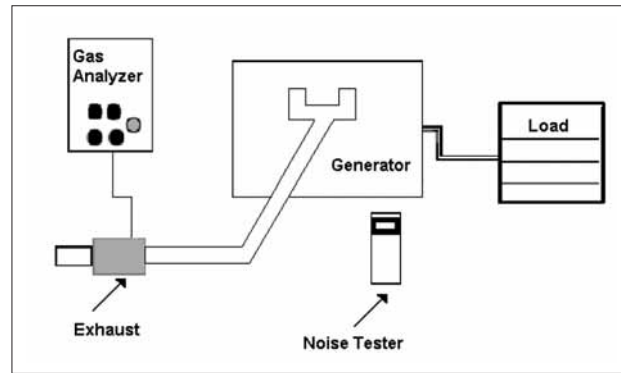

Figure 1 The schematic diagram of the experimental setup

The blends used during the experiments were kept for fifteen day period and it was observed that there was no phase-separation at any blend rate.

The engine was operated for a period of 15 minutes with gasoline to reach steady state operation conditions. Engine temperature was kept under the control during the engine performance test. The tests were conducted 3 times for each of the test fuels and average of the results was taken. A Testo model 816 type noise tester, which is given in Table 3, was also used to measure noise of the engine.

RESULTS AND DISCUSSION

Figure 2 shows the effect of methanol-gasoline and butanol-gasoline blends on CO emissions of engine. CO is toxic gas that is the result of incomplete combustion. When methanol and butanol containing oxygen is mixed with gasoline, the combustion of the engine becomes better and therefore, CO emission is reduced. The similar results were also reported by Rice et al. [11]. The oxygen ratio in blend is 21,62 % in methanol, 50 % in butanol. For this reason, CO emission concentration of methanol was lower than those of butanol. It was observed that by using 50 % methanol-gasoline blend at higher engine loads. CO emission is the least comparing

Table 2 The properties of gasoline, methanol and butanol

| Fuel | Density /kg m ⁻³ | Res. Octane Number | Mot. Octane Number |
|-------------------|-----------------------------|--------------------|--------------------|
| Unleaded Gasoline | 738,7 | 96,787 | 86,758 |
| M5 | 747,3 | 98,785 | 75,737 |
| M15 | 749,3 | 101,658 | 78,197 |
| M25 | 751,8 | 103,337 | 81,647 |
| M35 | 756,4 | 104,905 | 82,490 |
| M50 | 768,3 | 106,625 | 88,837 |
| B5 | 747,1 | 103,932 | 83,681 |
| B15 | 748,9 | 102,574 | 81,653 |
| B25 | 755,8 | 101,665 | 81,359 |
| B35 | 764,2 | 101,646 | 79,701 |
| B50 | 775,7 | 101,442 | 77,382 |

Table 3 Technical data of noise tester

| | |
|---------------------|---------------------|
| Measurement range | +30 to 130 dB |
| Accuracy ± digit | Class 2 ± 1,0 dB |
| Resolution | 0,1 dB |

to other methanol-gasoline % volume blend. In addition, the decrease in CO emissions is also observed when butanol is used.

The effect of various fuels on HC emission is given in Figure 3. At 800 W engine loads, the HC emissions are higher than that of gasoline, when using methanol-gasoline blend and butanol-gasoline blend. As the load increases, the ratio of HC in the emission decreases. Also, HC emission decreases by increasing the % volume of methanol and butanol-gasoline blend. These results are similar to the results of Kim et al. [4], Taylor et al. [12]. As it is shown in Figure 3, dramatic decrease occurs at 50 % of methanol and butanol-gasoline blends for 2400 W engine load.

The effect of various engine loads on NO_x emissions is given in Figure 4.

NO_x is formed as a result of nitrogen and oxygen reaction under high temperature and pressure in the engine cylinder. The heat occurring from the combustion of methanol is low. So, the conditions for high amount of NO_x can not arise [13]. As it is shown in Figure 4, at 800 W engine loads, 35 % methanol-gasoline blend has almost the same NO_x emission, but 50 % methanol-gasoline blend, NO_x emission has a lower value. At 1600 W engine load, NO_x emission is reduced gradually for 50 % and 35 % methanol-gasoline blend with respect to % volume of other blends. But for butanol-gasoline

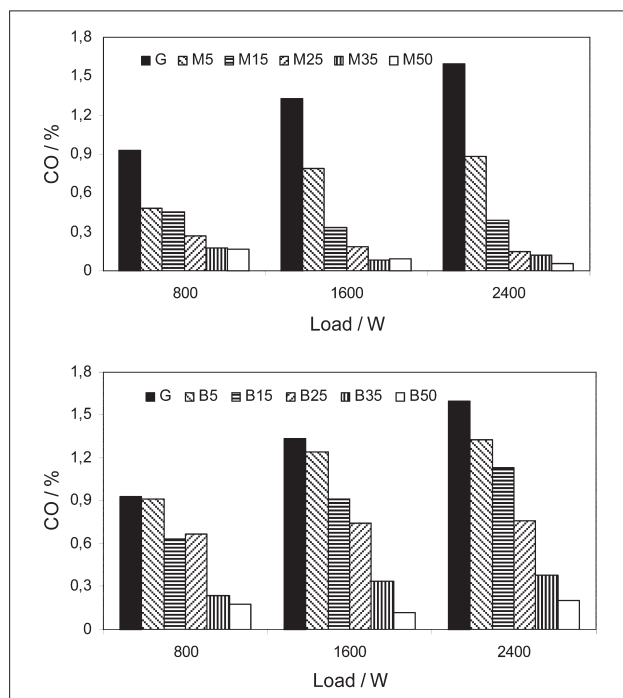

Figure 2 The effect of various engine loads on CO emissions

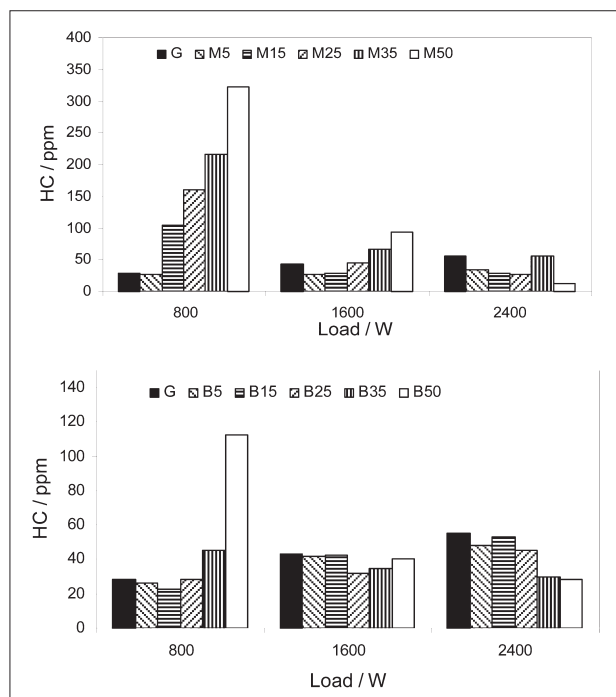

Figure 3 The effect of various engine loads on HC emissions

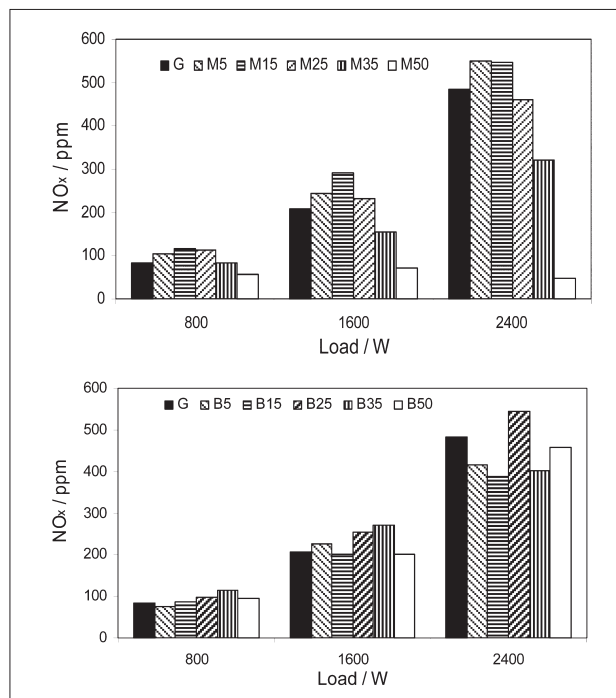

Figure 4 The effect of various engine loads on NO_x emissions

blends as the engine load increases, NO_x emissions also increase. NO_x emission obtained with all butanol-gasoline blends has similar results with gasoline because butanol and gasoline fuels have approximately the same octane number.

Figure 5 shows the effect of methanol and butanol-gasoline blends on CO₂ emissions. CO₂ emission obtained with M 50 fuel is lower than that obtained with gasoline at 2 400 W engine load, but the effect of butanol on CO₂ emissions did not noteworthy change

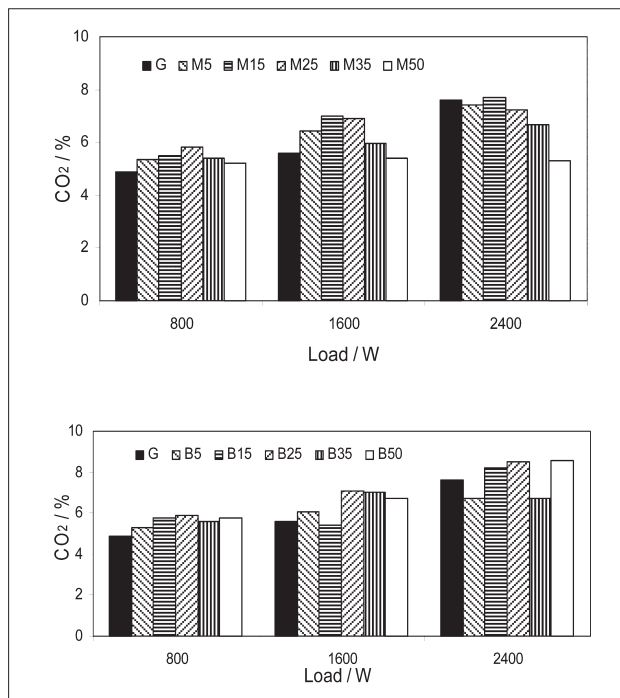

Figure 5 The effect of various engine loads on CO₂ emissions

with respect to % volume of other blends. CO and CO₂ have complementary correlation. That is, with increasing CO₂ emission, the amount of CO decreases. CO₂ emission depends on air-fuel ratio and CO emission concentration [14].

The effect of various engine loads on noise level is given in Figure 6. With increasing engine loads, noise level obtained with methanol and butanol-gasoline blends increases. It was observed that the maximum noise level is 95,5 dB(A) at 2 400 W for M25 and B25 fuel, the minimum noise level is 93,64 dB(A) for M15 and B15 fuels.

CONCLUSIONS

The following features of methanol-gasoline and butanol-gasoline blended engines may be drawn:

1. CO emission concentration of engine operated with methanol-gasoline blend was lower than those of butanol-gasoline blend as the oxygen ratio in blend is 21,62 % in methanol, 50 % in butanol.
2. Methanol which has lower flame temperature compared to gasoline provides better combustion and decreases the NO_x and CO concentration. It was found that the most suitable fuels in terms of CO emission were M50 and B50 fuels.
3. Concentrations of NO_x emissions were decreased depending on the higher alcohol contents.
4. The content of the HC was decreased at higher engine loads but noise level was increased proportionally.

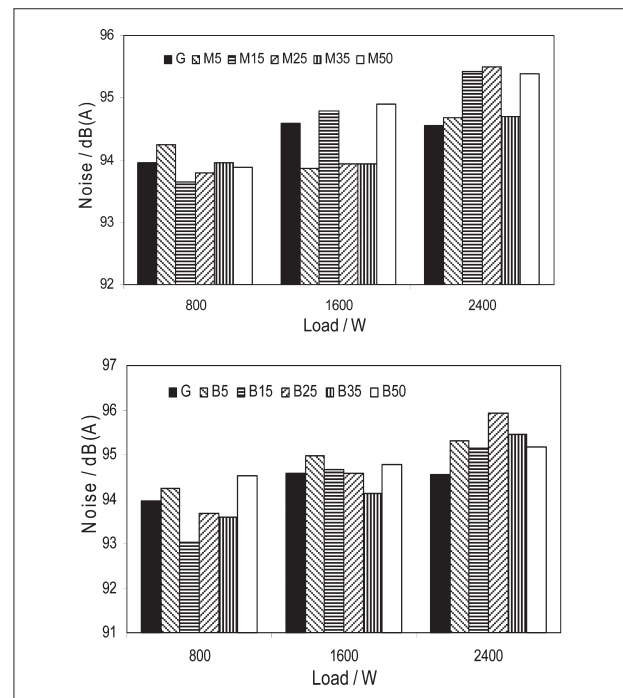

Figure 6 The effect of various engine loads on noise level

REFERENCES

- [1] A.K. Agarwal: Progress in Energy and Combustion Science, 33 (2007), 233-271.
- [2] P.W. McCallum, T.J. Timbario, R.L. Bechtold and E.E. Ecklund: Chemical Engineering Progress, 78 (1982) 8, 52-59.
- [3] B. Winfried: Progress in Energy and Combustion Science, 3 (1997), 139-150.
- [4] S. Kim, B.E. Dale: Biomass & Bio-energy, 28 (2005), 475-89.
- [5] E.E. Wigg: Methanol as a gasoline extender: A Critique, Science, 186 (1974) 4166, 775-780.
- [6] A Technical Assessment of Alcohol Fuels, Alternate Fuels Committee of Engine Manufacturers Association, SAE paper 820261, 1982.
- [7] L.K. Eugene: Applied Combustion, Marcel Dekker Inc., New York, 1993.
- [8] O. Keith and C. Trevor: Automotive Fuels Handbook, SAE Inc., Pennsylvania, 1990.
- [9] F.N. Alasfour: International Journal of Energy Research, 21(1997) 1, 21-30.
- [10] F.N. Alasfour: Applied Thermal Engineering, 18 (1998) 5, 245-256.
- [11] R.W., A.K. Sanyal, A.C. Elrod and R.M. Bata: Journal of Engineering for Gas Turbines and Power, 113 (1991), 377-381.
- [12] AB. Taylor, DP. Mocan, AJ. Bell, NG. Hodgson, IS. Myburgh and JJ. Botha: Gasoline/alcohol blends: exhaust emission, performance and burn-rate in multi-valve production engine, SAE paper 961988, 1996.
- [13] DA. Caffrey PJ., V. Rao: Investigation into the Vehicular Exhaust Emission of High Percentage Ethanol Blends, SAE paper no. 950777, 1995.
- [14] C.W. Wu, R.H. Chen, J.Y. Pu and T.H. Lin: Atmospheric Environment, 38 (2004), 7093-7100.

Note: The professional translator is Serhan Yamacli. Faculty of Technical Education, Mersin University Kartaltepe Mah. Takbas Mevkii. PK.92 Tarsus, Turkey.