

Ivana OŽANIĆ

DVIJE RIMSKE POSUDE S REŠETKOM

TWO ROMAN VESSELS WITH GRIDS

UDK 903.23.02(497.5 Sisak)"652"
903.23.02(497.5 Vinkovci)"652"
Primljeno/Received: 25. 09. 2004.
Prihvaćeno/Accepted: 03.10.2004.

Ivana Ožanić
Odsjek za arheologiju
Filozofski fakultet
Ivana Lučića 3
HR 10 000 Zagreb
iozanic@ffzg.hr

U ovom radu predstavljene su dvije rimske posude s rešetkom pronađene u Vinkovcima i Sisku. Pokušalo se ustanoviti koju su namjenu imale. U literaturi se nazivaju loncima, kadionicama, svjetiljkama, cjediljkama za vino, a najčešće kuhališta za mlijeko. Uz posude s rešetkom prikazuju se i male posude s perforacijom na dnu. Njihova namjena je nepoznata, a otkrivene su u Vinkovcima.

Ključne riječi: Vinkovci, Cibalae, Sisak, Siscia, rimska keramika, posuda s rešetkom, posude s perforacijom na dnu, conditum paradoxum

U ovom radu predstaviti ćemo dvije rimske posude s rešetkom. Pokušat ćemo objasniti njihovu pojavu i iznijeti prijedloge o mogućoj namjeni ovakvih neobičnih posuda.

Prilikom obrade rimskoga keramičkog materijala s lokaliteta Vinkovci-Varteks u Gradskom muzeju Vinkovci zapažena je posuda zanimljivog oblika (sl. 3).¹ Rekonstruirana je na temelju desetak ulomaka koji su nađeni na različitim dubinama i kvadranti-

This work presents two Roman vessels with grids found in Vinkovci and Sisak. An attempt has been made to ascertain their function. In the literature they are referred to as pots, censers, lamps, wine strainers and, most often, milk cookers. Together with the vessels with grids, small vessels with perforations on the bottom are also presented. Their function is unknown, and they were discovered in Vinkovci.

Key words: Vinkovci, Cibalae, Sisak, Siscia, Roman pottery, vessel with grid, vessels with perforations on bottom, conditum paradoxum

In this work two Roman vessels with grids will be presented. An attempt will be made to explain them and proposals will be put forward as to the possible function of these unusual vessels.

During analysis of Roman pottery materials from the Vinkovci-Varteks site in the Vinkovci Municipal Museum, a vessel with an interesting form was observed (Fig. 3).¹ It was reconstructed using ap-

¹ Zahvaljujem dr. sc. Ivani Iskri-Janošić i Anti Rendiću-Miočeviću na ustupljenom materijalu, Domagoju Perkiću koji je restaurirao posudu iz Vinkovaca te Marti Perkić i Miljenki Galić na crtežima.

¹ I would like to thank Ivana Iskra-Janošić, Ph.D. and Ante Rendić-Miočević for making the materials available, Domagoj Perkić, who restored the vessel from Vinkovci and Marta Perkić and Miljenka Galić for their drawings.

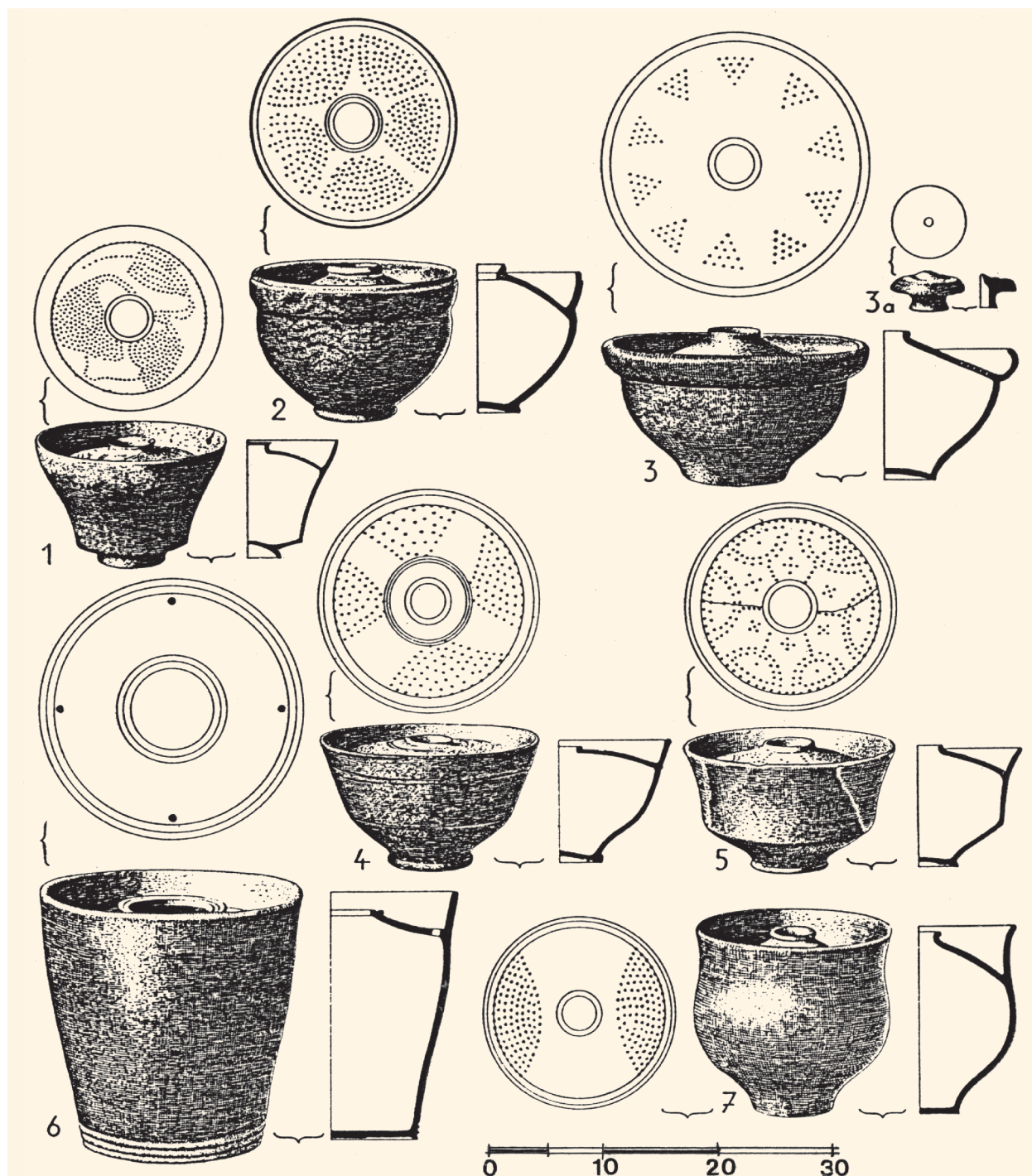

Slika 1. "Kuhala za mlijeko" (Bersu 1930: T 32: 1; Behrens 1952: 110).

1. Posuda od bijele gline; rupicama je izraden ukras od triju srcolikih listića (Bonn, Mus. Bonn inv. br. 30658, odljevak 36397 u RGZ – Mus. Meinz).
2. Smečkasta posuda s tamnosmeđim valovnicama (Gering, Mus. Bonn inv. br. 24174a, odljevak 36396 u RGZ – Mus. Meinz).
3. Posuda od sivoplave gline s pokretnim umetkom od istog materijala (Nymwegen, Rijksmus. Kam, Nymwegen, odljevak 36389 u RGZ – Mus. Meinz).
4. Posuda premazana crvenom bojom (Hedesheim Alertumsmus. Mainz, odljevak 1380 u RGZ – Mus. Meinz).
5. Posuda premazana crvenom bojom (Friedberg, Mus. Friedberg).
6. Smedecrvena posuda s četiri veće rupe (Weisenau, Alertumsmus. Mainz, odljevak 22 605 u RGZ – Mus. Meinz).
7. Crna posuda (Trier, odljevak 23255 u RGZ – Mus. Meinz).

Figure 1. "Milk cooker" (Bersu 1930: T 32: 1; Behrens 1952: 110)

1. White clay vessel; holes form decoration of three heart-shaped leaves (Bonn, Mus. Bonn inv. no. 30658, casting 36397 in RGZ – Mus. Meinz).
2. Brownish vessel with dark brown waves (Gering, Mus. Bonn inv. no. 24174a, casting 36396 in RGZ – Mus. Meinz).
3. Gray-blue clay vessel with movable inserted piece made of same material (Nymwegen, Rijksmus. Kam, Nymwegen, casting 36389 in RGZ – Mus. Meinz).
4. Vessel covered with red paint (Hedesheim Alertumsmus. Mainz, casting 1380 in RGZ – Mus. Meinz).
5. Vessel covered with red paint (Friedberg, Mus. Friedberg).
6. Brown-red vessel with four large holes (Weisenau, Alertumsmus. Mainz, casting 22 605 in RGZ – Mus. Meinz).
7. Black vessel (Trier, casting 23255 in RGZ – Mus. Meinz).

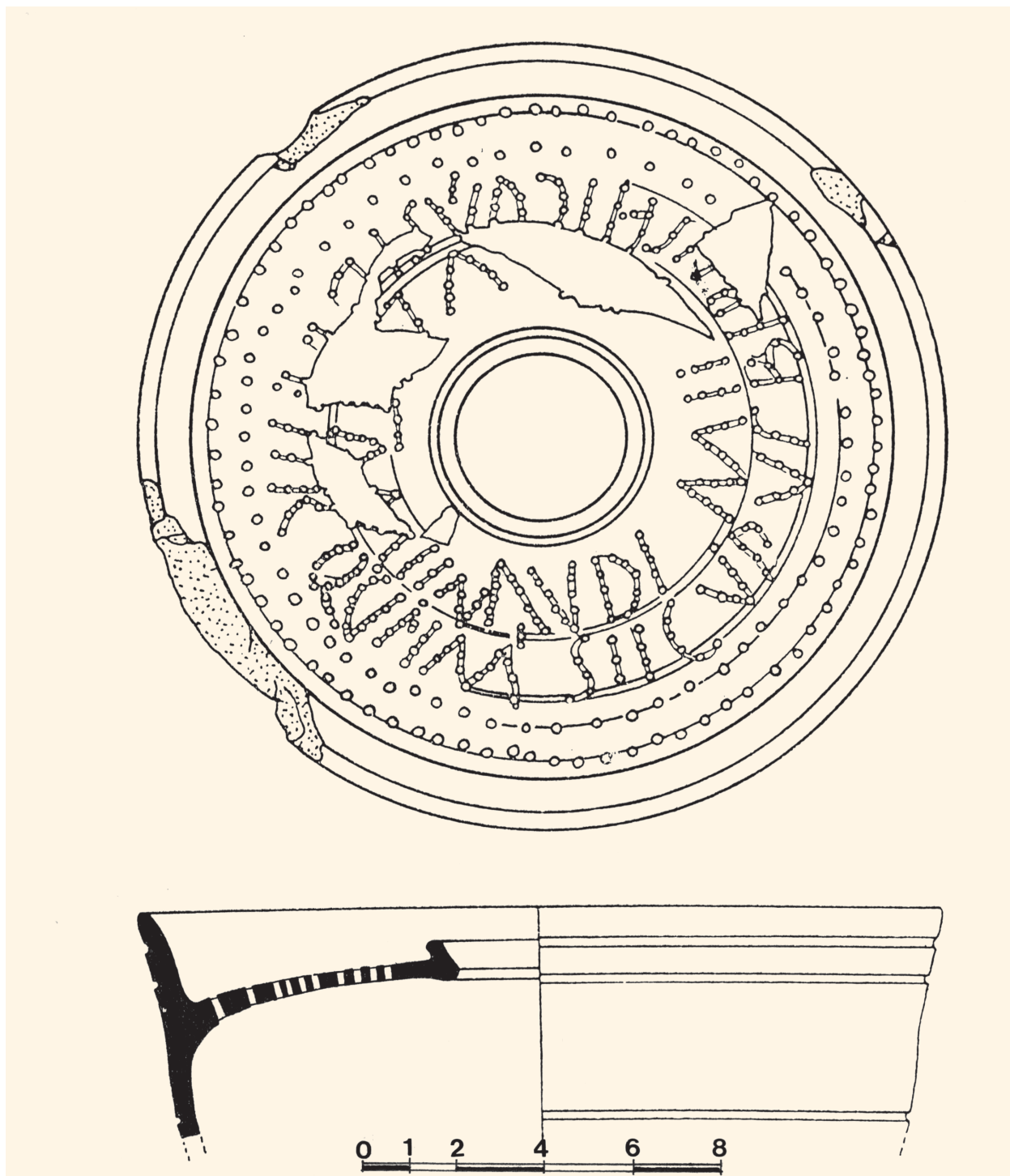

Slika 2. Posuda za cijedenje vina s natpisom Audi me ude tamen quem secu(n)dus bibes hic vasi defer (Nuber 1969–1970: 70–75)
Figure 2. Vessel for straining wine bearing inscription Audi me ude tamen quem secu(n)dus bibes hic vasi defer (Nuber 1969–1970: 70–75)

ma prilikom istraživanja lokaliteta Vinkovci-Varteks 1982. godine (Iskra-Janošić 1995: 8; 2001: 68; Ožanić

proximately a dozen fragments found at various depths and quadrants during research at the Vinko-

2004a: 14, 118, T 60: 19).² Posuda je izrađena od crvenkaste gline i prevučena crvenim premazom. Ima duguljasto, blago zaobljeno tijelo na koje je okomito postavljen vrat. Prijelaz iz tijela u vrat naglašen je dvjema kanelurama, a druge dvije nalaze se uz sam rub posude. Oko 2,5 cm ispod ruba posude, s unutrašnje strane, sačuvan je dio ravne rešetke. Na temelju usporedbe sa sličnim posudama možemo pretpostaviti da je imala šest rupa, a na sredini veći otvor (Beherns 1952: 110–111). Visoka je 20 cm, promjer ruba joj je 19 cm, a promjer dna 9 cm. Sačuvane rupe na rešetki imaju prosječan promjer od 1,5 cm. Slična, ali potpuno sačuvana posuda iz Siska čuva se u Arheološkom muzeju u Zagrebu (Sl. 4). Posuda je crno-smeđe boje s krupnijim primjesama kvarca i pljeve. Tijelo posude je blago zaobljeno, a vrat je ukošen. Rešetka se nalazi 1 cm ispod ruba posude s unutrašnje strane i ukošena je. Na rešetki se nalazi osam rupa kojima je promjer 0,8 cm. Visoka je 10 cm, promjer ruba ruba je 14,5 cm, promjer dna 12,5 cm, a promjer središnje rupe 5,5 cm (Ožanić 2004a: 118, sl. 11).³ Rimske posude s rešetkom nisu, međutim, bile rijetkost. Iz literature doznajemo da su se slične posude izrađivale u keramičkim radionicama diljem carstva – kako u onima u kojima se proizvodila *terra sigillata* tako i u radionicama koje su proizvodile keramiku za svakodnevnu upotrebu (Bersu 1930: T 32.1; Beherns 1952: 110–111; Conspectus: 140; Atlante I: 50, T XXIII: 2, 3).

Zahvaljujući upravo ovim poznatim primjerima, i vinkovačku i sisačku posudu s rešetkom možemo smatrati proizvodom lokalnih panonskih radionica. Obje posude možemo datirati u 2. stoljeće.

Veći problem predstavlja pitanje namjene ovakvih posuda. Nazivalo ih se loncima, kadionicama, svjetiljkama, a najčešće kahalima za mlijeko (Beherns 1952: 110; Nuber 1969–1970: 70–73; Clauss 2001: 128, sl. 64).

Najviše objavljenih posuda s rešetkom nalazimo kod Gustava Behernsa koji ih naziva kahalima za mlijeko (*Milchkocher*) i okvirno datira od 1. do 2. st. (Beherns 1952: 110) (Sl. 1). Beherns je sastavio popis od šesnaest posuda s različitih lokaliteta u Germaniji te dviju iz Britanije.⁴ Na temelju tog opširnog

vci-Varteks site in 1982 (Iskra-Janošić 1995: 8; 2001: 68; Ožanić 2004a: 14, 118, T 60: 19).² The vessel is made of reddish clay and covered with a red paste. It has a long, slightly rounded body with a vertically-set neck. The transition from the body to the neck is highlighted with two canelures, while the other two are on the very rim of the vessel. Approximately 2.5 cm under the vessel's rim, from the inside, a part of the flat grid has been preserved. On the basis of comparisons with similar vessels, we can assume that it had six holes, and a larger opening in the middle (Beherns 1952: 110–111). It is 20 cm high, the diameter of its rim is 19 cm, while the diameter of the bottom is 9 cm. The preserved holes on the grid have an average diameter of 1.5 cm.

A similar, but completely preserved vessel from Sisak is held in the Archeological Museum in Zagreb (Fig. 4). The vessel is black-brown in color, made of material containing larger quantities of quartz and chaff. The body of the vessel is slightly rounded, while the neck is slanted. The grid is located 1 cm below the vessel's rim on the inside and it is slanted. There are eight holes on the grid, each with a diameter of 0.8 cm. It is 10 cm high, the diameter of the rim is 14.5 cm, the diameter of the bottom is 12.5 cm, and the diameter of the central hole is 5.5 cm (Ožanić 2004a: 118, Fig. 11).³

Roman vessels with grids were not, however, rare. The literature indicates that similar vessels were made in ceramic workshops throughout the Empire—both in those where *terra sigillata* was produced and in workshops in which pottery for everyday use was made (Bersu 1930: T 32.1; Beherns 1952: 110–111; Conspectus: 140; Atlante I: 50, T XXIII: 2, 3).

Thanks precisely to these known examples, both the Vinkovci and Sisak vessels with grids can be considered products of local Pannonian workshops. Both vessels can be dated to the second century.

A greater problem is the question of their function. They have been called pots, censers, lamps and, most often, milk cookers (Beherns 1952: 110; Nuber 1969–1970: 70–73; Clauss 2001: 128, Fig. 64).

Most of the published vessels with grids can be found in the work of Gustav Beherns, who called them milk cookers (*Milchkocher*) and generally dated them to the first to second century – Fig. 1 (Beherns 1952: 110). Beherns compiled a list of sixteen vessels from various sites in Germania and two

² Posuda se čuva u Gradskom muzeju Vinkovci GMV A – 1852.

³ Jedini podatak o mjestu nalaza ove posude nalazimo na signaturi nalijepljenoj na posudi koja glasi "Poklonio Tkalčić, iskapano u Sisku".

⁴ Uz sedam lokaliteta koji su navedeni uz crtež navodi još sljedeće lokalitete: Neuss (crna posuda s nezavršenim rupama, loše pečena); Bingen (crna posuda); Strassburg (crveno-smeđa posuda); Kastell Neuenheim; Frankfurt a. M.; Köln, Aachener Strasse; Kastel Pfunz; Niederbieber; Burgheim. Lokaliteti s nalazima posuda s rešetkom u Britaniji su Litlington (bijela fina keramika tankih stjenki, rupicama je ispisano ime *INDV[L]CIVS*) i Silchester.

² The vessel is kept at the Vinkovci Town Museum, GMV A – 1852.

³ The only data on the location at which this vessel was found is on the tag on it reading "Donated by Tkalčić, excavated in Sisak".

popisa zaključujemo da ove posude nisu rijetkost. Glina koja je korištena za njihovu izradu različite je kvalitete i može se reći da nema pravila. Rupe na rešetki probijane su na razne načine i ponekad čine vegetabilni ili geometrijski ukras. Posuda otkrivena u Litlingtonu (Britanija) ima rupicama ispisano *INDV[L]CIVS*. Posuda na slici 1,3 ima sačuvan i pokretni umetak (Sl. 1, 3a) te nas upućuje na zaključak da se većina ovih posuda mogla zatvoriti. Zanimljivo je i to što je umetak ove posude također perforiran po sredini (Beherns 1952: 110–111).

Popis koji je sastavio Beherns možemo proširiti još nekim primjerima. U Magdalensbergu nađena je posuda cilindričnog oblika koja također ima rešetku (Conspectus: 51.1.1). Datira se od augustovog do flavijevskog vremena i pripada oblicima *terrae sigillatae* etruske ili padanske provinijencije (Conspectus: 140).

U oblicima rimske afričke keramike nalazi se nekoliko tipova posuda koje imaju rešetku (Atlante I: 50, T XXIII: 2, 3). Riječ je o oblicima Hayes 124 i Lamboglia 16 *bis*. Visina posuda kreće se od 5,4 cm do 6,9 cm, a promjer im je od 8,6 cm do 9,6 cm. Oblik Hayes 124 uvjetno se datira od flavijevsko-trajanskog doba. Neki primjeri nađeni su u slojevima iz druge polovice 2. st. (Ostia). Oblik Lamboglia 16 *bis* datira se u 2. st. Ovi oblici dokumentirani su u afričkoj sigilati A¹, u istočnoj sigilati B te u lokalnoj produkciji u Korintu (Atlante I: 50, T XXIII: 2, 3). Zbog oblika uspoređuju se i s oblikom *terrae sigillatae* Ritterling 13 (Conspectus: 51.3.1) koji je služio kao tintarnica. Kao proizvod afričke sigilate A¹ javljaju se i tzv. *gutusi* od kojih neki također imaju rešetku (Atlante I: 51, T XXIII: 4, 5, 10).

Nasreću, jednoj posudi s rešetkom otkrivenoj na lokalitetu Nida – Heddernheim definitivno je ustanovljena namjena. Služila je za procjeđivanje vina (Nuber 1969–1970: 70–73). Naime dio rešetke izrađen je kao natpis koji glasi: *Audi me ude tamen quem secu(n)dus bibes hic vasi defer* (Sl. 2).⁵

Ako želimo posudu iz Heddernheimusa usporediti s posudama iz Siska i Vinkovaca, moramo se osvrnuti na sastojke koji su se dodavali u vino i procjeđivali. Najpoznatije vino sa začinima je *conditum paradoxum* u koje se stavljaju med, papar, lovor, šafran te meso, sjemenke datulja pa čak i ugljen. *Conditum paradoxum* radio se tako da se prvo napravila manja količina ovako začinjenog vina, pustila se da odstoji i kasnije se dodavala u veću posudu (Apicije: 1, 1; Ožanić 2004b: 37–38). Postoje razne vrste metalnih i keramičkih cjediljki upotrebljivanih u

from Britannia.⁴ Based on this extensive list we can conclude that these vessels are not rarities. The clay used to make them has a different quality, so one can say that there is no standard here. The holes on the grid were made in various ways, and sometimes they form vegetable or geometric decorations. The vessel discovered in Litlington (Britannia) features the name *INDV[L]CIVS* written with holes. The vessel on Fig. 1.3 has a preserved and movable inserted piece (Fig. 1.3a) and indicates the conclusion that most of these vessels could have been closed. It is interesting that inserted piece of this vessels is also perforated down the middle (Beherns 1952: 110–111).

The list compiled by Beherns can be expanded with several other examples. A cylindrically-formed vessel was found in Magdalensberg that also had a grid (Conspectus: 51.1.1). It dates back to some point during the Augustan to Flavian era and belongs to the *terrae sigillatae* forms of Etruscan or Padanian provenance (Conspectus: 140).

In Roman-era African pottery, there are several types of vessels with grids (Atlante I: 50, T XXIII: 2, 3). These are the Hayes 124 and Lamboglia 16 *bis* forms. The height of the vessels runs from 5.4 cm to 6.9 cm, while their diameter is 8.6 cm to 9.6 cm. The Hayes 124 form conditionally dates to the Flavian/Trajanic era. Some examples have been found in the layers from the second half of the second century (Ostia). The Lamboglia 16 *bis* form dates to the second century. These forms have been documented in African sigillata A¹, in the eastern sigillata B and in local production in Corinth (Atlante I: 50, T XXIII: 2, 3). Due to the form, they have also been compared to the *terrae sigillatae* Ritterling 13 form (Conspectus: 51.3.1) which served as an inkpot. The so-called *gutus* also appears as a product of African sigillata A¹, of which some also have a grid (Atlante I: 51, T XXIII: 4, 5, 10).

Fortunately, the function of one vessel with grid found at the Nida-Heddernheim site has been definitely ascertained. It served to strain wine (Nuber 1969–1970: 70–73). Part of the grid was crafted as an inscription that reads: *Audi me ude tamen quem secu(n)dus bibes hic vasi defer* (Fig. 2).⁵

⁴ Besides the seven sites cited with the drawing, the following sites are also mentioned: Neuss (black vessel with incomplete holes, poorly baked); Bingen (black vessel); Strassburg (red-brown vessel); Kastell Neuenheim; Frankfurt a. M.; Cologne, Aachener Strasse; Kastel Pfundz; Niederbieber; Burgheim. Sites with finds of vessels with grids in Britannia are Litlington (white fine ceramic with thin sides, holes spelling the name *INDV[L]CIVS*) and Silchester.

⁵ Loosely translated: *Hear me and soak in time that which you shall then drink and then offer from the vessel.*

⁵ U slobodnom prijevodu: *Čuj me i navlaži u pravo vrijeme to što ćeš zatim piti i tada ponudi iz posude.*

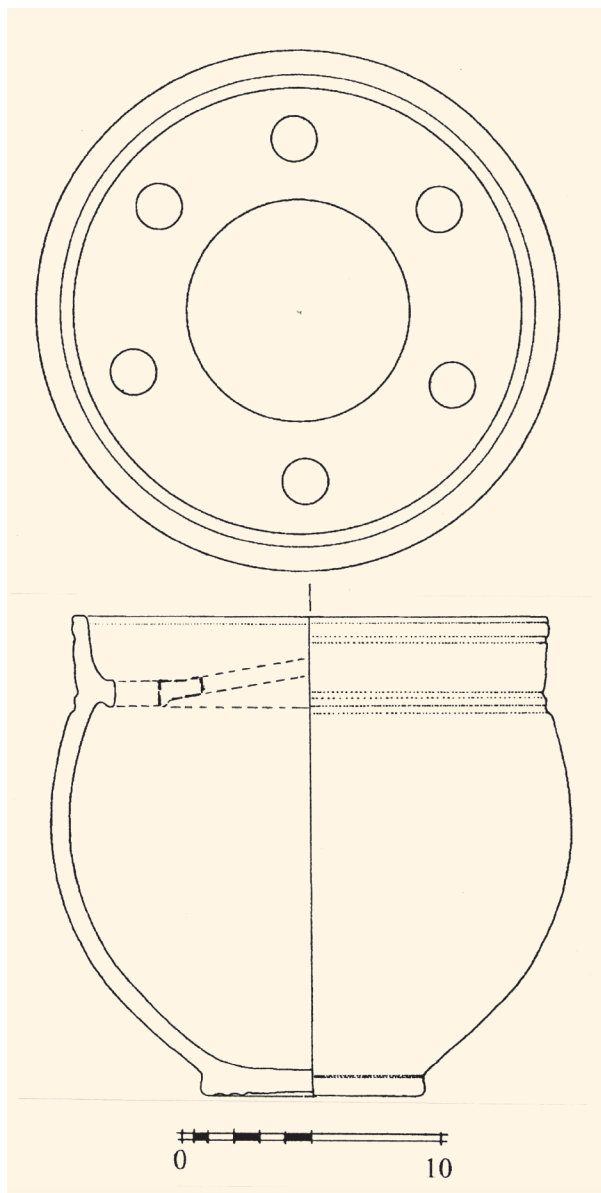

Slika 3. Posuda s rešetkom iz Vinkovaca (Ožanić 2004a: T 60: 19)

- glina: tvrda, s malo primjesa, crvenkasto žuta, 2.5 YR 6/8 (reddish yellow); premaz: na vanjskoj i unutarnjoj stijenci, svijetlocrven, 2.5 YR 6/6 (light red), iznutra su tragovi gorenja; visina: 20 cm, promjer ruba: 19 cm, promjer dna: 9 cm, debljina stijenke: 0,9 cm, inv. br. GMV – 1852, mjesto nalaza: Vinkovci-Varteks 1982.

Figure 3. Vessel with grid from Vinkovci (Ožanić 2004a: T 60: 19)

- clay: hard, with a small additional materials in composition, reddish yellow, 2.5 YR 6/8; paste: on external and internal sides, light red, 2.5 YR 6/6, inside has traces of burning; height: 20 cm, rim diameter: 19 cm, bottom diameter: 9 cm, width of sides: 0.9 cm, inv. no. GMV – 1852, found at site: Vinkovci-Varteks 1982.

antici koje su mogle služiti i za procjeđivanje vina. Može se pretpostaviti da je i većina posuda koje spominje Beherns služila u tu svrhu. Dakle, manja

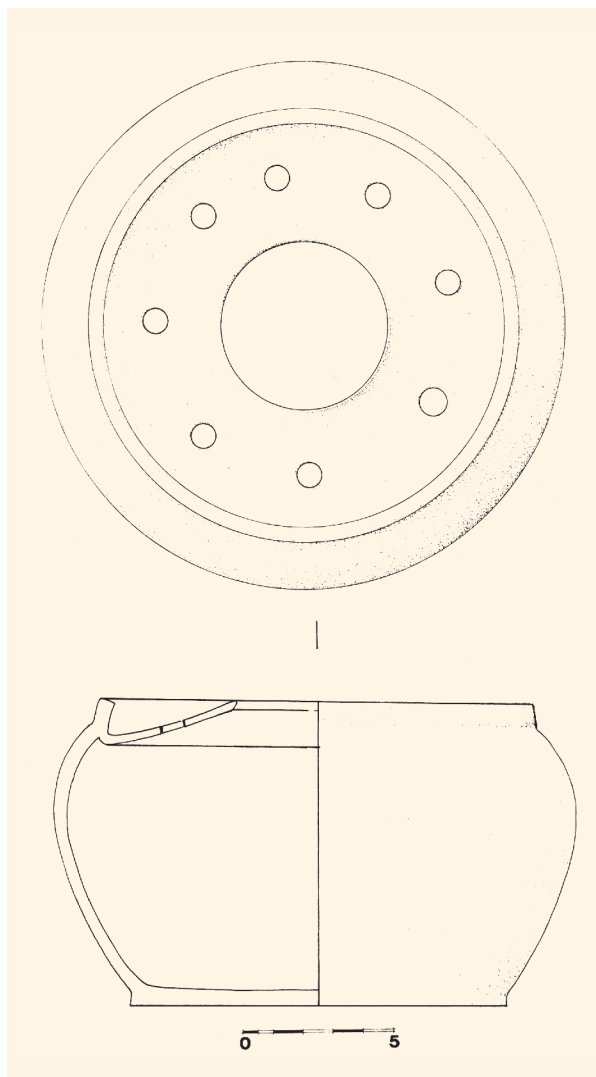

Slika 4. Posuda s rešetkom iz Siska (Ožanić 2004a: sl. 11)

- glina: crno-smeđe boje s krupnijim primjesama; visina: 10 cm, promjer ruba: 14,5 cm, promjer dna: 12,5 cm, debljina stijenke: 0,5 cm, inv. br. AMZ 28, mjesto nalaza: Sisak; poklon V. Tkalčića

Figure 4. Vessel with grid from Sisak (Ožanić 2004a: figure 11)

- clay: black-brown with larger additional materials in composition; height: 10 cm, rim diameter: 14.5 cm, bottom diameter: 12.5 cm, width of sides: 0.5 cm, inv. no. AMZ 28, found at site: Sisak; donation from V. Tkalčić

If we wish to compare the vessel from Heddernheim with the vessels from Sisak and Vinkovci, we have to consider the ingredients that were placed in wine and then strained. The best known spiced wine was *conditum paradoxum*, in which honey, pepper, laurel leaf, saffron and meat, date seeds and even coal were added. *Conditum paradoxum* was made such that first a smaller quantity of wine so spiced was prepared and allowed to sit and then later added to

količina *condituma paradoxuma* odstajala bi u takvoj posudi i ulila se u veću količinu vina prilikom posluživanja. U ovoj se posudi moglo izmiješati i vino s vodom ili snijegom, što je bilo popularno kod Rimljana (Ožanić 2004b: 36). Na lokalitetu Neuss, u keramičarskom radioničkom centru, otkriven je ulomak vrča (Haltern tip 54, Bruckner tip 6) datiran u 1. st. koji je imao rešetku na izljevu, a služio je za posluživanje vina sa začinima (Bruckner 1975: 86, T 39: 21–22).

Potaknuti pokretnim umetkom na slici 1,3a osvrnut ćemo se na još jedan tip perforiranih posuda koje su nađene u Vinkovcima (Ožanić 2004a: T 88: 2, 3, 4, 5, 6, 7, 8) (Sl. 5). Riječ je o sedam primjeraka malih zdjelica nađenih na lokalitetu Vinkovci-Komercijalna banka koji je istraživao 1973. godine, a nalazi se uz lokalitet Vinkovci-Varteks (Ožanić 2004a: 16). To su posude poluloptastog ili blago bikoničnog oblika visine od 2,5 cm do 4,8 cm. Specifičnost koju zapažamo na čitavim primjercima perforacija je na dnu posuda. Sličan oblik posuda malih dimenzija, bez perforacije na dnu, dokumentiran je u Singidnumu (Nikolić-Đorđević 2000: 181–182). S. Nikolić-Đorđević smatra da su te posude mogle biti dječje igračke ili su služile za začine i namirnice konzumirane u manjim količinama. Datira ih od 2. do 3. st. Kalup za zdjelice od keramike tankih stijenki iz Sirmija također ima perforaciju na dnu posude. Pretpostavlja se da su takve perforacije služile za lakše postavljanje kalupa na lončarsko kolo (Bruckner 1981: 75, T 46: 8). Zbog malih dimenzija male posude s rupom na dnu ne smatramo kalupom, a upravo zbog perforacije odbacujemo pretpostavku da su bile igračke ili posude za začine. U inventarnoj knjizi Gradskog muzeja Vinkovci ove su posude inventirane kao zatvarači. Bilo bi pretenciozno smatrati da su ove posudice služile za zatvaranje posuda s rešetkom, no po svemu sudeći mogle su biti korišene uz neke druge posude. Perforacija je mogla služiti za kontroliranje količine tekućine koja se ulijeva u posudu. U ovom trenutku pitanje upotrebe ovih malih zdjelica moramo ostaviti otvorenim.

Glavni cilj ovoga rada bio je skrenuti pažnju na posude s rešetkom i postaviti pitanje njihove namjene. Samo jedna takva posuda, i to ona iz Heddernheim, ima natpis koji nam eksplicitno govori da je služila za posluživanje vina. Behernsovo mišljenje da su ove posude služile kao kuhala za mlijeko ne čini nam se uvjerljivim, premda se ne može isključiti ni ta mogućnost.

Razmatrajući namjenu spomenutih posuda moramo istaknuti da posuda s rešetkom iz Vinkovaca ima važan detalj. Naime u unutrašnjosti nailazimo na tragove gorenja. Već smo spomenuli da su se ponekad ovakve posude smatrale kadionicama (Claus

a larger vessel (Apicije: 1, 1; Ožanić 2004b: 37–38). There are various types of metal and ceramic grids used in Classical Antiquity that can serve to strain wine. It can be assumed that most of the vessels mentioned by Beherns served this purpose. Thus, a smaller quantity of *conditum paradoxum* would remain in such a vessel and then be poured into a larger quantity of wine prior to serving. Wine in this vessel could be mixed with water or snow, which was popular with the Romans (Ožanić 2004b: 36). At the Neuss site, the fragment of a pitcher (Haltern type 54, Bruckner type 6) was discovered in the ceramic workshop center and dated to the first century. It had a grid at the pouring rim, and it was used to serve spiced wine (Bruckner 1975: 86, T 39: 21–22).

Prompted by the movable insert on Fig. 1.3a, one other type of perforated vessel found in Vinkovci will be examined – Fig. 5 (Ožanić 2004a: T 88: 2, 3, 4, 5, 6, 7, 8). These are seven examples of small bowls found at the Vinkovci-Komercijalna banka site that was researched in 1973, and which is located next to the Vinkovci-Varteks site (Ožanić 2004a: 16). These semi-spherical or slightly biconical bowls are 2.5 cm to 4.8 cm high. The specific aspect that is notable on the whole examples is the perforation on the bottoms of the bowls. A similar vessel form of smaller dimensions, without the bottom perforation, was documented in Singidnum (Nikolić-Đorđević 2000: 181–182). S. Nikolić-Đorđević believes that these vessels could have been children's toys or containers for spices or food consumed in smaller quantities. They have been dated to the second to third centuries. The mold for bowls with thin ceramic sides from Sirmium also has perforations on the bottom. It has been assumed that such perforations served to make it easier to place the mold on the pottery wheel (Bruckner 1981: 75, T 46: 8). Due to its small dimensions, the small vessel with the hole in the bottom is not considered a mold, and precisely due to the perforations the assumption that they were toys or spice containers has been rejected. The Vinkovci Municipal Museum's inventory register lists these vessels as lids. It would be pretentious to believe that these small vessels were used to close vessels with grids, but by all indications they were used with some other vessels. The perforations could have served to control the quantity of liquid poured into the vessel. At this moment the use of these small bowls must remain an open question.

The principal objective of this paper is to turn attention to the vessels with grids and pose the question of their function. Only one such vessel, the one from Heddernheim, bears an inscription that explicitly states that it was used to serve wine. Beherns' view

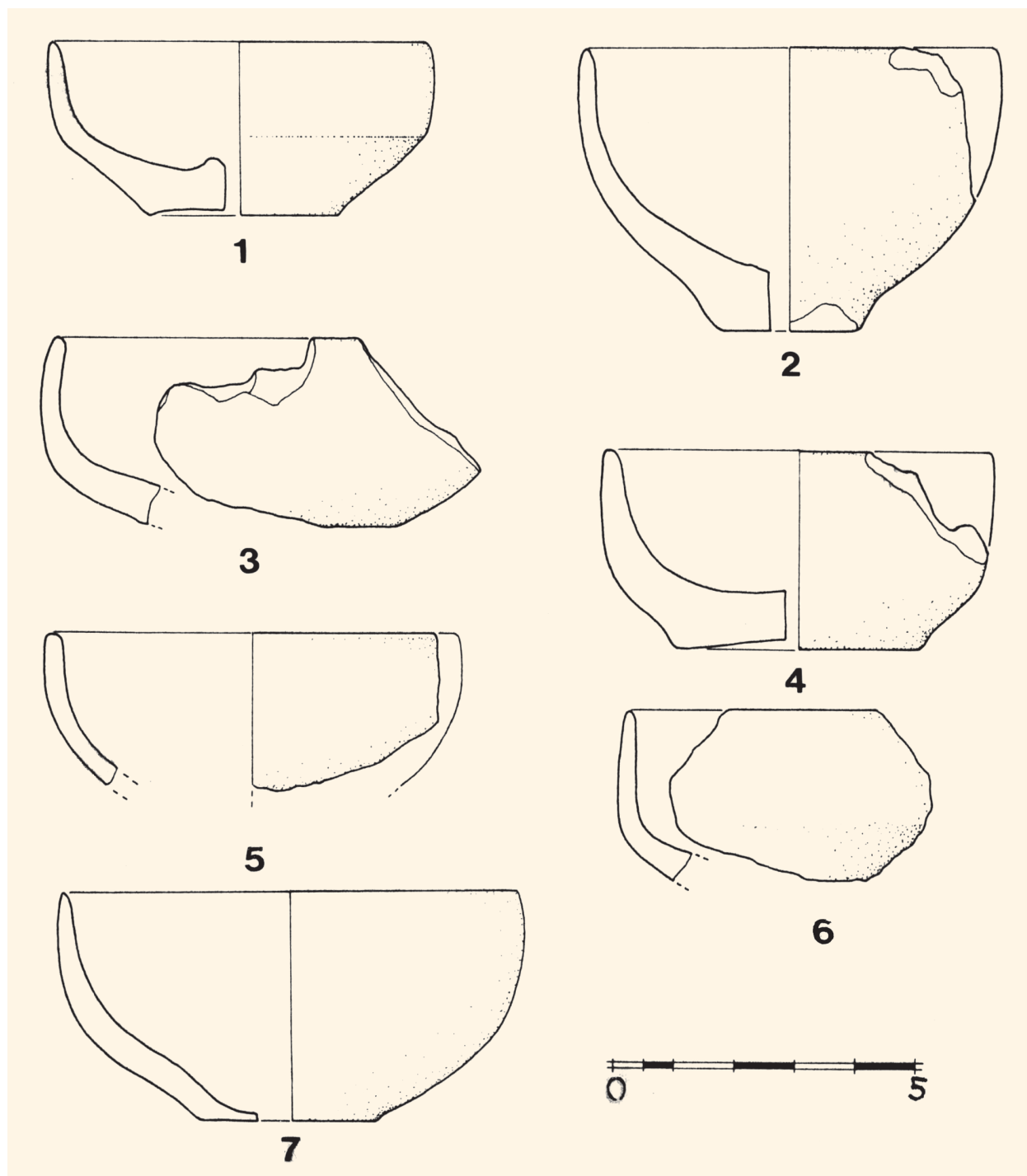

Slika 5. Posude malih dimenzija s perforacijom na dnu (Ožanić 2004a: T 88: 2, 3, 4, 5, 6, 7, 8)

1. Posuda malih dimenzija i bikoničnoga tijela s perforiranim ravnim dnom – glina: tvrda s krupnim, bijelim primjesama, svijetlosmeđa, 7.5 YR 6/4 (light brown); visina: 2,8 cm, promjer ruba: 6,5 cm, promjer dna: 3,5 cm, debljina stijenki: 0,3 cm; inv. br.: GMVA – 3574, mjesto nalaza: Vinkovci-Komercijalna banka, datacija: 2.–3. st. 2. Posuda malih dimenzija i bikoničnog tijela s perforiranim ravnim dnom – glina: mekana s primjesama, svijetlocrvena, 2.5 YR 6/6 (light red); visina: 4,8 cm, promjer ruba: 7 cm, promjer dna: 2,5 cm, debljina stijenke: 0,4 cm; mjesto nalaza: Vinkovci-Komercijalna banka II 2,10 – 2,10, datacija: 2.–3. st. 3. Posuda malih dimenzija, bikoničnog tijela – glina: svijetlosmeđa, malo primjesa, 7.5 YR 6/4 (light brown); visina: 3 cm, promjer ruba: 7,5 cm, debljina stijenki: 0,5 cm; mjesto nalaza: Vinkovci-Komercijalna banka II 2,60–3,10, datacija: 2.–3. st. 4. Posuda malih dimenzija i ravnih stijenki s perforiranim ravnim dnom – glina: mekana, sitne primjese, svijetlosmeđa, 7.5 YR 6/4 (light brown), visina: 3,4 cm, promjer ruba: 5,5 cm, promjer dna: 4 cm, debljina stijenki: 0,7 cm; mjesto nalaza: Vinkovci-Komercijalna banka I 2,10–3,30, datacija: 2.–3. st. 5. Posuda malih dimenzija i bikoničnog tijela s perforiranim ravnim dnom – glina: mekana sa sitnim primjesama, ružičasta, 5 YR 7/4 (pink); visina: 2,5 cm, promjer ruba: 7 cm, debljina stijenki: 0,4 cm; mjesto nalaza: Vinkovci-Komercijalna banka I 3,10–3,30, datacija: 2.–3. st. 6. Posuda malih dimenzija i ravnih stijenki; ulomak stijenke i ruba – glina: mekana, sa sitnim primjesama, žuta, 10 YR 7/6 (yellow), visina: 2,8 cm, promjer ruba: 7 cm, debljina stijenki: 0,4 cm; mjesto nalaza: Vinkovci-Komercijalna banka I 1,00–2,00, datacija: 2.–3. st. 7. Posuda malih dimenzija, ravnih stijenki; ulomak stijenke i ruba – glina: mekana sa sitnim primjesama, 10 YR 7/6 (yellow); visina: 2,8 cm, debljina stijenki: 0,4 cm; mjesto

2001: 128, sl. 64). Stoga zbog tragova gorenja ovu vinkovačku posudu možemo smatrati kadionicom (Claus 2001: 128, sl. 64).

Sisačka posuda više nalikuje posudama otkrivenim u Germaniji (Behrens 1952: 110–111). Nema vidljivih tragova gorenja kao kod vinkovačke posude, niža je od vinkovačke, a i rupe na rešetki su manje. Stoga moramo konstatirati da je zasad nejasno u koje se svrhe upotrebljavala sisačka posuda s rešetkom.

that these vessels were used to cook milk is not convincing, although this possibility cannot be excluded.

In considering the function of these vessels, it must be stressed that the vessel with grid from Vinkovci bears an important detail: there are traces of burning on the inside. It has already been noted that these vessels were sometimes considered censers (Claus 2001: 128, Fig. 64). Therefore, due to the traces of burning, this Vinkovci vessel can be considered a censer (Claus 2001: 128, Fig. 64).

The Sisak vessel bears greater similarity to the vessels discovered in Germania (Behrens 1952: 110–111). There are no visible traces of burning as with the Vinkovci vessel, it is lower than its Vinkovci counterpart, and the holes on the grid are smaller. Therefore, the purpose of the Sisak vessel with grid is still unclear for now.

nalaza: Vinkovci-Komercijalna banka, datacija: 2.–3. st. 8. Posuda malih dimenzija i bikoničnog tijela s perforiranim ravnim dnom – glina: mekana, s primjesama, ružičasta, 7.5 YR 7/4 (pink); visina: 3,8 cm, promjer ruba: 7,5 cm, promjer dna: 3 cm, debljina stijenke 0,5 cm; mjesto nalaza: Vinkovci-Komercijalna banka V 2,10–2,40, datacija: 2.–3. st.

Figure 5. Small vessels with perforation on bottom (Ožanić 2004a: T 88: 2, 3, 4, 5, 6, 7, 8)

1. Small vessel with biconical body and perforated flat bottom – clay: hard with large, white additional materials in composition, light brown, 7.5 YR 6/4; height: 2.8 cm, rim diameter: 6.5 cm, bottom diameter: 3.5 cm, width of sides: 0.3 cm; inv. no.: GMV A – 3574, found at site: Vinkovci-Komercijalna banka, dated: 2nd–3rd cent. 2. Small vessel with biconical body and perforated flat bottom – clay: soft with additional materials in composition, light red, 2.5 YR 6/6 (light red); height: 4.8 cm, rim diameter: 7 cm, bottom diameter: 2.5 cm, width of sides: 0.4 cm; found at site: Vinkovci-Komercijalna banka, dated: 2nd–3rd cent. 3. Small vessel with biconical body – clay: light brown, little additional materials in composition, 7.5 YR 6/4; height: 3 cm, rim diameter: 7.5 cm, width of sides: 0.5 cm; found at site: Vinkovci-Komercijalna banka, dated: 2nd–3rd cent. 4. Small vessel with flat sides and perforated flat bottom – clay: soft, tiny additional materials in composition, light brown, 7.5 YR 6/4, height: 3.4 cm, rim diameter: 5.5 cm, bottom diameter: 4 cm, width of sides: 0.7 cm; found at site: Vinkovci-Komercijalna banka, dated: 2nd–3rd cent. 5. Small vessel with biconical body and perforated flat bottom – clay: soft with tiny additional materials in composition, pink, 5 YR 7/4; height: 2.5 cm, rim diameter: 7 cm, width of sides: 0.4 cm; found at site: Vinkovci-Komercijalna banka, dated: 2nd–3rd cent. 6. Small vessel with flat sides; fragment of side and rim – clay: soft with tiny additional materials in composition, yellow, 10 YR 7/6, height: 2.8 cm, rim diameter: 7 cm, width of sides: 0.4 cm; found at site: Vinkovci-Komercijalna banka, dated: 2nd–3rd cent. 7. Small vessel with flat sides; fragment of side and rim – clay: soft with additional materials in composition, 10 YR 7/6, yellow; height: 2.8 cm, width of sides: 0.4 cm; found at site: Vinkovci-Komercijalna banka, dated: 2nd–3rd cent. 8. Small vessel with biconical body and perforated flat bottom – clay: soft with additional materials in composition, pink, 7.5 YR 7/4; height: 3.8 cm, rim diameter: 7.5 cm, bottom diameter: 3 cm, width of sides 0.5 cm; found at site: Vinkovci-Komercijalna banka, dated: 2nd–3rd cent.

KRATICE / ABBREVIATIONS

Apicije 1989	S. Slapšak: <i>De re coquinaria APICII</i> , Zagreb, 1989.
Atlante I	Enciclopedia dell'arte antica, Atlante delle forme ceramiche, vol.1, Roma 1981.
Conspectus 1990	E. Ettlinger, B. Hedinger, B. Hoffmann, Ph. M. Kernick, G. Pucci, K. Roth-Rubi, G. Schneider, S. von Schnurbein, C. M. Wells, S. Zablecky-Scheffenecker (eds): <i>Conspectus formarum terrae sigillatae italico modo confectae (Materialien zur Römisch-germanischen Keramik 10)</i> , Bonn, 1990.
GOMHV	Godišnjak Ogranka Matice hrvatske Vinkovci, Vinkovci
RCRF	Rei cretarie romanae fautores

LITERATURA / BIBLIOGRAPHY

Bersu 1930	M. Bersu: "Kunstgewerbe und Handwerk", <i>Germania Romana</i> ² 5, 1930, 5–31.
Beherns 1952	G. Beherns: "Römische Milchkocher", <i>Germania</i> 30, 1952, 110–111.
Bruckner 1975	A. Bruckner: "Gebrauchskeramik aus zwei Augustischen Töpferöfen von Neuss", <i>Novesium</i> 4, 1975, 77–119.
Bruckner 1981	O. Bruckner: <i>Rimska keramika na jugoslovenskom dijelu provincije Panonije</i> , Beograd, 1981.
Clauss 2001	M. Clauss: <i>The Roman Cult of Mithras</i> , New York, 2001.
Iskra-Janošić 1995	I. Iskra-Janošić: "Zaštitna arheološka istraživanja u 1994. godini", <i>GOMHV</i> 12, 1995, 125–131.
Iskra-Janošić 2001	I. Iskra-Janošić: <i>Urbanizacija Cibala i razvoj keramičarskih središta</i> , Vinkovci, 2001.
Nikolić-Đorđević 2000	S. Nikolić-Đorđević: "Antička keramika Singidunuma", <i>Singidunum</i> 2, Beograd, 2000, 11–245.
Nuber 1969–1970	H. U. Nuber: "Ein Siebgefäß aus Heddernheim", <i>RCRF</i> 11/12, 1969–1970, 70–75.
Ožanić 2004a	I. Ožanić: <i>Tipologija rimske keramike iz Vinkovaca</i> (neobjavljen magistarski rad / unpublished M.A. thesis), Sveučilište u Zagrebu / University of Zagreb, 2004.
Ožanić 2004b	I. Ožanić: <i>Olivijina cibalitanska kuharica: recepti rimskih autora prilagođeni 21. stoljeću</i> , Vinkovci, 2004.